

Strengthening Steel Girder Bridges with CFRP Plates

T. J. Wipf B. M. Phares
F. W. Klaiber Y. S. Lee

*Bridge Engineering Center
Iowa State University*

A.H. Al-Saidy

*Dept of Civil and Arch Engineering
Sultan Qaboos University*



Overview:

- Laboratory Investigation:
 - Evaluated the feasibility of using CFRP plates in strengthening steel-concrete composite beams
 - Tested ten small-scale, steel-concrete composite beams
 - » Two different arrangements of CFRP and two different levels of damage were investigated
- Field Investigation:
 - Used CFRP plates to strengthen an existing, structurally deficient steel girder bridge
 - Investigating short- and long-term effectiveness
 - Identified changes in structural behavior due to the addition of the strengthening system



Advantages of CFRP:

- Corrosion resistant
- Light weight
- High strength with a high fatigue life
- Can be installed with a minimal crew and common equipment



Nonlinear Analysis:

- Developed and validated an analytical model to investigate the impact of the following variables:
 - Area of the tension flange removed
 - CFRP plate ultimate strain
 - Area of CFRP added
 - CFRP stiffness
 - Compressive strength of deck slab concrete
 - Yield strength of the steel section being strengthened



Experimental Investigation:

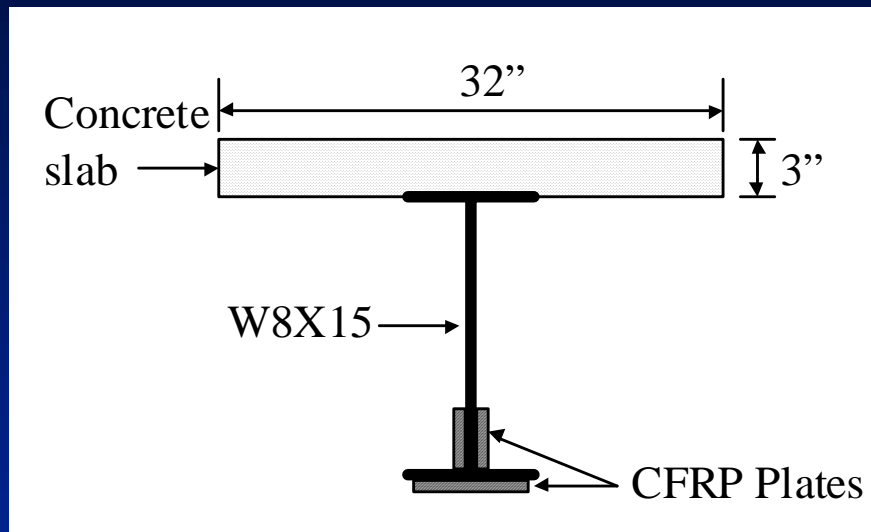

Undamaged beam

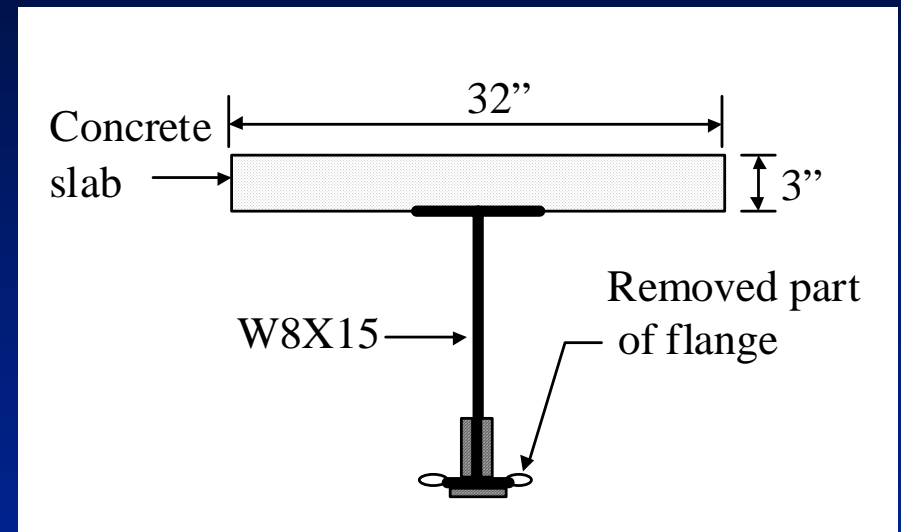

Damaged beam

Experimental Configuration

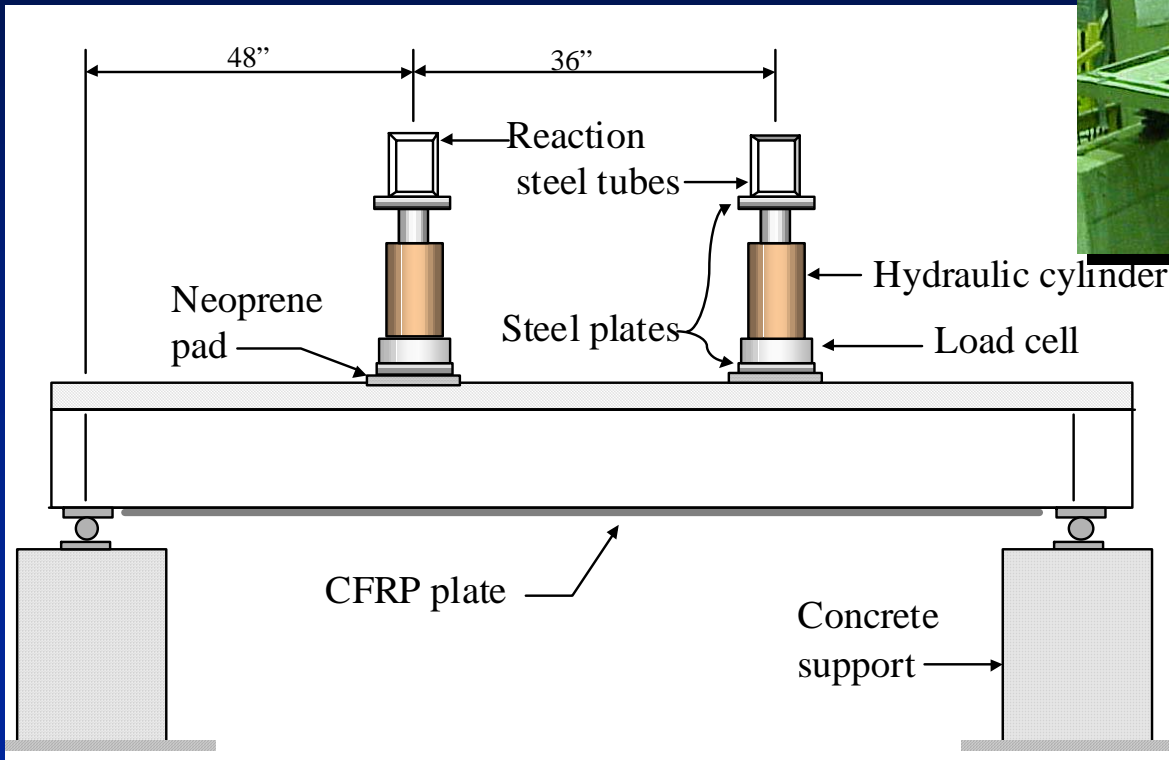
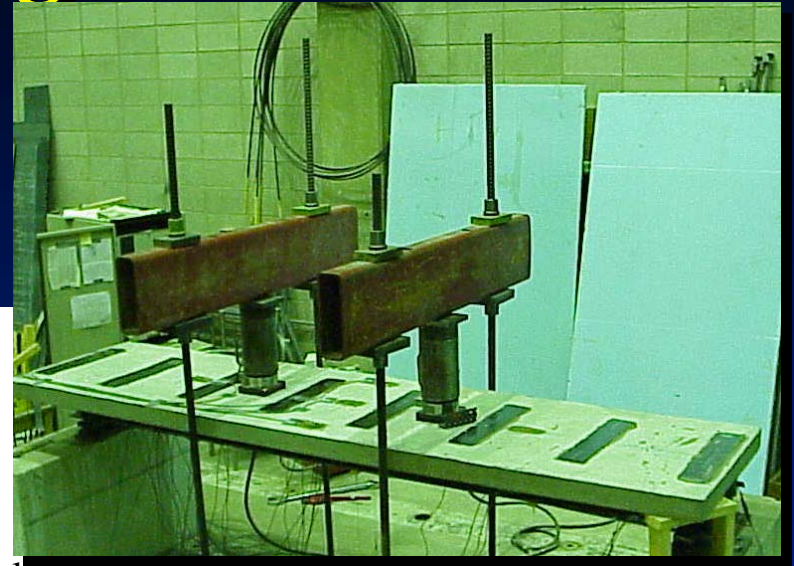

Failure Modes



Concrete crushing



CFRP plate rupture

Analytical Midspan Deflection

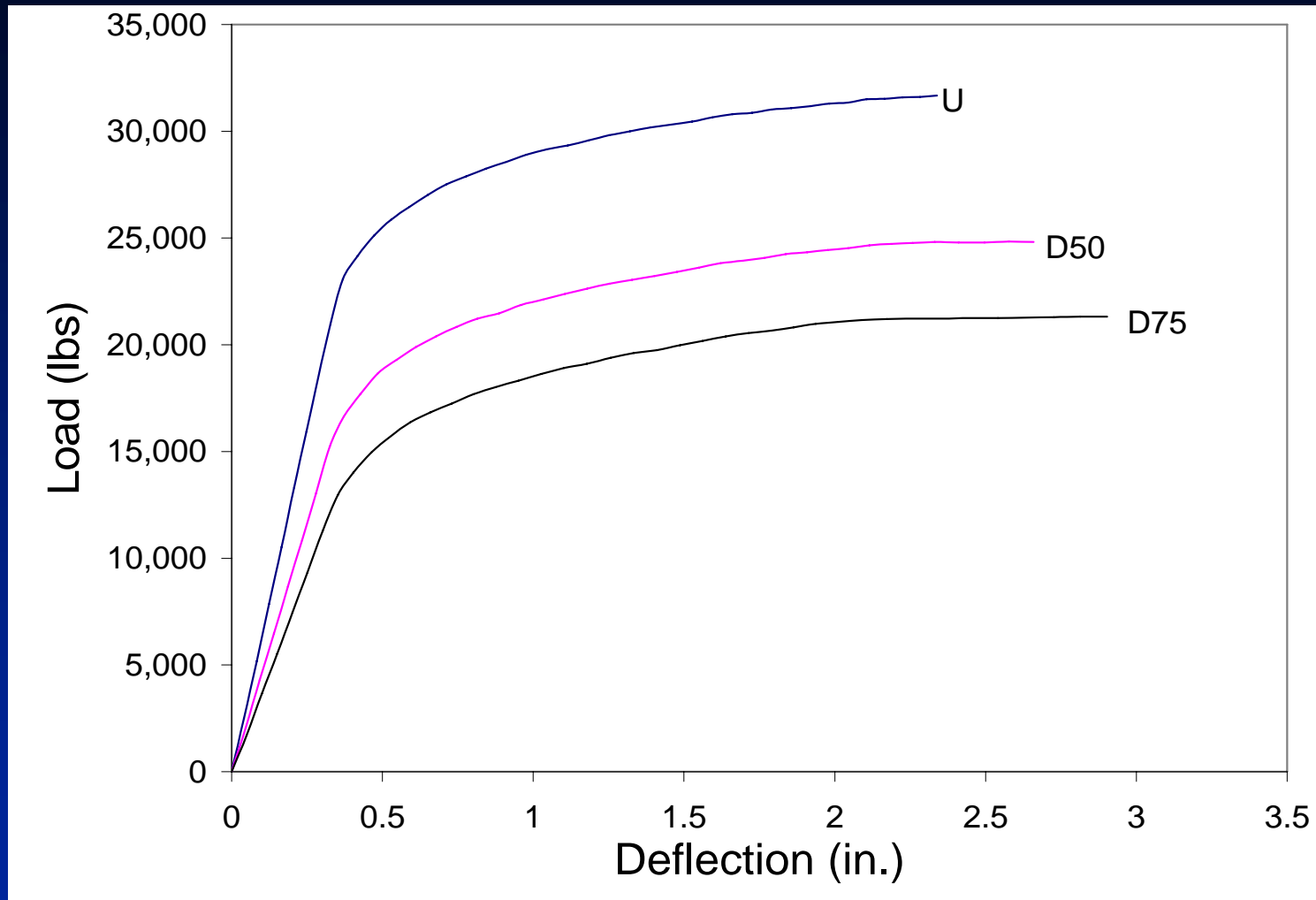

Impact of Repair Scheme 1

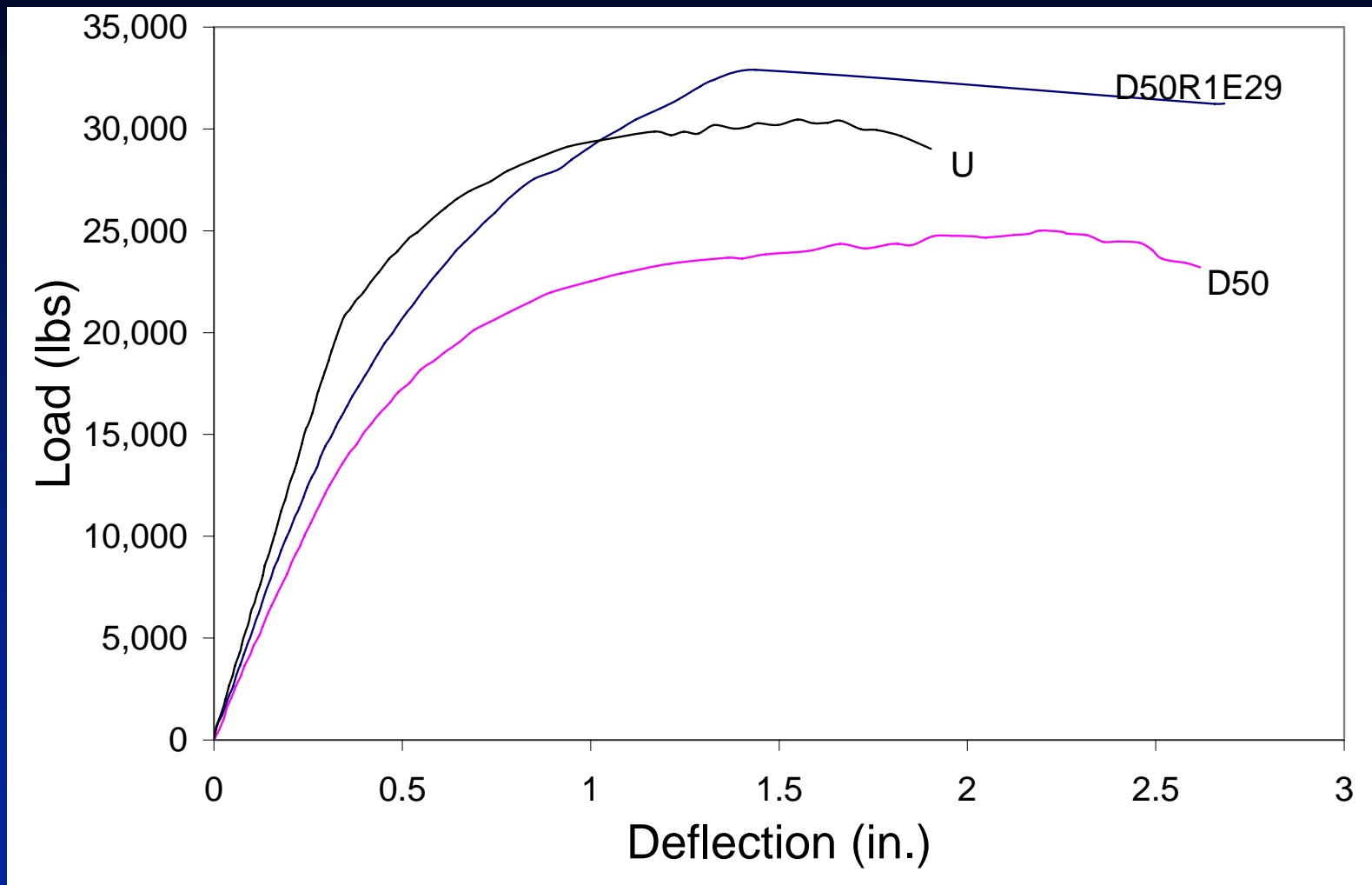

Impact of Repair Scheme 2

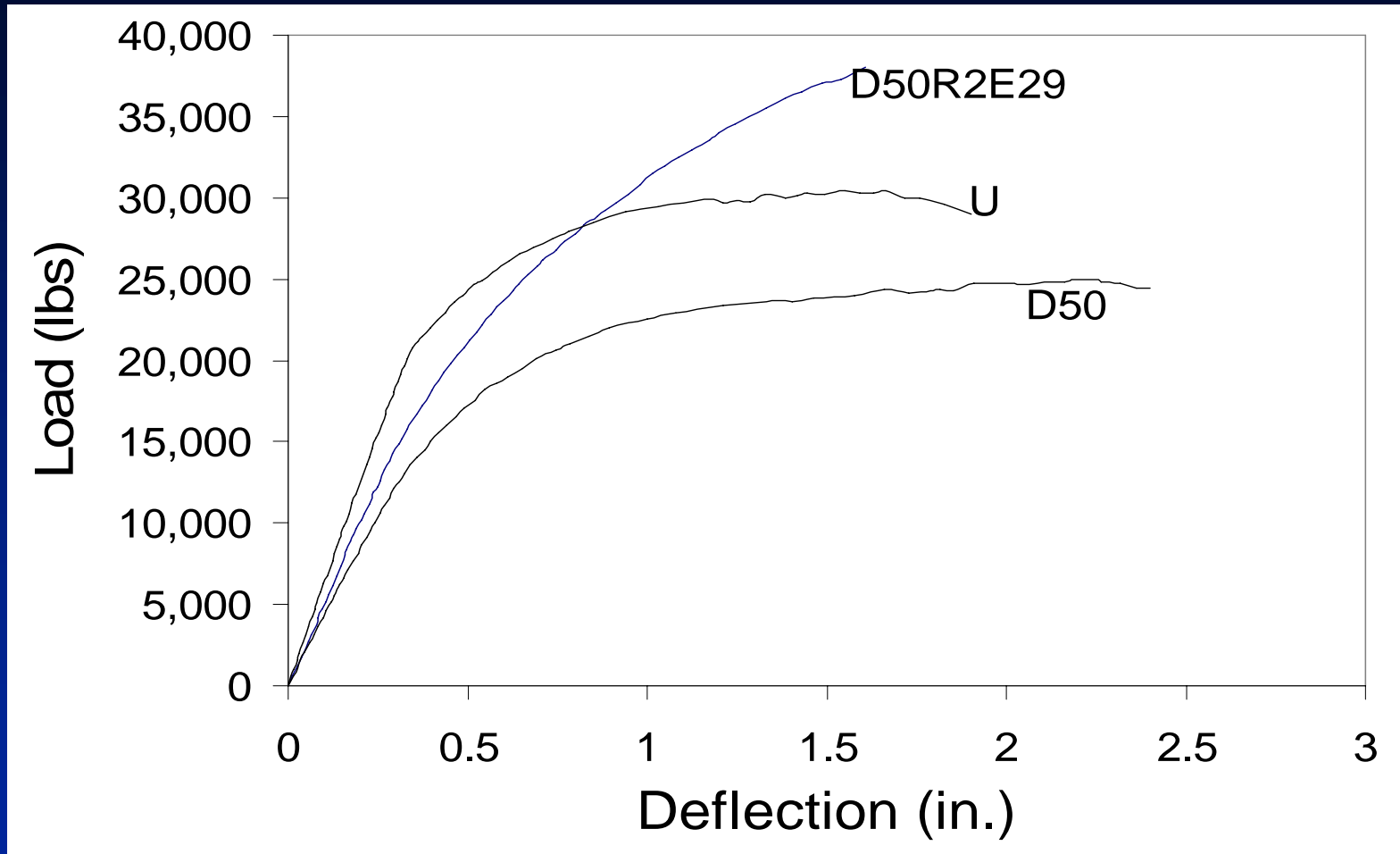

Description of Bridge:



- Located in Pottawattamie County, IA on State Highway IA 92
- Three-span continuous steel girder bridge
- Roadway width = 30 ft [two traffic lanes]
- Total length = 150 ft
 - Two 45.5 ft end spans and a 59 ft center span



Description of Bridge (continued)



- Constructed in 1938, the bridge was originally non-composite
- In 1967, it was widened by adding two composite exterior girders

Strengthening System

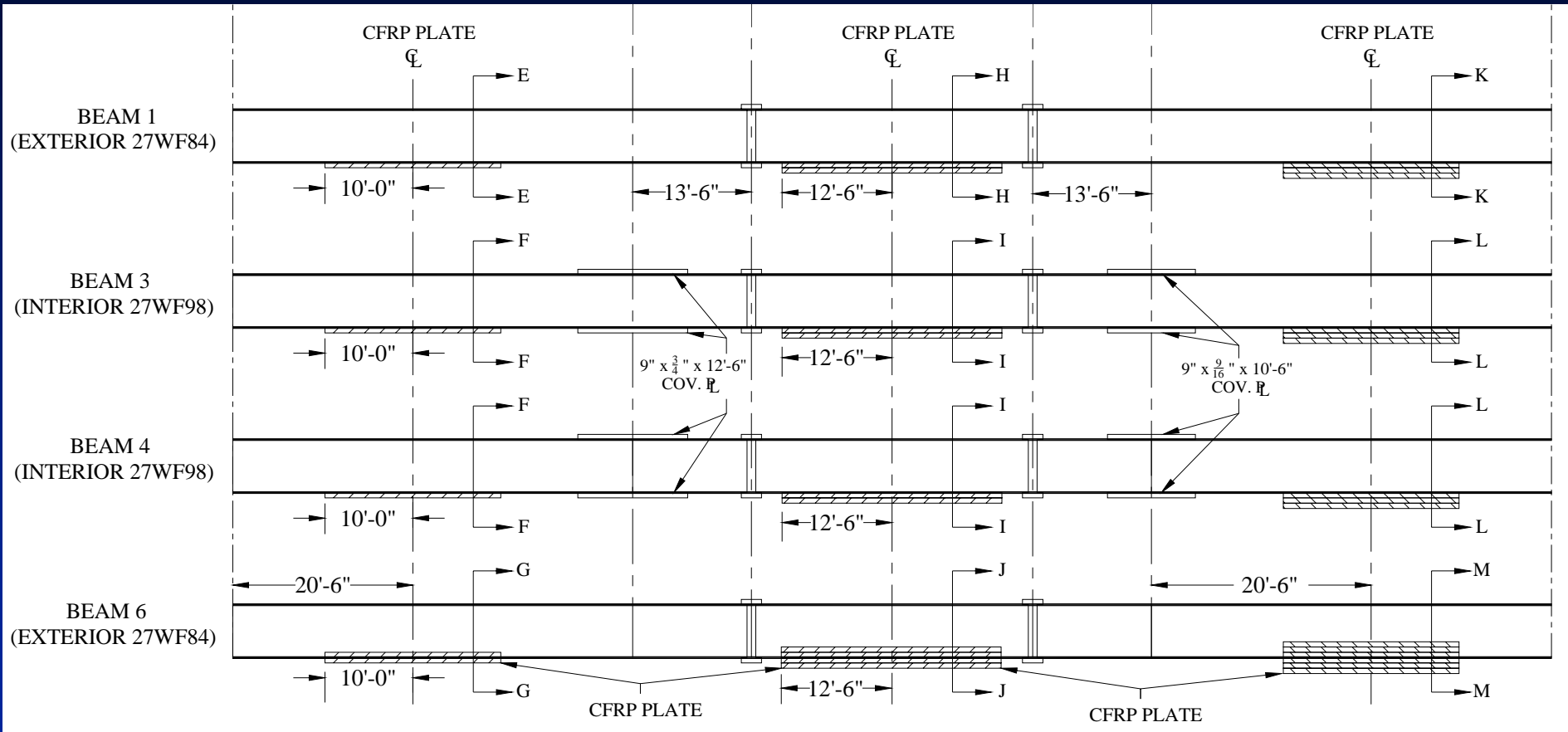



Cutting FRP Strips to the Desired Lengths



Removal of Paint from Beams - Stage 1



Removal of Paint from Beams - Stage 2



Cleaned Surface

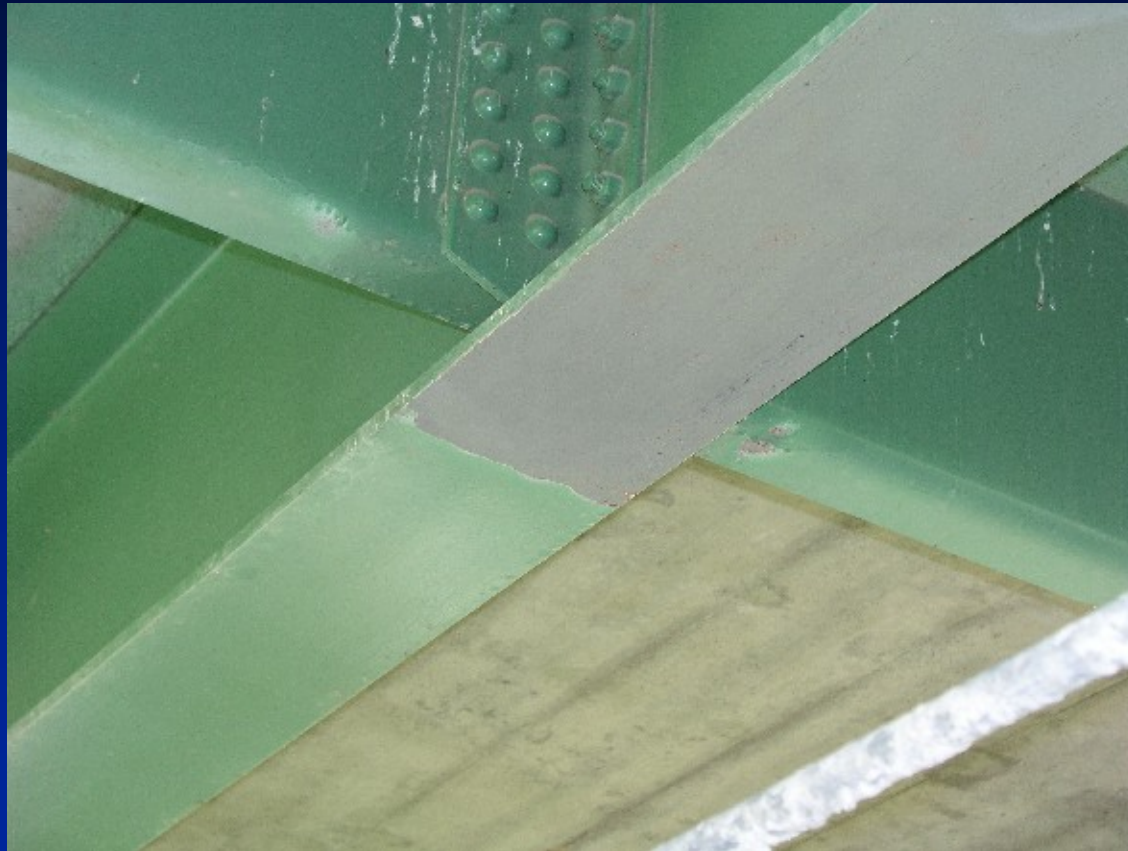

Cleaning of FRP Strips



Field Cleaning of FRP Strips



Final Cleaning of Beam Flanges





Installation of FRS Primer



Application of ECS 104 Structural Epoxy



Application of ECS 104 Structural Epoxy



Obtaining Desired Thickness of Epoxy



Application of Epoxy to Beam Flanges



Installation of FRP Strips to End Span Beams



Installation of FRP Strips to End Span Beams (continued)



Installation of FRP Strips to Center Span Beams



Installation of FRP Strips to Center Span Beams (continued)



Rolling of installed FRP Plates



Completed Installation of FRP Plates

One layer (West end span)



Three layers (East end span)



Load Testing



- Half of bridge was instrumented
- 3-axle truck used in three different load paths
- Data collected continuously as truck crossed the bridge
- Initial test and two follow-up tests completed to date

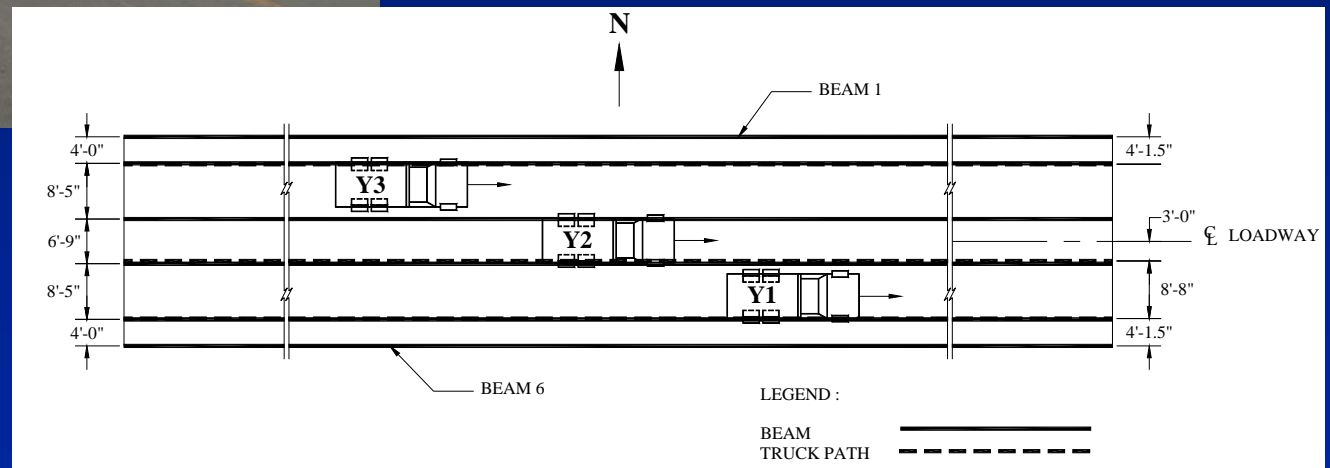

Live-load Flexural Response

- Elastic behavior
- Consistency in strains with time

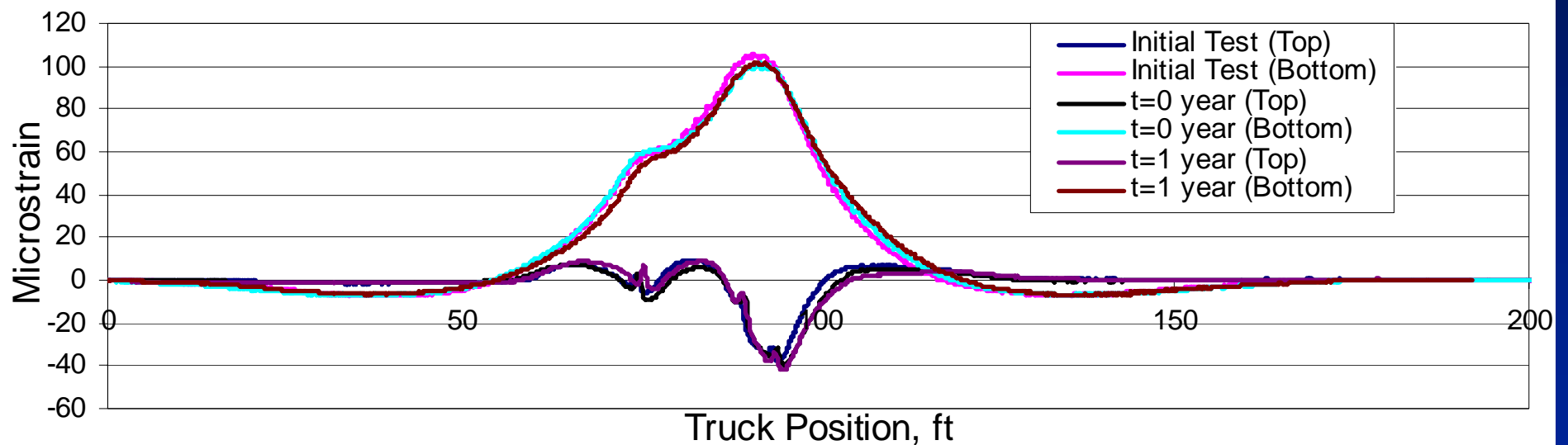

Bond Performance

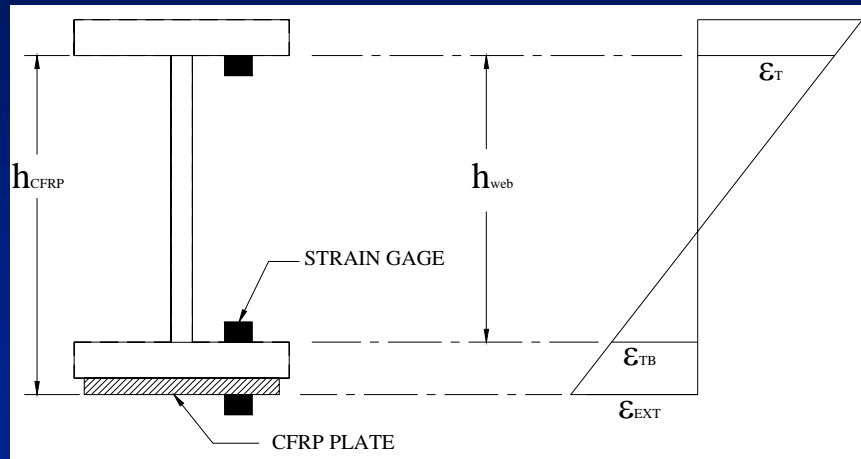

$$\epsilon_{EXT} = \frac{(\epsilon_T + \epsilon_{TB}) * h_{CFRP}}{h_{web}} - \epsilon_T$$

- Critical to have adequate bond for force transfer
- Gages installed on CFRP plate to investigate the bond performance
- Analytical model developed based on strain compatibility relation
- Extreme fiber strains were predicted and compared with experimental data

Bond Performance

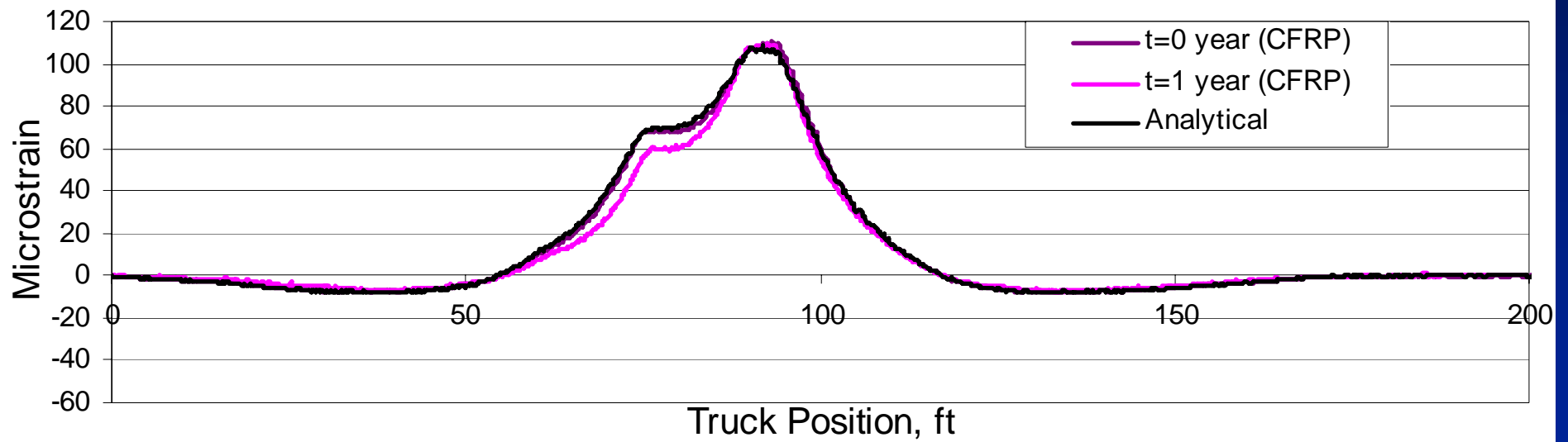

Concluding Remarks....

- Strength of damaged steel girders can be fully restored with the use of CFRP plates
- Stiffness of repaired steel girders is greater than that of the damaged girder, however not fully restored to that of the undamaged girder



Concluding Remarks [continued]...

- CFRP plates have minimal impact on changing the member's stiffness but can have a relatively large impact on changing member strength,if properly designed
- Bond performance after one-year of service was good



Concluding Remarks [continued]....

- The use of CFRP plates appears to be a viable strengthening alternative for steel girder bridges
- Handling and installation of CFRP plates was initially relatively labor intensive and required some training
A three-man crew was needed to install the system



Sponsorship:

Project was initiated by the
Iowa Department of Transportation

and was funded through the
*Federal Highway Administration's
Innovative Bridge Research and Construction
[IBRC] Program*

