

BENCH MARKS: No. 117 Sta. 740+73 Set R.R. Spike W. Side 36' Elm 150' Ct Elev. 633.32
 No. 118 Sta. 746+35 Set R.R. Spike W. Side Trans. 12' Ash 212' Ct Elev. 635.37
 No. 119 Sta. 756+60 Set R.R. Spike N. Side 18' Elm 147' Ct Elev. 640.31
 No. 119a Sta. 756+100, Set R.R. Spike N. Side 12' Elm 228' Ct Elev. 643.63

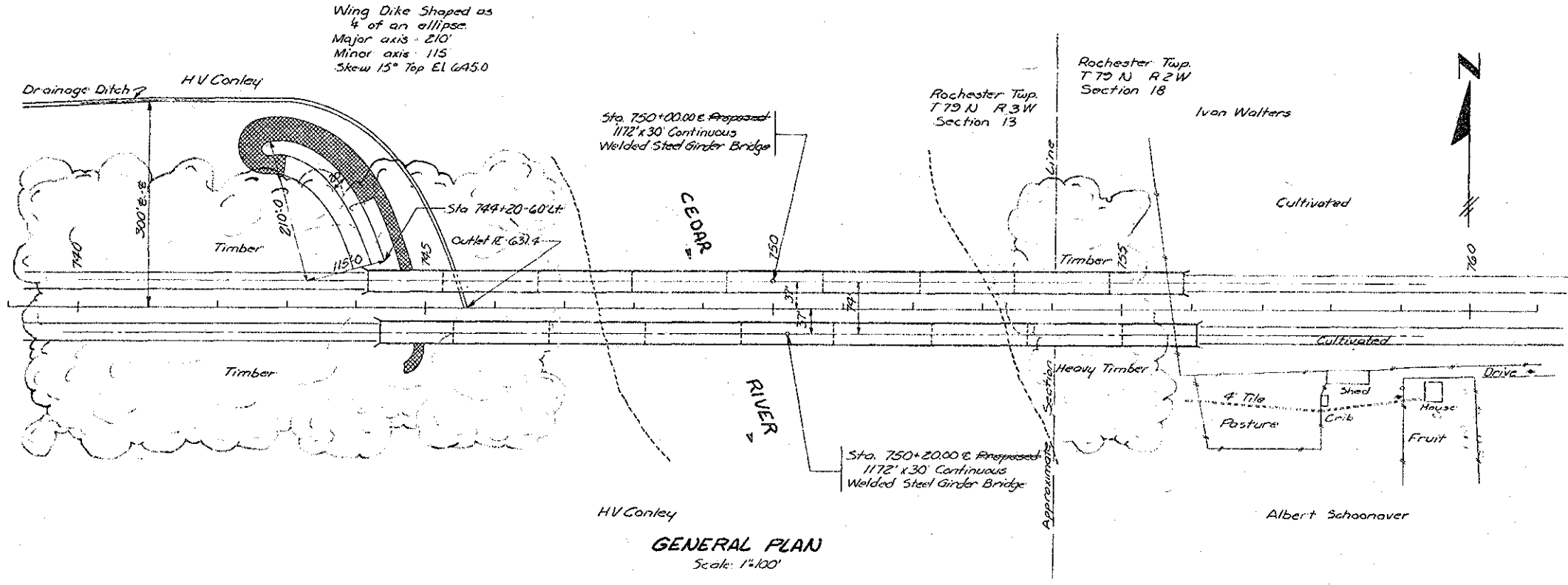
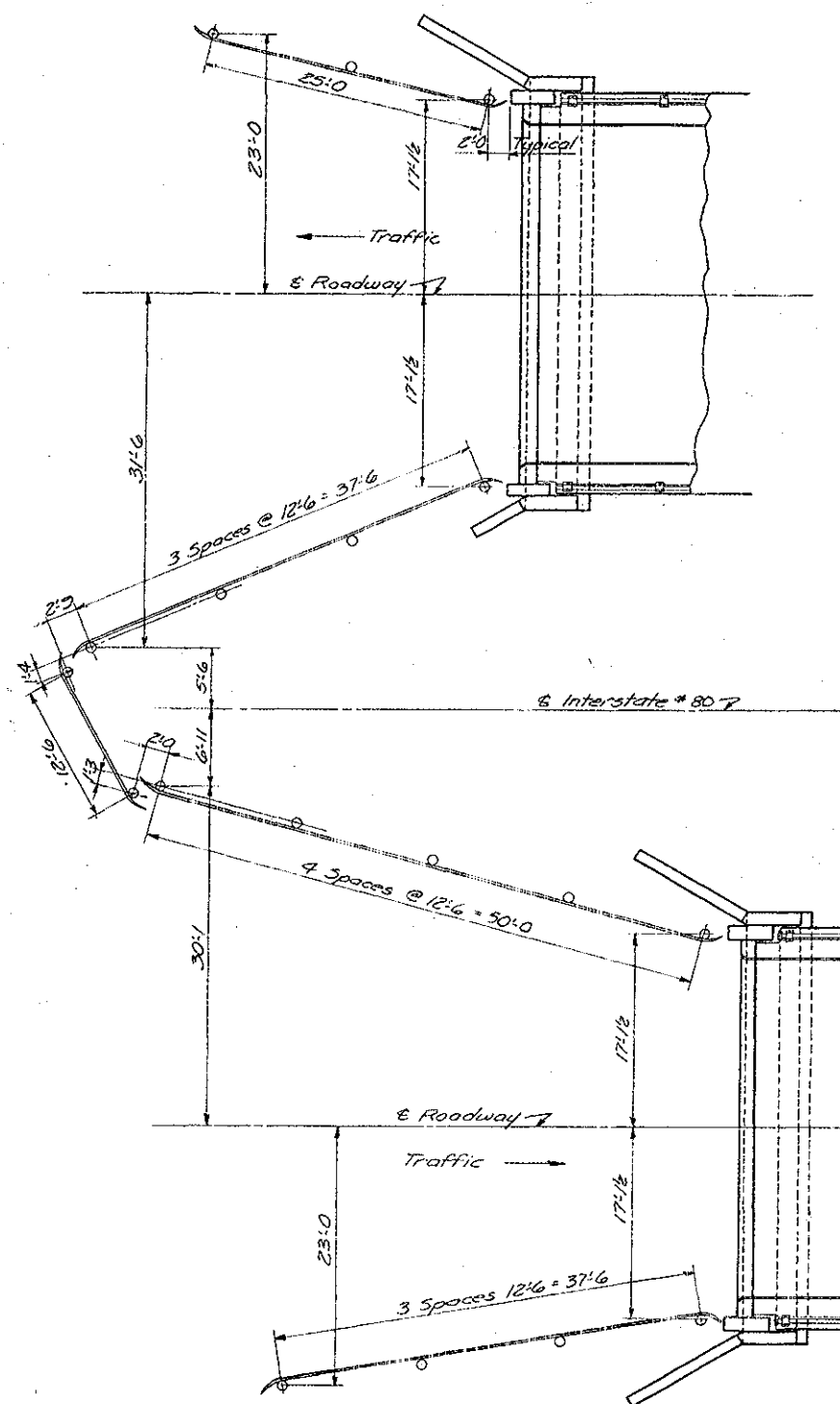

GENERAL PLAN
Scale: 1"=100'

GENERAL NOTES

These bridges are designed for H20-S16-44 loading plus 12 lbs. per sq. ft. of roadway for future wearing surface and for alternate loading designated BPR's PPM20-4 Section 4-C.
 The approach fills are not a part of this estimate but are to be in place before abutment piles are driven. The bridge contractor is to level off and shape the berms to the elevations shown.
 Formed steel beam guardrail and creosoted wood posts are to be furnished by others and are not a part of this estimate.

SPECIFICATIONS

Design AASHO, Series of 1957 and AASHO tentative specification series T(58).
 Construction: Standard Specifications of the Iowa State Highway Commission, series of 1956, plus current special provisions.

TOTAL ESTIMATED QUANTITIES				
Item	4 Abuts	16 Piers	2 Super str.	Total
Concrete	275.4	1341.25 1333.76	2209.2	3825.85 3818.01
Structural Steel			2,139,490	2,139,490 lbs.
Reinforcing Steel	21,698	211,542	682,568	915,808 lbs.
Steel Piles	27-0-75 13-0-25-2620 LF 14-0-20	180-0-50-2000 60-0-47-2820 30-0-37-149 LF 30-0-31-230		18,500 17,797.6 17,797.6
10BPA2	26-18-4 26-18-4	12-17-2 12-17-2		17,797.6 17,797.6
Aluminum Handrail		778.74 813		4620.2 LF 1096.74 1137
Excavation Class 20	318			1339 c.y. 1339
Excavation Class 21		1339		1339 c.y.
Excavation Class 22		134.0		134.0 c.y.

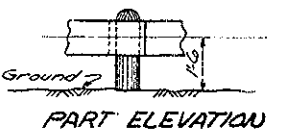

GUARD RAIL LAYOUT
Scale 3/8"=1'-0"

Note: Guard Rail by others

Constructed LOCATION

Cedar County
 T79N R3W T79N R2W
 Iowa Twp Rochester Twp
 Section 13 Section 18
 Interstate # 80 over
 Cedar River

Design for
TWIN 1172'-0" x 30' CONTINUOUS WELDED GIRDER BRIDGES

106'-6" End Spans
 Concrete Floor & Substructure
 7-137'-0" Interior Spans
 Aluminum Handrail

GENERAL PLAN

Station 750+00.00 North Lane
 Station 750+20.00 South Lane
 Project No. I-80-7(5)270

CEDAR COUNTY

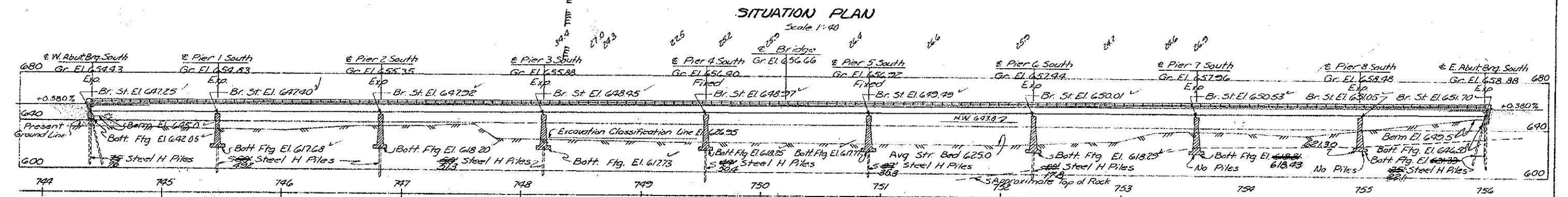
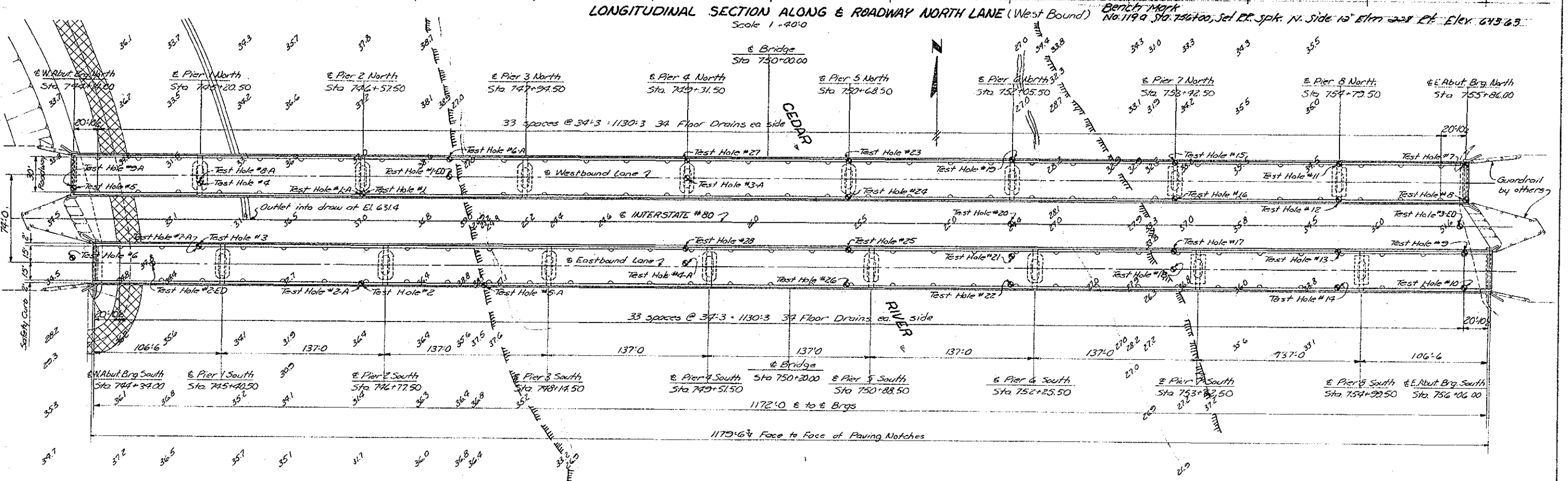
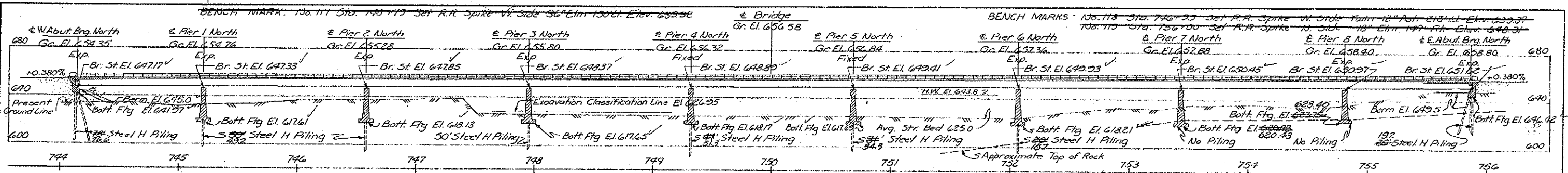

Design for
TWIN 1172'-0" x 30' CONTINUOUS WELDED GIRDER BRIDGES
 106'-6" End Spans Concrete Floor & Substructure
 7-137'-0" Interior Spans Aluminum Handrail

SITUATION PLAN
 Station 750+00 North Lane
 Station 750+20 South Lane
 Project No I-80-1051270
CEDAR COUNTY
 Iowa State Highway Commission
 April 1959
 Design 8859 Cedar County File No 20039

Note See Sheet 1 for General Notes, General Plan, Total Quantities and guardrail details
 See Sheets 3 & 4 for soundings

CONSTRUCTED AS SHOWN

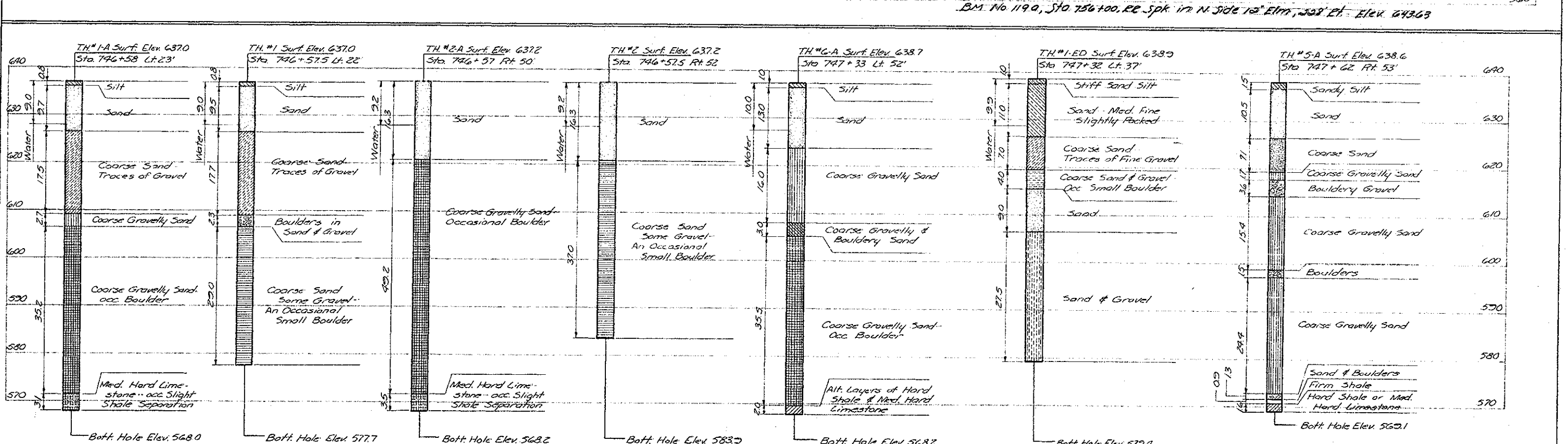
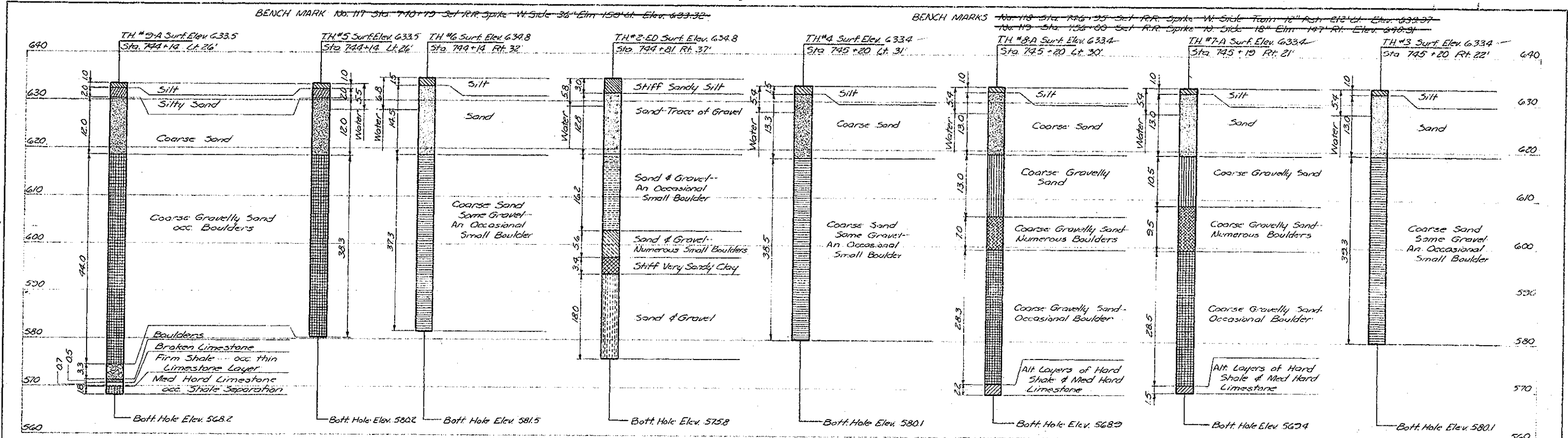

SOUNDING DATA
Scale 1"=10' 0"

CONSTRUCTED AS SHOWN

Design for
TWIN 112'-0" x 30' CONTINUOUS WELDED GIRDER BRIDGES
 10'-6" End Spans
 Concrete Floor & Substructures
 7'-13 1/2" Interior Spans
 Aluminum Handrail

BRIDGE SOUNDINGS

Station 750+00.00 North Lane
 Station 750+20.00 South Lane

CEDAR COUNTY
 Iowa State Highway Commission

April 1959
 Project No. I-80-7(5)270
 Sheet 3 of 13

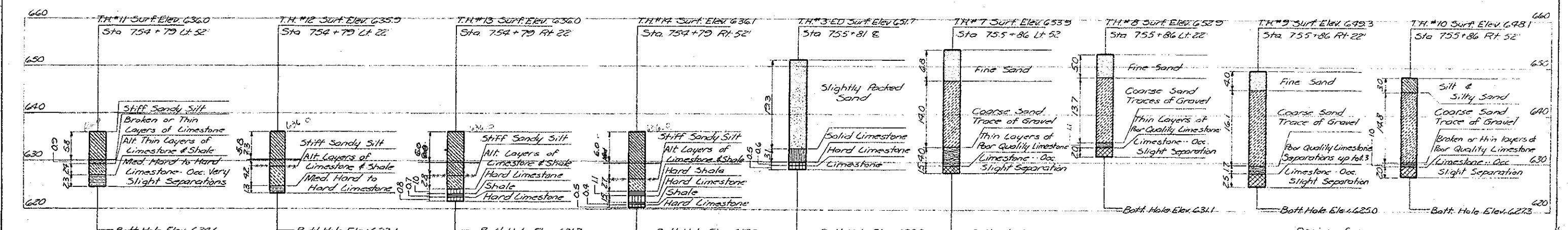
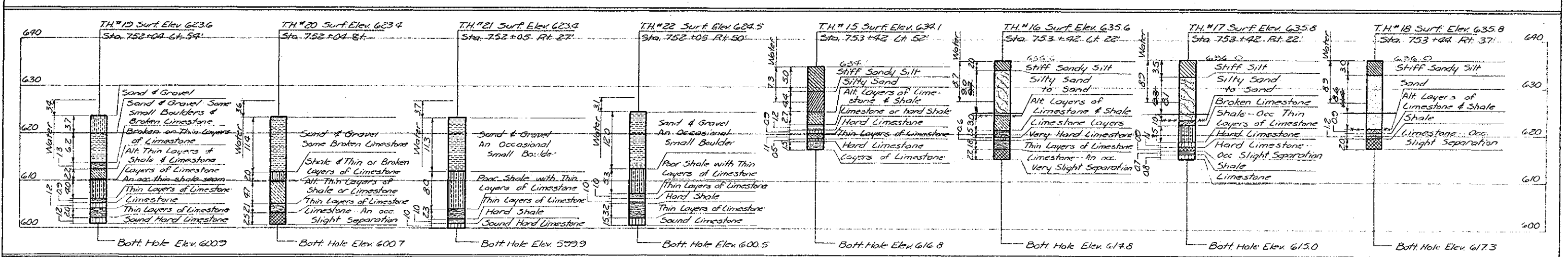
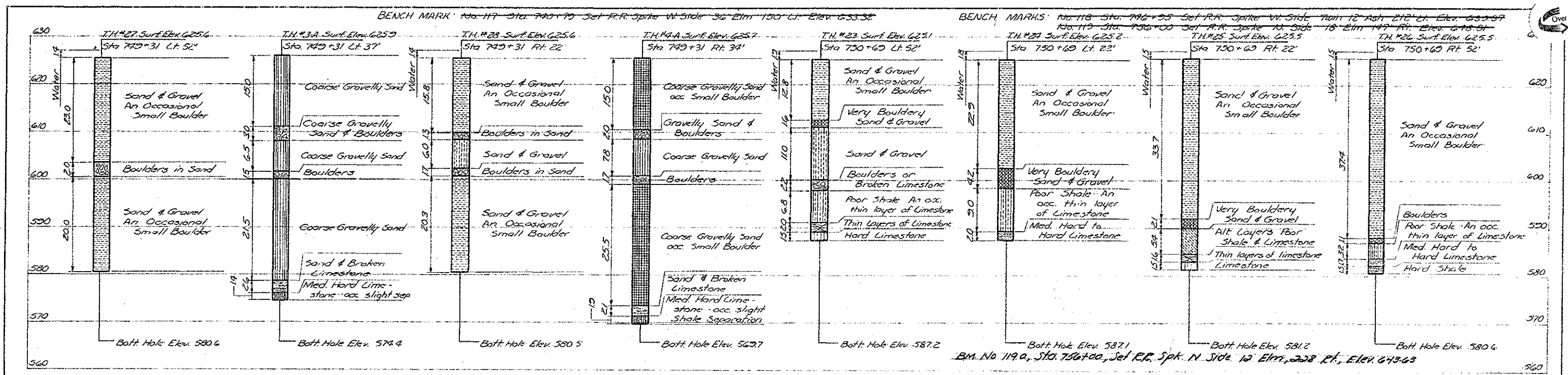

24.6
4.7
5.8
36.0

21.7
2.5
2.8
6.0
63.0

SOUNDING DATA
Scale 1"=10.0'

CONSTRUCTED AS SHOWN

Design for
TWIN 112'0" x 30' CONTINUOUS WELDED GIRDER BRIDGES
 106'-6" End Spans
 Concrete Floor & Substructure
 7-1370 Interior Spans
 Aluminum Handrail
BRIDGE SOUNDINGS

Station 750+0000 North Lane
 Station 750+2000 South Lane
 Cedar County
 Project No. I-80-750270

April 1952 Iowa State Highway Commission
 Sheet 4 of 13

Drawings 5857 Cedar County File No. 20039

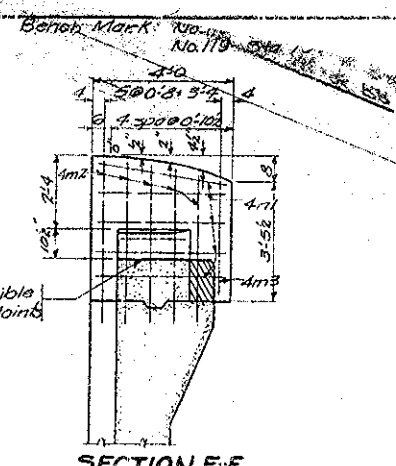
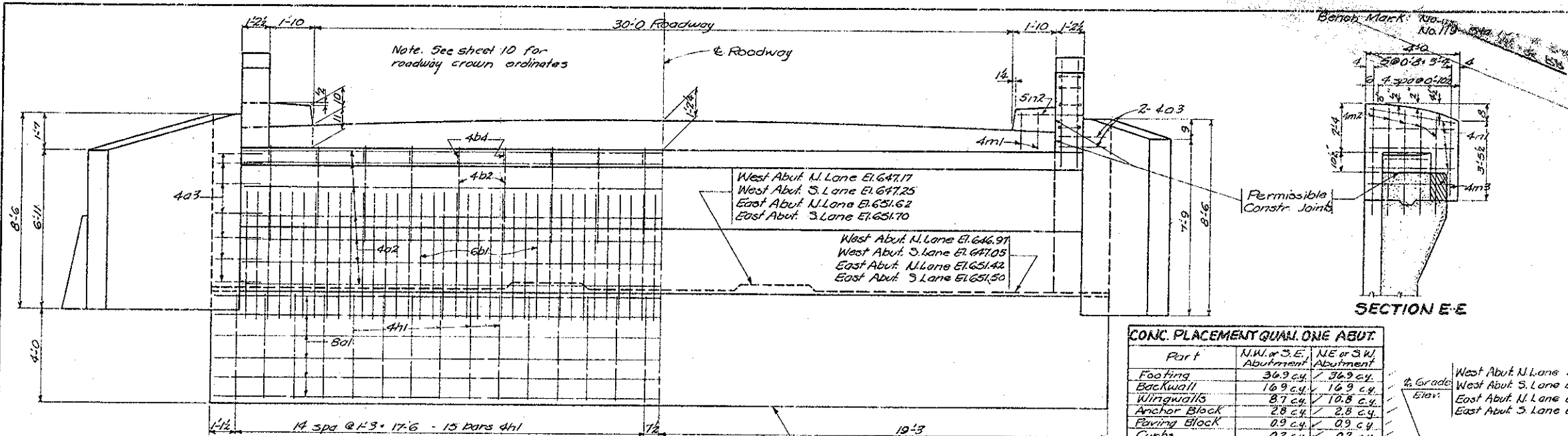

CONC. PLACEMENT QUANT. ONE ABUT.

Part	N.W. or S.E. Abutment	NE or SW Abutment
Footing	36.9 c.y.	36.9 c.y.
Backwall	16.9 c.y.	16.9 c.y.
Wingwalls	8.7 c.y.	10.8 c.y.
Anchor Block	2.8 c.y.	2.8 c.y.
Paving Block	0.9 c.y.	0.9 c.y.
Curbs	0.2 c.y.	0.2 c.y.
End Posts	1.4 c.y.	1.4 c.y.
Total	67.8 c.y.	69.9 c.y.

Note: Before placing temp. paving block bars 4b2 are to be bent down as shown and covered with tar paper. Anchor Block (See Sheet 12)

Location

Location	Quantity	Unit	Value
4a2 Backwall, Longitudinal	14	ft	14
4a3 Backwall, Vertical	24	ft	24
6b1 Backwall, Vertical, FF	10	ft	10
4b2 Backwall, Vertical, FF	10	ft	10
4b3 Backwall, Vertical, FF	10	ft	10
4b4 Backwall Tie	10	ft	10
6c1 Wing, Horizontal, FF	30	ft	30
6c3 Long Wing Horiz. FF	50	ft	50
6c2 Long Wing Horiz. FF	18	ft	18
6c4 Short Wing Horiz. FF	18	ft	18

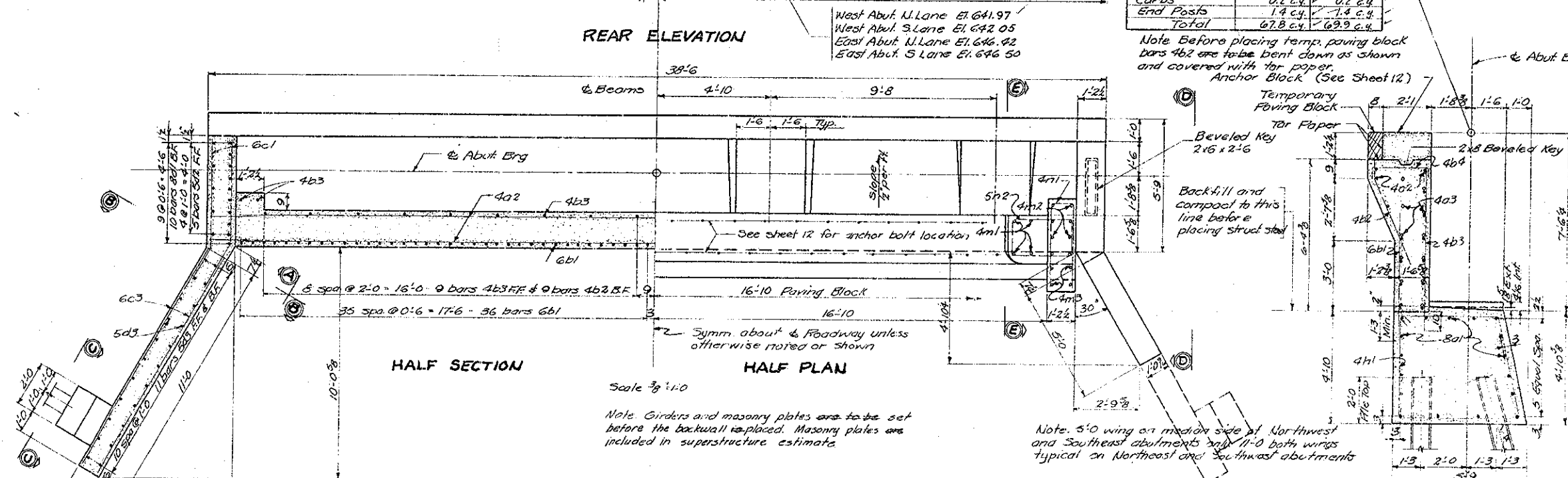

8.1 Wing, Vertical, FF	20	9'2"	189	189
5d2 Wing, Vertical, FF	10	8'6"	89	89
5d3 Long Wing Vert. FF	44	Varies		338
5d2 Long Wing vert. FF	22	Varies	169	
5d3 Short Wing Vert. FF	10	Varies	81	
5f1 Pile Cap, Vertical	4	3'9"		16
5f2 Pile Cap, Vertical	2	3'9"		8
5f2 Pile Cap, Hoops	10	Varies		85
5f2 Pile Cap, Hoops	5	Varies		43
4h1 Footing Hoops	30	19'8"	394	394
4m1 Curb, Vertical	8	1'6"	8	8
4m2 End Post, Vertical	20	4'9"	63	63
4m3 End Post, Vertical	4	3'2"	8	8
4n1 End Post, Horizontal	10	8'4"	56	56
5r2 Curb Hoops	2	9'6"	20	20
4p1 Anchor Block, Longit.	4	33'4"	89	89
4p2 Anchor Block Hoops	24	3'8"	39	39
Totals			5,274	5,575

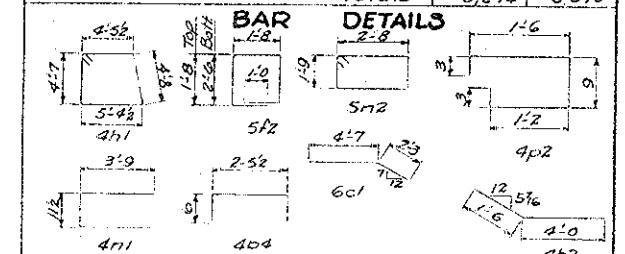

ABUTMENT NOTES

All exposed corners of 90° or sharper shall be filleted with a 3/4" dressed and beveled strip. Minimum distance from face of concrete to 2" of near reinforcing bar to be 2" unless otherwise noted or shown.

All piling is to be driven to refusal on rock, if practicable but to at least a 37 ton bearing value.

SPECIFICATIONS

Design A.A.S.H.O., Series of 1957.
Construction SPS Specifications, Iowa State Highway Commission Series of 1956, plus current special provisions.

TOTAL ESTIMATED QUANT. - 4 ABUTMENTS

Concrete	275.4 c.y.
Reinforcing Steel	21,698 lbs
Furnish 10BP42 Steel Piling	26,500 LF
Drive 10BP42 Steel Piling: 27 @ 15', 13 @ 25', 14 @ 20'	26,500 LF
Class 30 Excavation: 2 @ 81 and 2 @ 76	318 c.y.

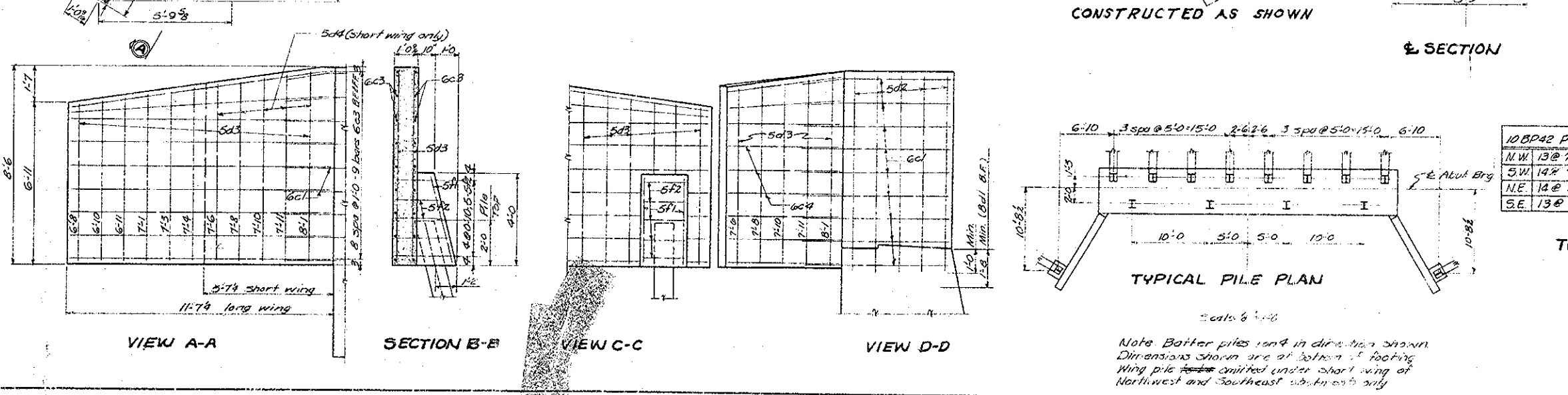

Design For
TWIN 1172' x 30' CONTINUOUS WELDED GIRDER BRIDGES

12'-6" End Spans 7'-13'7" Interior Spans
Concrete Floor and Substructure Aluminum Rail

ABUTMENT DETAILS

Sta 750+20.00 North Lane
Sta 720+20.00 South Lane

CEDAR COUNTY

IOWA STATE HIGHWAY COMMISSION

April 1959

Design 8859 Cedar County Sheet 5 of 13

B.M. No. 1190, Sta. 756+00, R.R. Spk. in N. Side 12 Elm, 228 Lt., Elev. 643.63



PIER DIMENSIONS						
PIER NUMBER						
	1N	3N	5N	7N	7S	8N
H	29'-6"	30'-6"	31'-6"	29'-6"	31'-6"	27'-0"
F	20'-3"	21'-3"	22'-3"	20'-9"	22'-9"	-
E	14'-6"	14'-6"	14'-6"	14'-6"	14'-6"	-
S	4'-4 1/2"	4'-4 1/2"	4'-4 1/2"	4'-4 1/2"	4'-4 1/2"	-
M	3'-9"	3'-9"	3'-9"	3'-9"	3'-9"	-
S	23'-6"	23'-6"	23'-6"	21'-6"	23'-6"	-
Z	3'-0"	3'-0"	3'-0"	3'-6"	2'-6"	-

PIER ELEVATIONS			
Pier No	Elev. A	Elev. B	Elev. C
2N	655.28	647.85	618.13
3N	655.80	648.37	617.65
4N	656.32	648.89	618.17
5N	656.84	649.41	617.69
6N	657.36	649.93	618.21
7N	657.88	650.45	620.73
8N	658.40	650.97	623.25
1S	654.83	647.40	617.68
2S	655.35	647.92	618.20
3S	655.88	648.45	617.73
4S	656.40	648.97	618.25
5S	656.92	649.49	617.77
6S	657.44	650.01	618.29
7S	657.96	650.53	618.81
8S	658.48	651.05	621.33

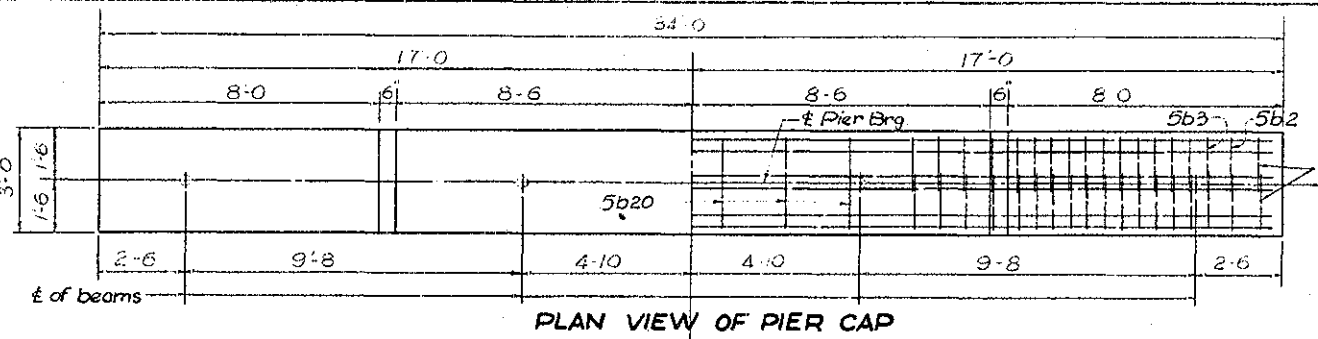

PLAN VIEW OF PIER CAP

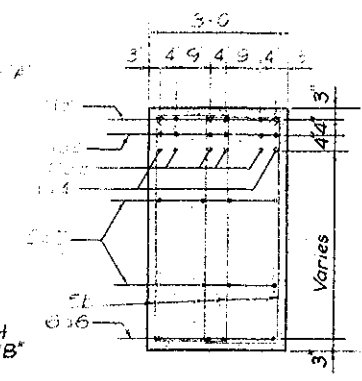

SECTION A-A
Scale 1/2" = 1'-0"

* Includes 1/8" for point & canvas

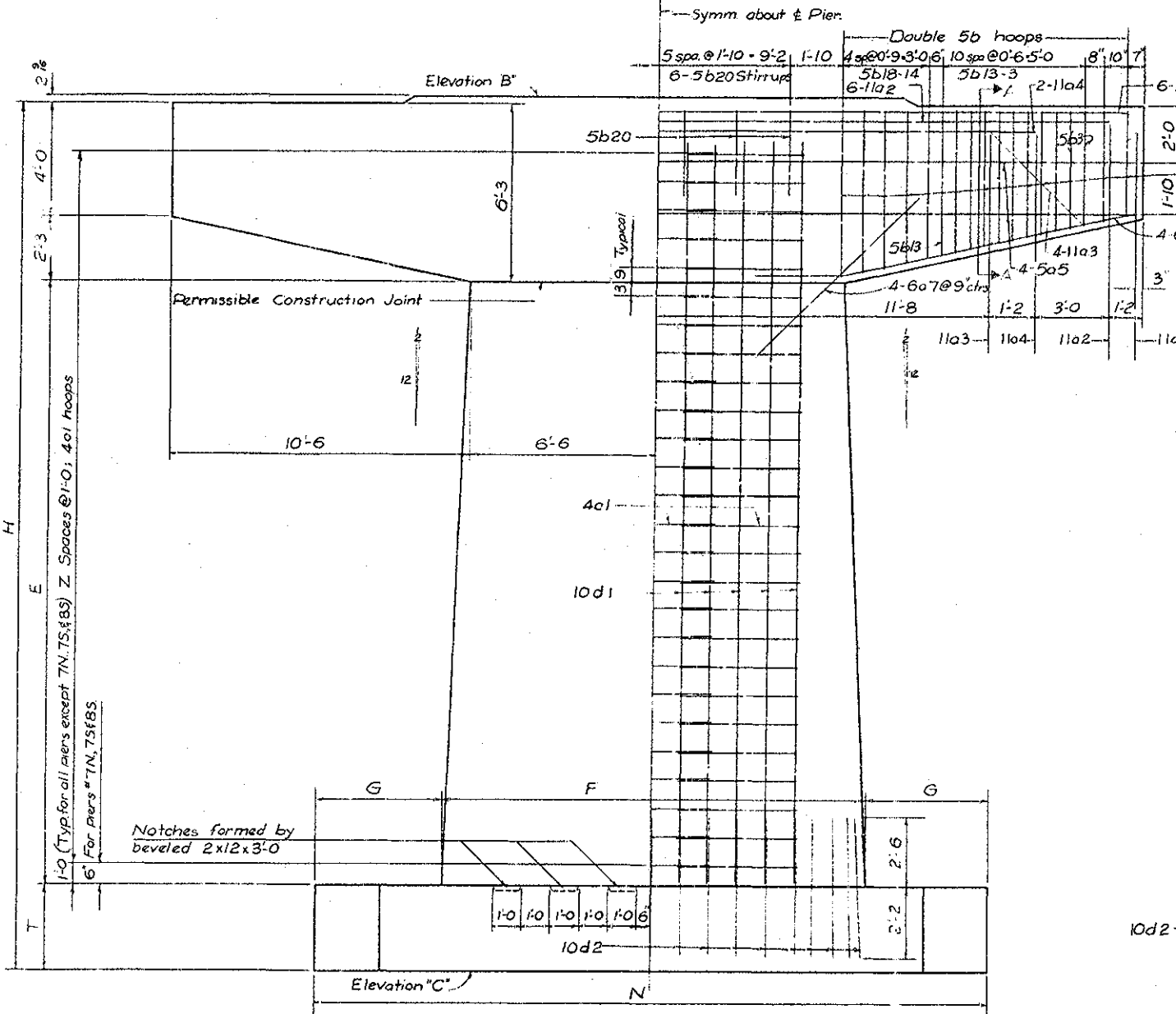

PIER ELEVATION
Scale 3/8" = 1'-0"

See sheet # 7 for Quantities, Footing and Piling Details, and Reinforcing List.

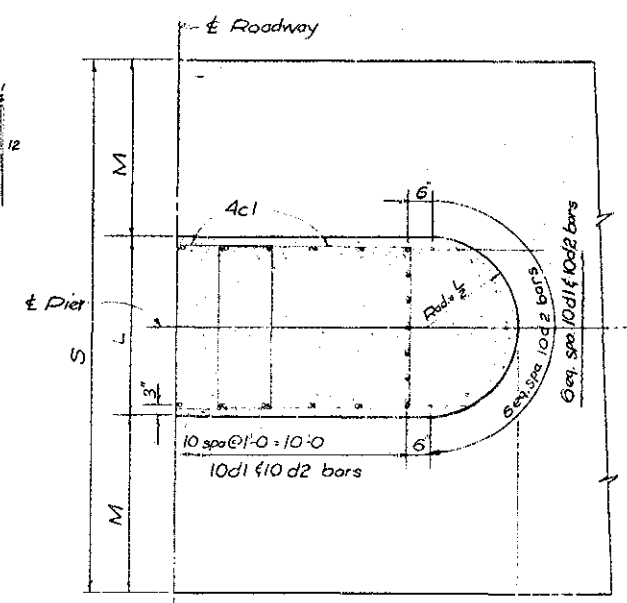

PART PLAN VIEW OF FOOTING
Scale 1/2" = 1'-0"

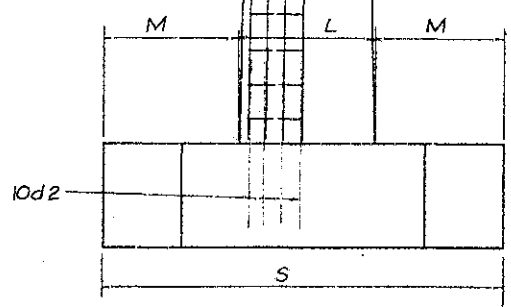

END VIEW

CONSTRUCTED AS SHOWN

PIER NOTES:
 All exposed corners of 90° or sharper are to be filleted with a 3" dressed and beveled strip.
 All piling is to be driven to refusal on rock if practicable but to at least 37 ton bearing value.
 Pier Nos 7N, 7S, 8N & 8S are founded on rock. These footings shall extend at least 5' into solid rock and the rock excavation shall be to neat lines of masonry.
 Clear distance from face of concrete to near reinforcing bars is to be 1 1/2" unless otherwise noted or shown.

SPECIFICATIONS:
 Design: A.A.S.H.O. Series of 1957.
 Construction: Iowa State Highway Commission Standard Specifications, Series of 1956, plus current special provisions.

Design For
TWIN 112'-0" x 30' CONTINUOUS WELDED GIRDER BRIDGES
 106'-6" End Spans 7'-137'-0" Interior Spans
 Concrete Floor & Substructure Aluminum Rail
PIER DETAILS
 Station 750+00.00 North Lane Project No I-80-7(5)270
 750+20.00 South Lane
CEDAR COUNTY
 Iowa State Highway Commission
 April 1959 Sheet 6 of 13
 Design 8859 Cedar County File No 20039

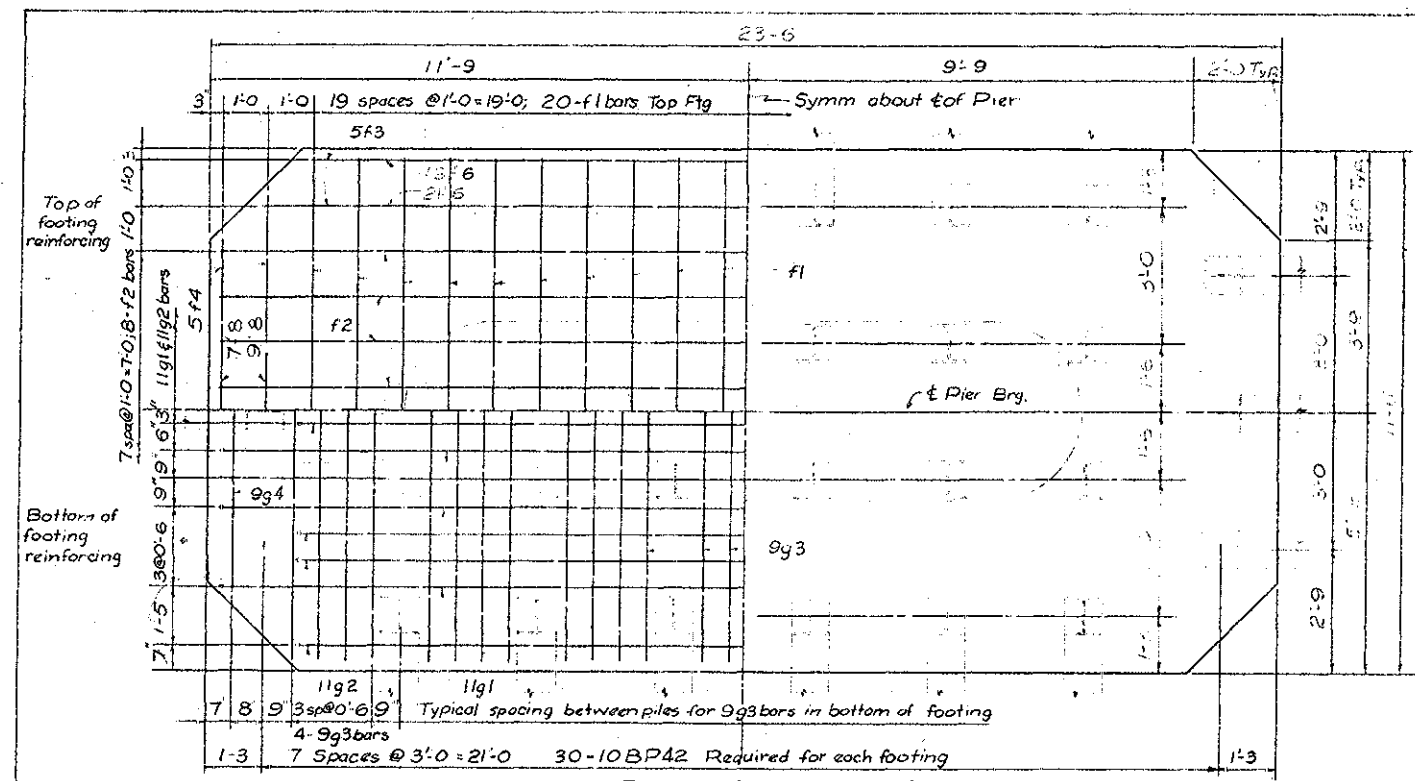

PLAN OF FOOTING (Typical for footings founded on piles.)
Scale 1/2"=1'-0"

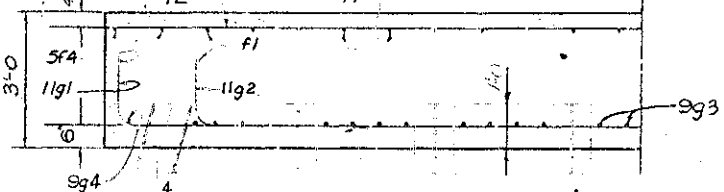

HALF SECTION AT PIER BEARING (Dowels and Column not shown)
Scale 1/2"=1'-0"

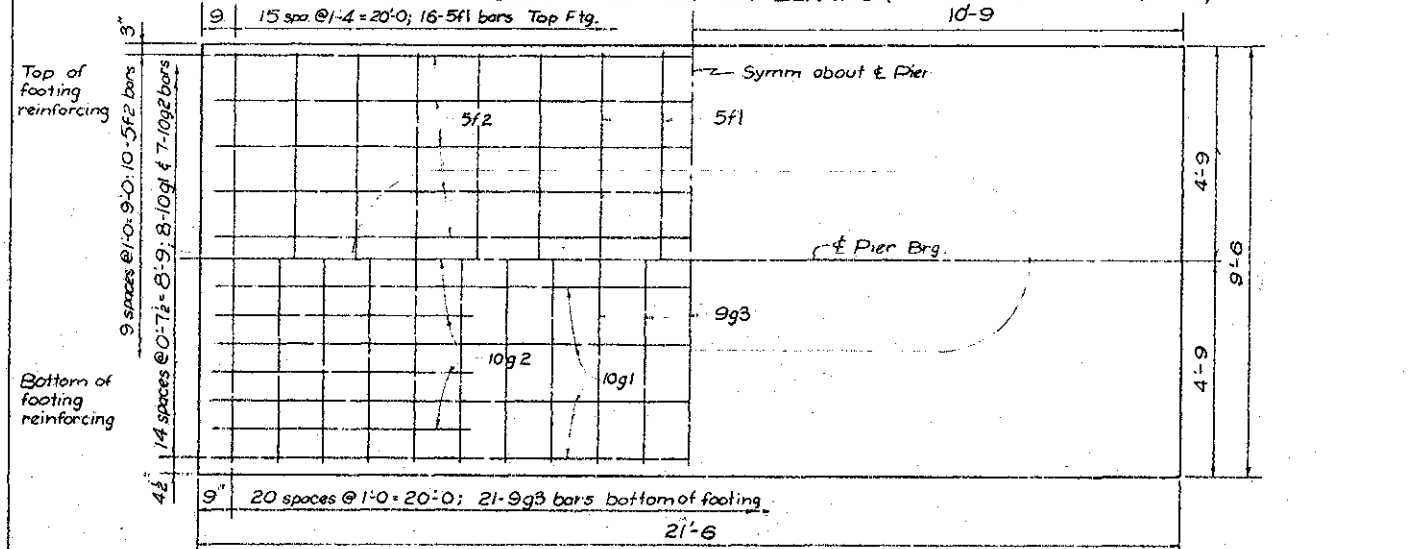

PLAN OF FOOTING (Typical for footings 7N, 7S, 8N, & 8S founded on rock.)
Scale 1/2"=1'-0"

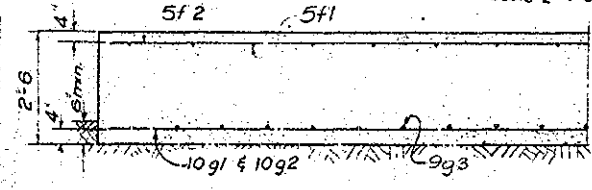

HALF SECTION AT PIER BEARING (Dowels and Column not shown)
Scale 1/2"=1'-0"

Note: Dimensions shown are at bottom of footing. Batter perimeter piles 1/4 in the direction shown

See sheet #6 for Pier Column & cap details & notes.

REINFORCING BAR LIST FOR PIERS

Item	Quantity	Weight (lbs)	Item	Quantity	Weight (lbs)
Cap Hoops	4	13.72	Column Hoops	4	13.72
Cap Stirrups	5	16.48	Column Vertical	4	13.72
Column Hoops	4	13.72	Column Dovers Vert	4	13.72
Column Vertical	4	13.72	Footing Top Transv	8	36.9
Column Dovers Vert	4	13.72	Footing Top Longit	8	49.5
Footing Top Transv	8	36.9	Footing Top Longit	8	49.5
Footing Top Longit	8	49.5	Footing Bott Longit	11	50.3
Footing Bott Longit	11	50.3	Footing Bott Transv	9	41.2
Footing Bott Transv	9	41.2	Footing Bott Transv	9	41.2
Total	13,721	54,884 lbs	Total	13,476	53,904 lbs

BENT BAR DETAILS

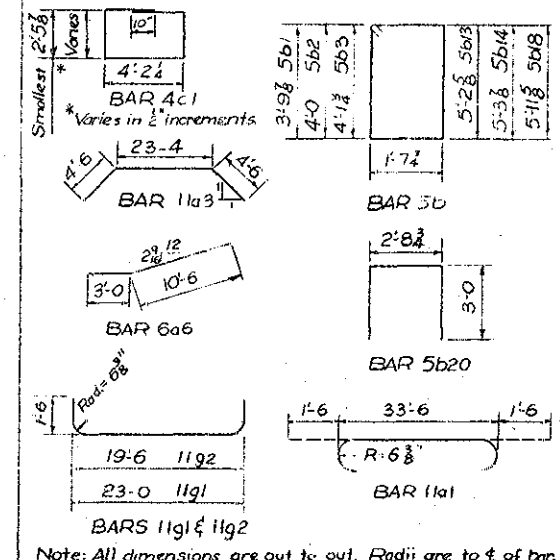

Note: All dimensions are out to out. Radii are to center of bar.

*Note: Bars 10g1 & 10g2 are straight

PIER CONCRETE QUANTITIES

Pier	Concrete (cy)	Reinforcing (lbs)	Steel Piling (lin ft)	10 BP 42 (lin ft)
1	35	13,721	150	150
2	33	13,476	140	140
3	35	13,721	150	150
4	33	13,476	140	140
5	12,067	24,134	1,370	1,370
6	12,409	24,818	1,410	1,410
7	11,627	23,254	1,330	1,330

TOTAL ESTIMATED PIER QUANTITIES

Material	Quantity	Weight/Volume	Total
Concrete	116,000	145 lb/cy	16,820,000
Reinforcing	116,000	1.5 lb/lin ft	174,000,000
Steel Piling	116,000	150 lb/lin ft	17,400,000
10 BP 42	116,000	150 lb/lin ft	17,400,000
Class 20 Excavation	451	100 lb/cy	45,100
Class 21 Excavation	492	100 lb/cy	49,200
Class 22 Excavation	351	100 lb/cy	35,100

CONSTRUCTED AS SHOWN STEEL PILING (10 BP 42)

Pier	Length (LF)	Weight (lbs)
1N	30 @ 50	1474.8
1S	30 @ 50	1474.7
2N	30 @ 50	1476.4
2S	30 @ 50	1476.5
3N	30 @ 50	1501.5
3S	30 @ 50	1539.0
4N	30 @ 47	1541.0
4S	30 @ 47	1512.1
5N	30 @ 31	1030.9
5S	30 @ 37	1055.9
6N	30 @ 20	596.0
6S	30 @ 20	596.0
Total	15,066 LF	15,188.5 LF

Design For TWIN 117'-0" x 30" CONTINUOUS WELDED GIRDER BRIDGES
106'-6" End Spans 7-137'-0" Interior Spans
Concrete Floor & Substructure Aluminum Rail

PIER DETAILS
Station 750+00.00 North Lane Project No I-80-7(5) 270
750+20.00 South Lane
CEDAR COUNTY
Iowa State Highway Commission
April 1959 Design 8859 Cedar County File No 20039 Sheet 7 of 13

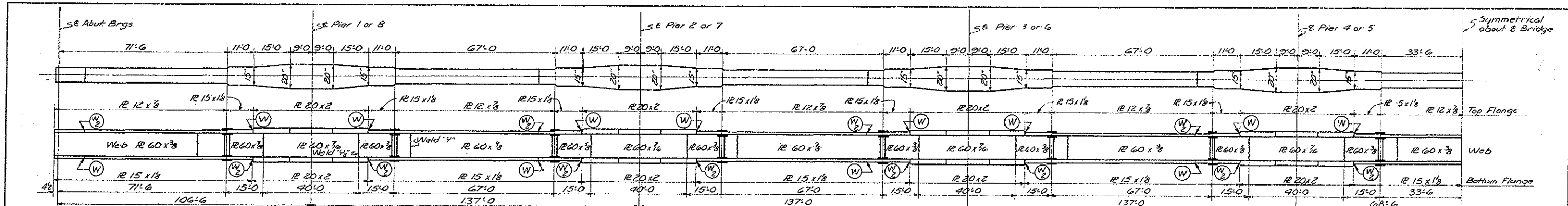

EXTERIOR GIRDER

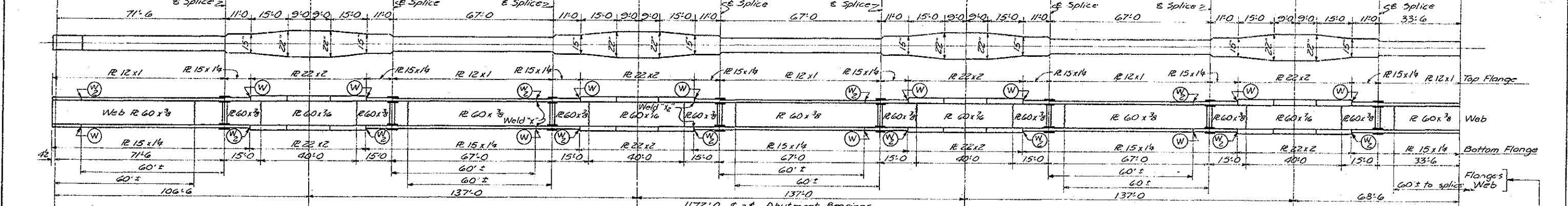

INTERIOR GIRDER

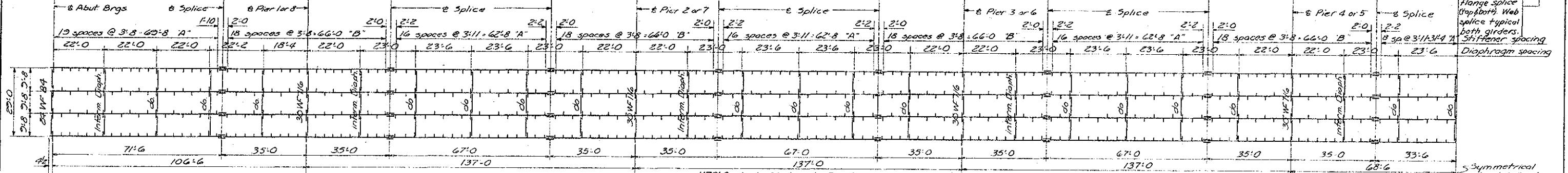

STRUCTURAL STEEL LAYOUT

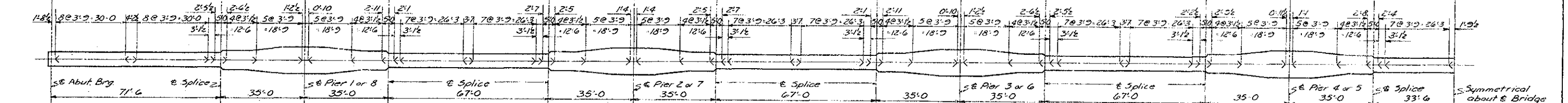

SHEAR LUG SPACING - EXT. & INT. GIRDER

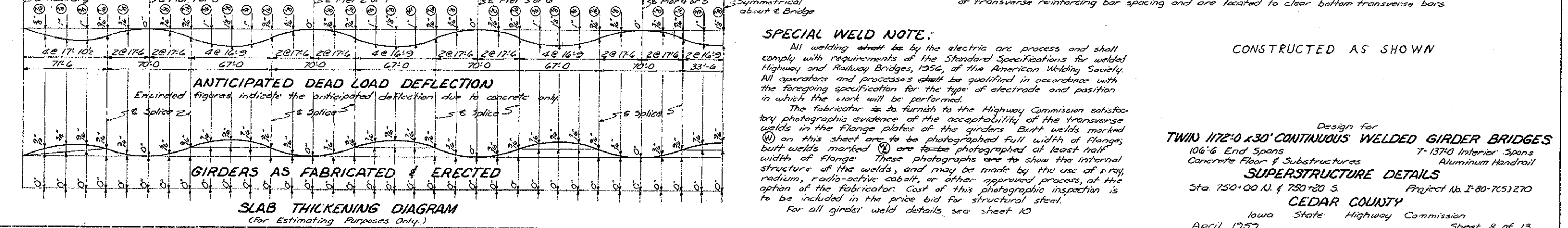

SPECIAL WELD NOTE:
 All welding shall be by the electric arc process and shall comply with requirements of the Standard Specifications for welded Highway and Railway Bridges, 1956, of the American Welding Society. All operators and processes shall be qualified in accordance with the foregoing specification for the type of electrode and position in which the work will be performed.
 The fabricator is to furnish to the Highway Commission satisfactory photographic evidence of the acceptability of the transverse welds in the flange plates of the girders. Butt welds marked (W) on this sheet are to be photographed full width of flange; butt welds marked (W) are to be photographed at least half width of flange. These photographs are to show the internal structure of the welds, and may be made by the use of x-ray, radium, radio-active cobalt, or other approved process, at the option of the fabricator. Cost of this photographic inspection is to be included in the price bid for structural steel.
 For all girder weld details see sheet 10

CONSTRUCTED AS SHOWN

Design for
TWIN 1172'0" x 30' CONTINUOUS WELDED GIRDER BRIDGES
 106'-6" End Spans 7-137'0" Interior Spans
 Concrete Floor & Substructures Aluminum Handrail
SUPERSTRUCTURE DETAILS
 Sta 750+00 N. of 750+20 S. Project No. I-80-7(5)270
CEDAR COUNTY
 Iowa State Highway Commission
 April 1959 Sheet 8 of 13
 Design 8659 Cedar County File No 20039

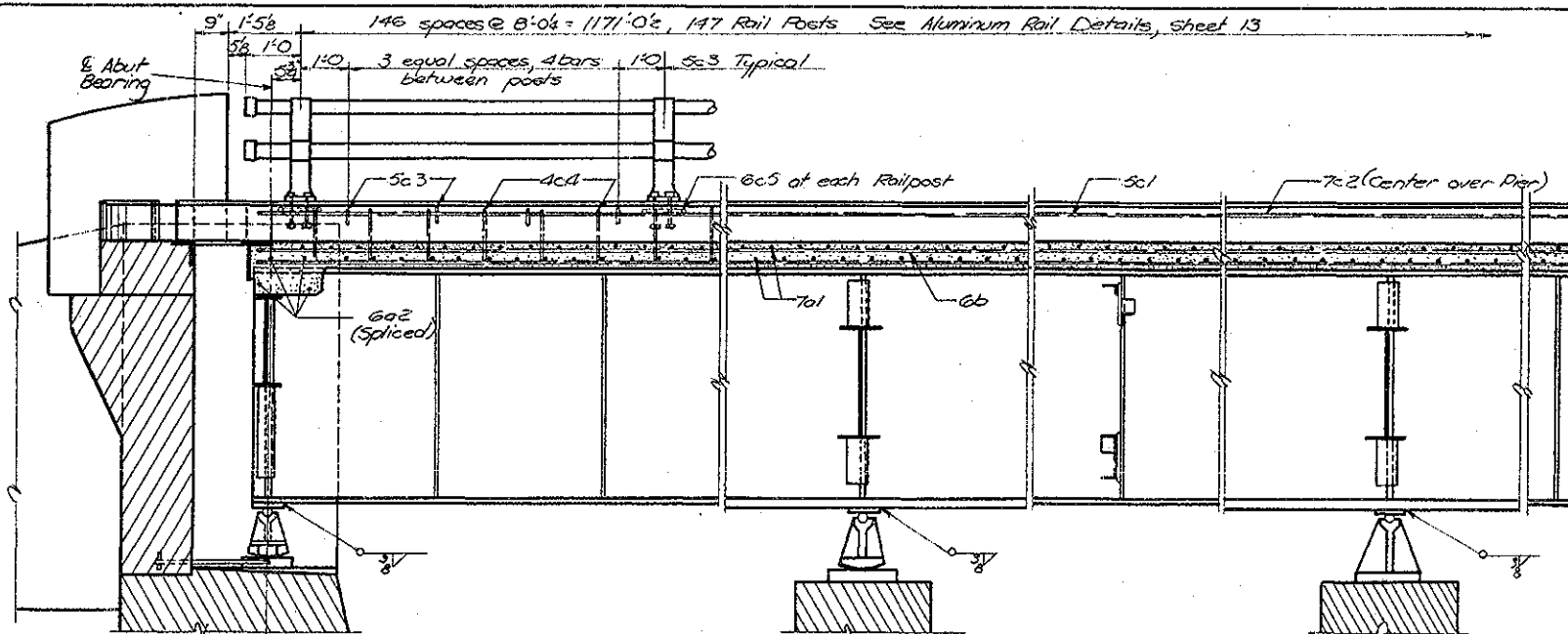

PART LONGITUDINAL SECTION NEAR CURB

CONCRETE PLACEMENT QUANTITIES		
Item		Cu. Yd.
Sections 1 & 2	2 @ 56.4	112.8
2	7 @ 52.8	369.6
10	8 @ 43.8	350.4
Curbs		223.9
Total, One Superstructure		1104.6

ESTIMATED QUANTITIES-ONE SUPERSTRUCTURE	
Item	Quantity
Concrete	1104.6 c.y.
Reinforcing Steel	341,484 lbs.
Structural Steel	1,369,745 lbs.

REINFORCING STEEL-ONE SUPERSTRUCTURE					
Bar	Location	Shape	No.	Length	Weight
7a1	Slab Transv. Top & Bot.	---	3745	32'-8"	220,056
6a2	Abutment Diaphragm	---	16	15'-1"	362
6b1	Slab Longitud. End Span	---	148	33'-2"	8484
6b2	" " " Int. "	---	518	37'-4"	29,046
6b3	" " " Over Pier "	---	692	33'-9"	30,110
5c1	Curb Longitud.	---	256	37'-11"	10,124
7c2	" " " Over Pier "	---	32	40'-0"	2,616
5c3	" Transverse	---	1168	2'-9"	3,350
4c4	" " "	---	1874	4'-0"	5,007
6c5	" Rail Post Anchor	---	294	5'-6"	2,429
Total					341,484

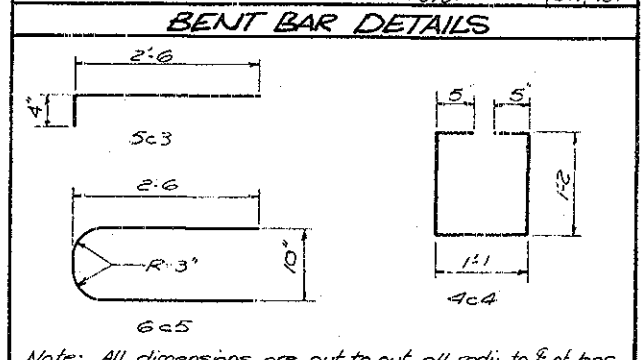

SUPERSTRUCTURE NOTES

These bridges are designed for H20-516 Loading plus 19 lbs. per sq. ft. of roadway for future wearing surface, and for alternate loading designated in DPM 20-4, Section 4-C.

The floor slab as shown includes 1/2" of wearing surface.

Field Connections may be riveted or bolted, except as noted or shown. Splice connections, if bolted, will require "High Tensile Strength Bolts". Structural Steel Weights have been computed using "High Tensile Strength Bolts".

All open holes are to be 1/2" and rivets and bolts are to be 3/8" unless otherwise noted.

Bottom flanges of girders are to be perpendicular to webs of reaction points. Girder splices are to be subpunched and reamed. Before reaming, all girders are to be assembled to proper camber as shown on sheet 8, "Girders as Fabricated and Erected", for inspection. After inspection, holes are to be reamed and all parts match-marked.

Masonry plates are to be set in paint and canvas. Bearing surfaces of unfinished masonry plates are to be flat and true.

Shop coat of paint is to be omitted on all steel surfaces in contact with concrete. Parts inaccessible after erection are to be given three coats of paint in the shop.

The structural steel for main stress carrying members shall conform with specifications for ASTM A-373 Steel.

Girder splice points are to be supported by false work or other means, as directed by the engineer and adjusted as closely as possible to dimensions shown on diagram "Girders as Fabricated and Erected" before riveting or bolting is completed.

SPECIFICATIONS

Design: AASHTO Series of 1957 and AASHTO tentative specifications series T(68).
 Construction: Standard specifications of the Iowa State Highway Commission, series of 1956, plus current special provisions.

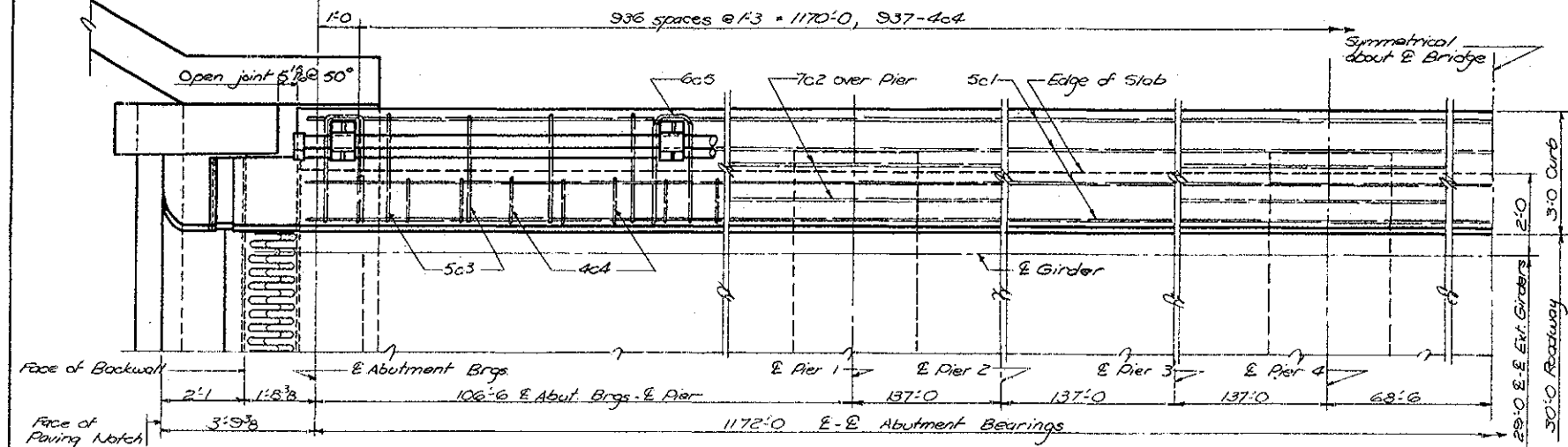

PART PLAN
Scale 1/2" = 1'-0"

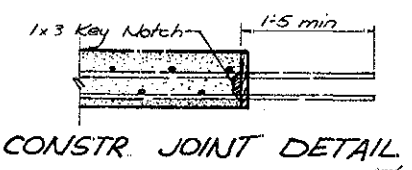

CONSTR. JOINT DETAIL

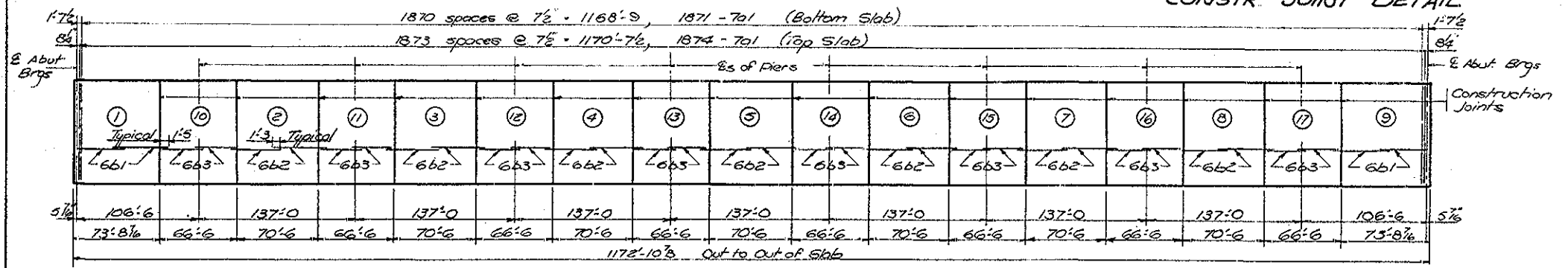

SLAB CONCRETE AND REINFORCING DIAGRAM
 Slab sections over piers are to be placed last. Curbs may be placed continuously. Encircled figures indicate recommended slab pouring sequence.

CONSTRUCTED AS SHOWN

Design For
TWIN 117'x30' CONTINUOUS WELDED GIRDER BRIDGES
 106'-6" End Spans 7-137'-0" Interior Spans
 Concrete Floor of Substructures Aluminum Rail

Sta 750+00.00 N.G. 750+20.00 S. Project No. I-80-7(5)270

CEDAR COUNTY
 Iowa State Highway Commission
 April 1959 Sheet 9 of 13

Design 8859 Cedar County File 20035

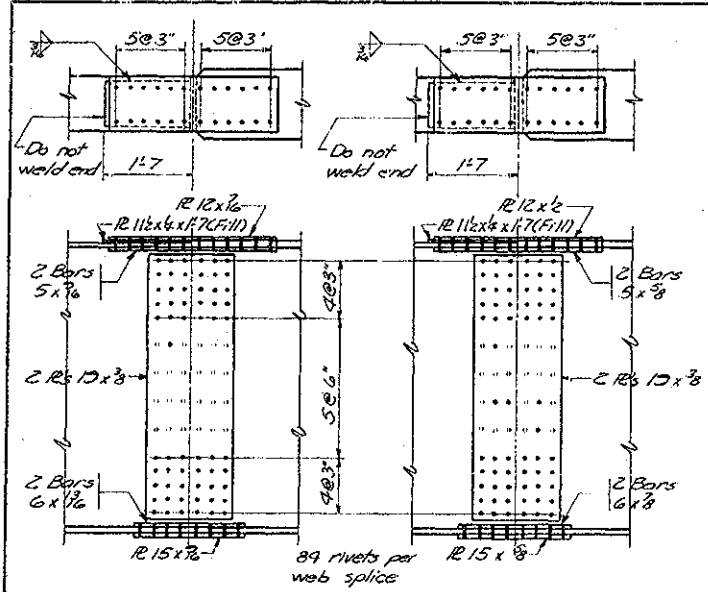

Note For Rail & post details see sheet 13

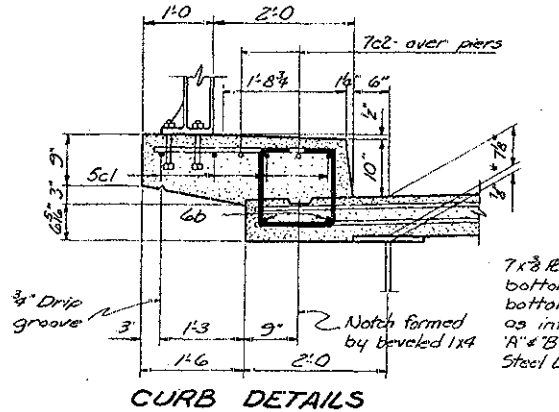

CURB DETAILS

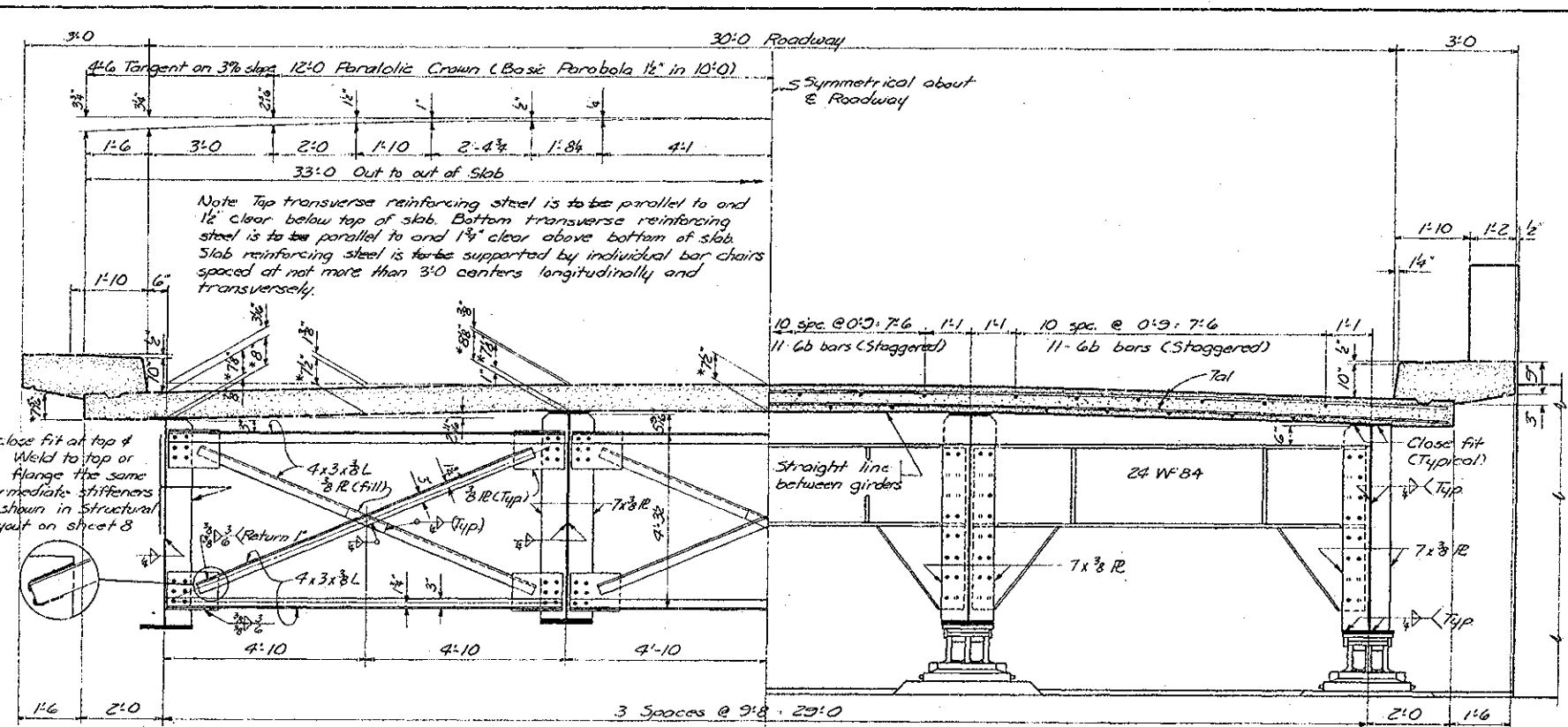

HALF INTERMEDIATE SECTION (Handrail Not Shown)
* Indicates nominal dimensions

HALF SECTION NEAR ABUTMENT

EXTERIOR GIRDER INTERIOR GIRDER SPLICE DETAILS

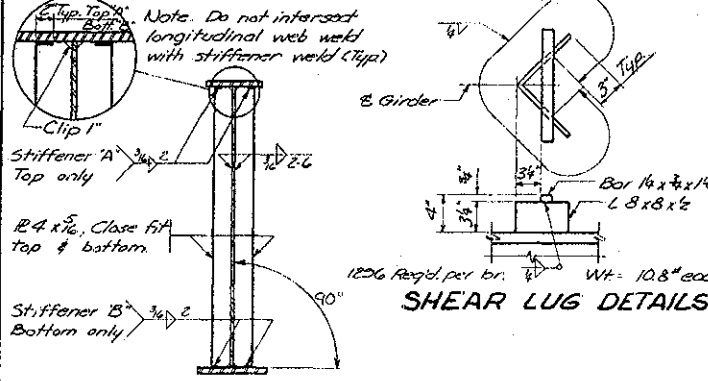

INTERMEDIATE GIRDER STIFFENERS

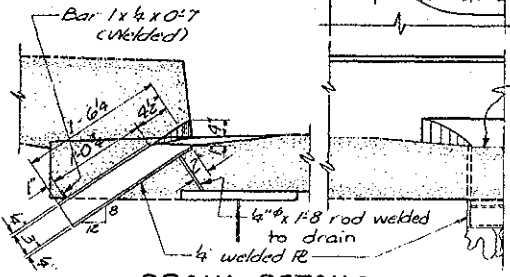

DRAIN DETAILS

68 Drains reqd. per bridge Wt = 26.4# each (See Situation Plan for location)
Note: Rolled tube 4"x8" O.D. with 1/2" wall thickness may be substituted for the welded floor drain shown. Dimensions shown are for 1/2" welded R.

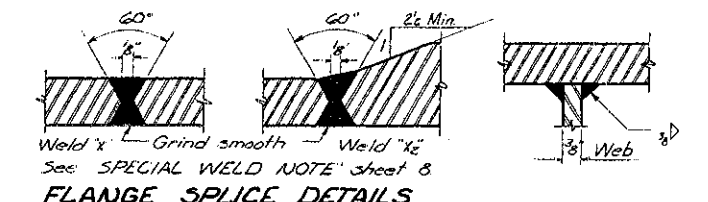

FLANGE SPLICE DETAILS

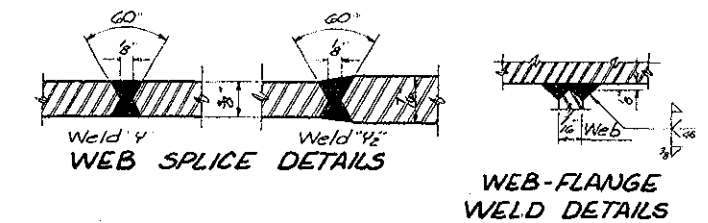

Note. Web to Flange Welds
It will not be necessary to bevel web plates if a satisfactory weld, with full penetration, can be made by using an automatic or semi-automatic submerged arc system, provided neither the depth of fusion nor the total width of fusion at any point in a single weld or weld pass exceeds the width of the face of the weld or pass. Square Tee joints with web plates 3/8" max. thickness are prequalified. Square Tee joints with web plates over 3/8" thick will require specific approval as follows. The contractor shall make up a sample, one foot long, of the same cross section and same materials, with the same edge preparation (gouging, beveling etc. to comply with depth of fusion requirements above) as the joint he proposes to use in construction, and submit it to the Highway Commission to be approved or rejected as an alternate joint, before proceeding with the welding.

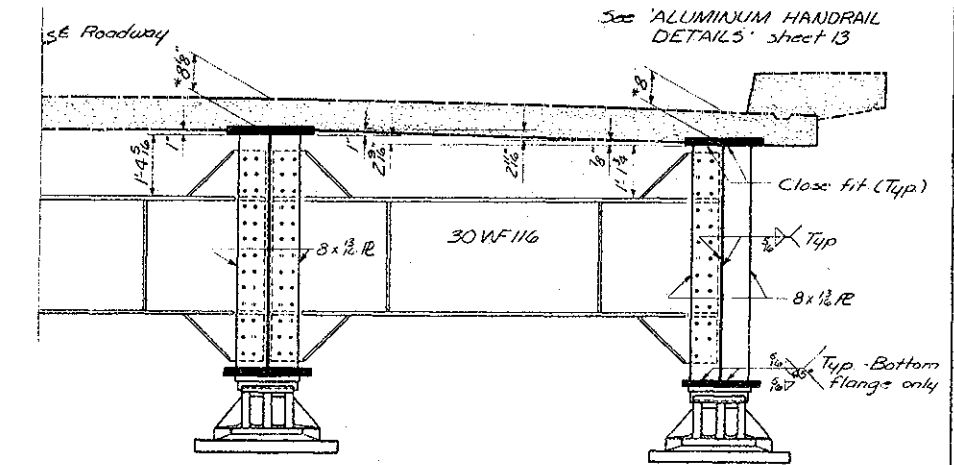
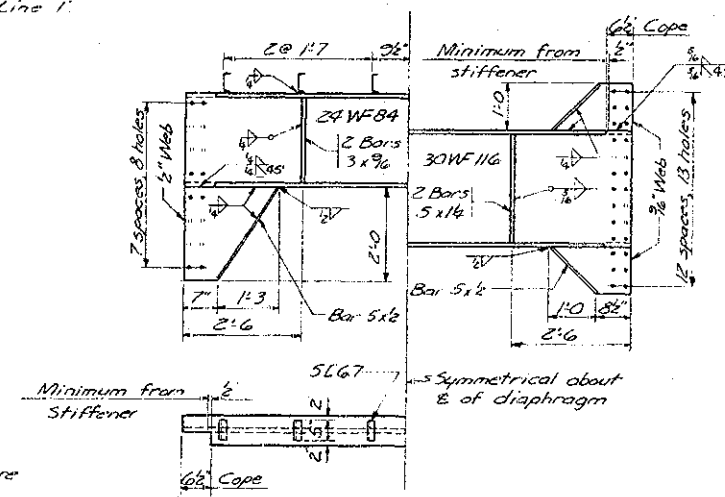

HALF SECTION NEAR PIER (Handrail Not Shown)

CONSTRUCTED AS SHOWN

TABLE OF MOMENTS IN FOOT KIPS										
Negative Moments					Positive Moments					
Pier 1-8		Pier 2-7		Pier 3-6		Pier 4-5		End Spans		
Ext.	Int.	Ext.	Int.	Ext.	Int.	Ext.	Int.	Ext.	Int.	
D.L. #1	1478	2250	1481	2224	1489	2237	1486	2232	534	802
D.L. #2	303	144	242	150	242	150	242	150	470	75
Unif. LL	750	1006	842	1129	840	1152	858	1152	312	687
Conc. LL	258	346	272	365	272	365	272	365	279	375
Impact	204	274	213	285	216	290	210	290	171	229
Total	3613	4020	3750	4153	3875	4194	3798	4199		

TABLE OF REACTIONS IN KIPS																			
Abutments				Pier 1-8				Pier 2-7				Pier 3-6				Pier 4-5			
Ext.	Int.	Ext.	Int.	Ext.	Int.	Ext.	Int.	Ext.	Int.	Ext.	Int.	Ext.	Int.	Ext.	Int.	Ext.	Int.		
30.3	95.5	115.5	173.3	113.8	171.0	114.2	171.4	114.0	171.2	23.8	3.8	82.4	13.0	83.7	13.2	83.4	13.1		
42.1	56.5	62.0	83.1	65.7	88.3	65.7	88.3	65.7	88.3	9.1	12.2	15.1	20.2	15.8	21.2	15.8	21.2		
105.3	118.0	222.0	312.4	226.0	316.5	226.1	316.6	225.9	316.6										

Design for
TWIN 1172' x 30' CONTINUOUS WELDED GIRDER BRIDGES
 106:6 End Spans 7-13:0 Interior Spans
 Concrete Floor & Substructure Aluminum Handrail

SUPERSTRUCTURE DETAILS

Station 750+00.00 North Lane
 Station 750+2000 South Lane
 Project No. I-80-7(5)270

CEDAR COUNTY
 Iowa State Highway Commission

April 1959
 Design 8859 Cedar County, File No 20032

Sheet 10 of 13

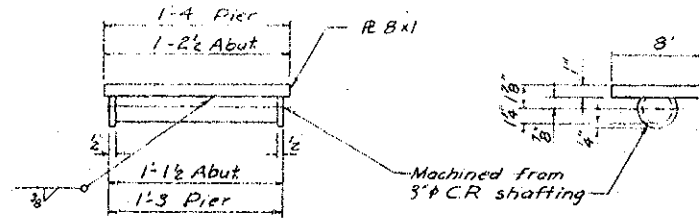
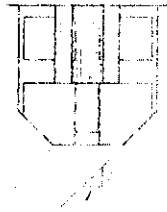
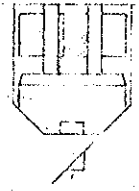

SOLE PL & PIN
(Abutment & Pier)
Scale 1/2" = 1'-0"

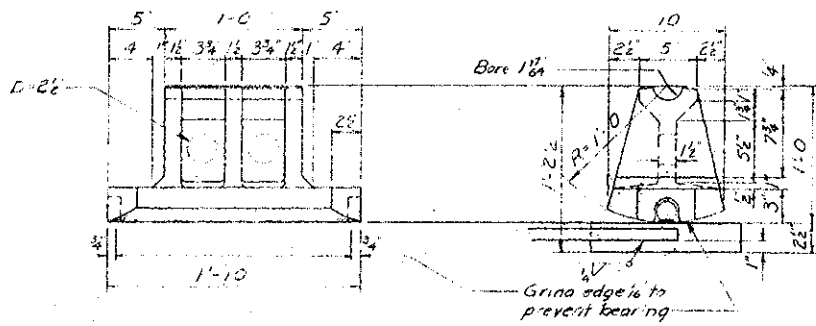
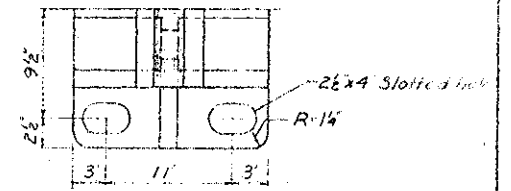

Wt. 241 lbs. each
ABUTMENT ROCKER

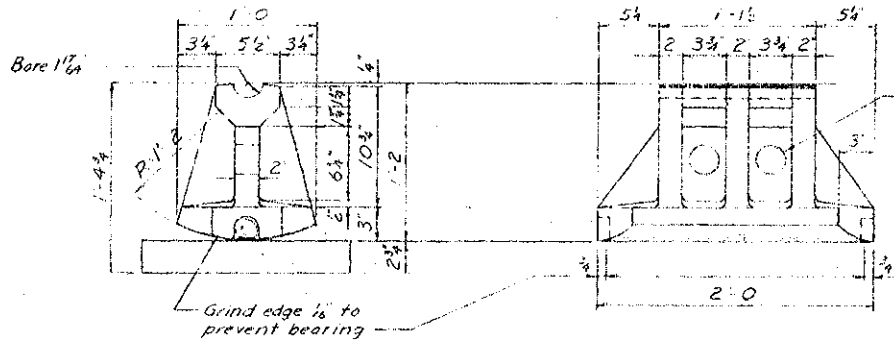

Wt. 427 lbs. each
PIER ROCKER

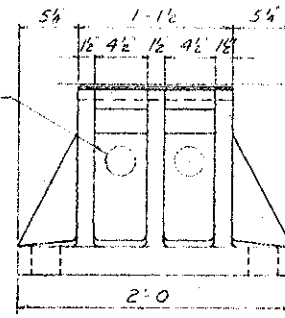

Wt. 554 lbs. each
PIER FIXED SHOE
16 Req'd
Scale 1/2" = 1'-0"

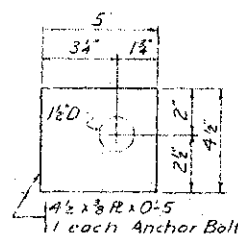

WASHER
Scale 3" = 1'-0"

Note: 256-14 x 11-8 swaged anchor bolts with heavy lock nuts are required for pier bearings. Set to project 5" above concrete. After bearing is in correct location, mortar to be poured around bolts to fill holes in masonry plates and shoes.

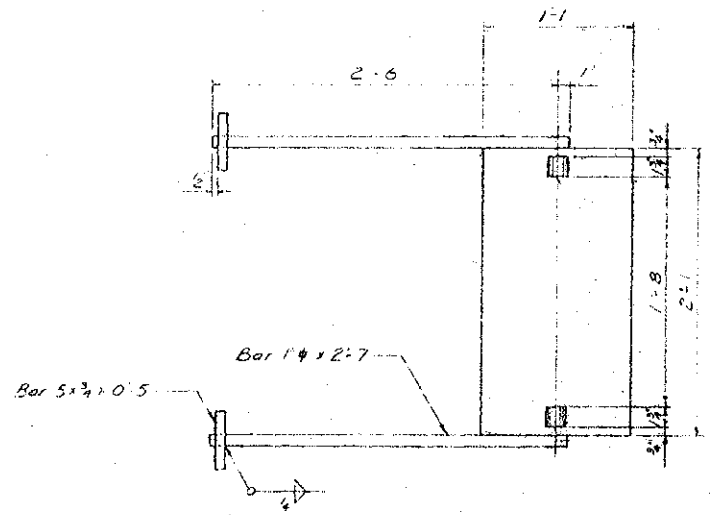

ABUTMENT MAS PL
16 Req'd

Scale 3/8" = 1'-0"

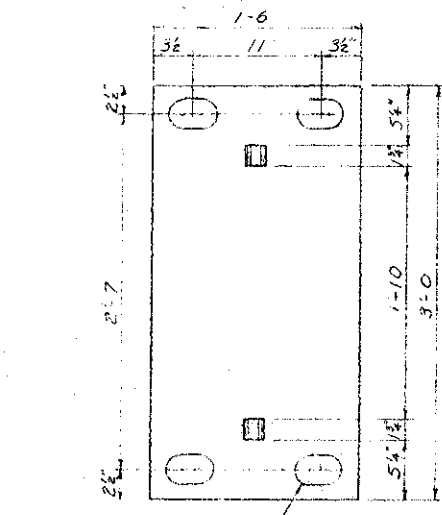

PIER MAS PL
48 Req'd

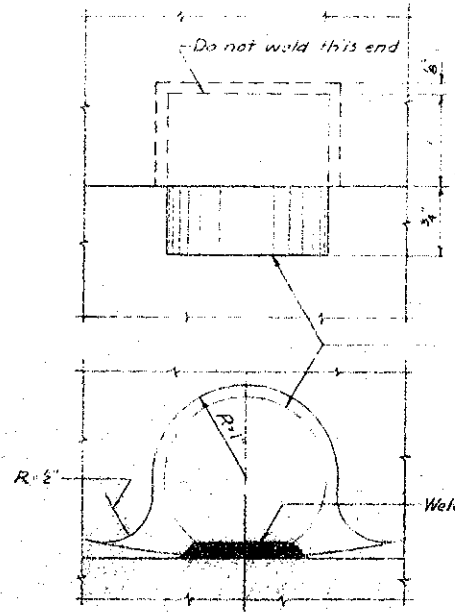

ROCKER PINTLE (TYP)
Scale 1/2" = 1'-0"

ROCKER SETTING TABLE										
Temperature at time of setting	Abut	Pier 1	Pier 2	Pier 3	Pier 4	Pier 5	Pier 6	Pier 7	Pier 8	Abut
10°F	-1 1/16"	-1 1/2"	-1 1/16"	-5/8"				-5/8"	-1 1/2"	-1 1/16"
50°F	0	0	0	0	Fixed	Fixed	0	0	0	0
90°F	+1 1/16"	+1 1/2"	+1 1/16"	+5/8"			+5/8"	+1 1/2"	+1 1/16"	+1 1/16"

Note: Tilt rockers in direction shown for temperatures above 50°F, and in opposite direction for temperature below 50°F. Settings for other temperatures are proportional.

CONSTRUCTED AS SHOWN

Design for
TWIN 117'2" x 30' CONTINUOUS WELDED GIRDER BRIDGES
106'-6" End Spans 7 - 137'-0" Interior Spans
Concrete Floor & Substructures Aluminum Rail
BEARING DETAILS
Sta 750+00.00 N. & 750+20.00 S. Project I-80 7(5) 270
CEDAR COUNTY
Iowa State Highway Commission
April 1959 Sheet 11 of 13
Design 8859 Cedar County

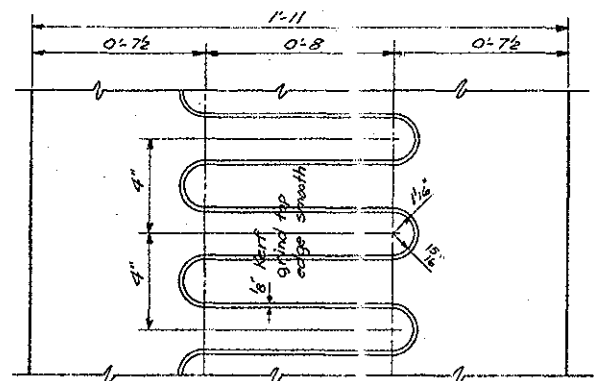

TOOTH LAYOUT
Flame cut from 23 1/2" R
Scale: 3/4"=1'-0"

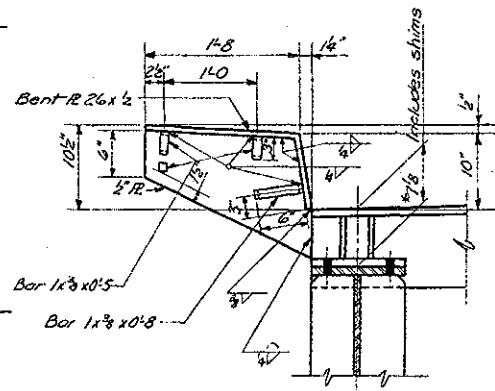

VIEW E-E
Scale 1"=1'-0"

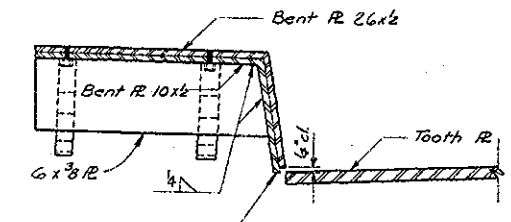

SECTION F-F
Scale 1 1/2"=1'-0"

7/8" x 2 slots in 26x1/2 R, 7/8" holes in 10x1/2 R for 1/2" x 1/4" bolts with washers. Weld nuts to underside of 10x1/2 R. Remove bolts when concrete has taken initial set.

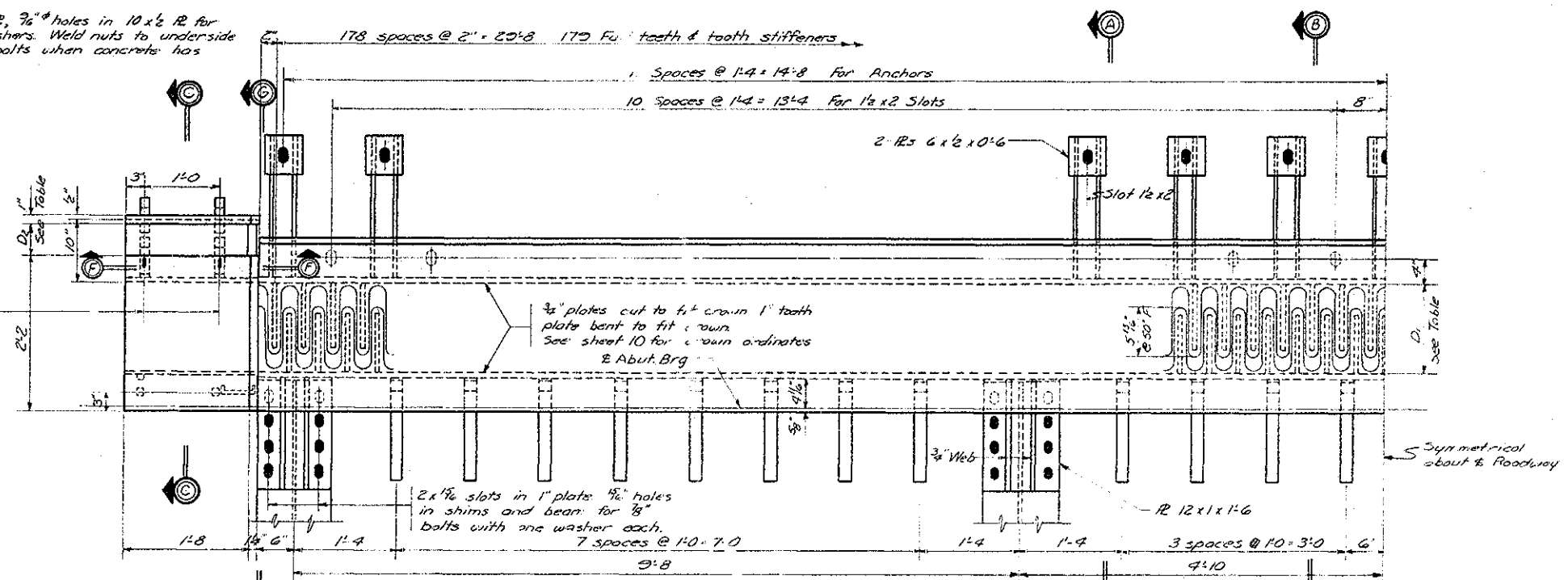

PLAN
Scale 1"=1'-0"

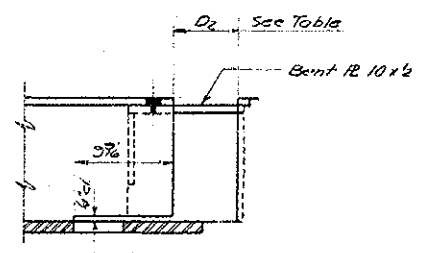

SECTION G-G
Scale 1 1/2"=1'-0"

TEMP TABLE

TEMP	East Abut		West Abut	
	D ₁	D ₂	D ₁	D ₂
10°F	1'-4 1/2"	6 1/2"	1'-4 1/2"	6 1/2"
50°F	1'-2 1/2"	4 1/2"	1'-2 1/2"	4 1/2"
30°F	1'-1 1/2"	2 1/2"	1'-1 1/2"	2 1/2"

Note A expansion details required Weight each = 7740 lbs (including all bolts except for connecting to main girders)

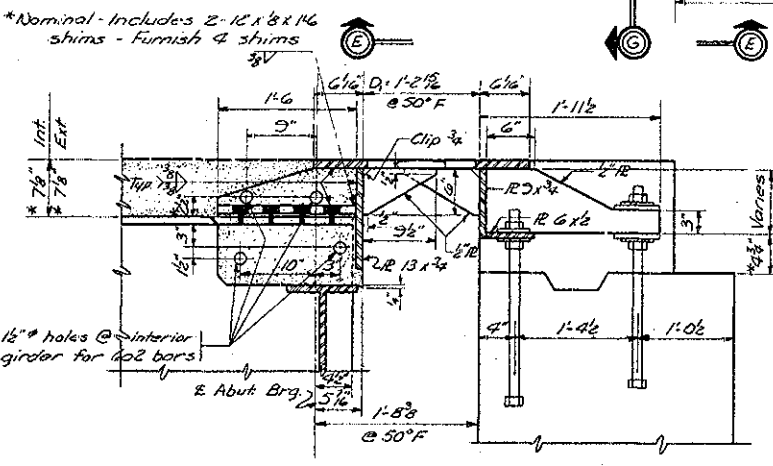

SECTION A-A

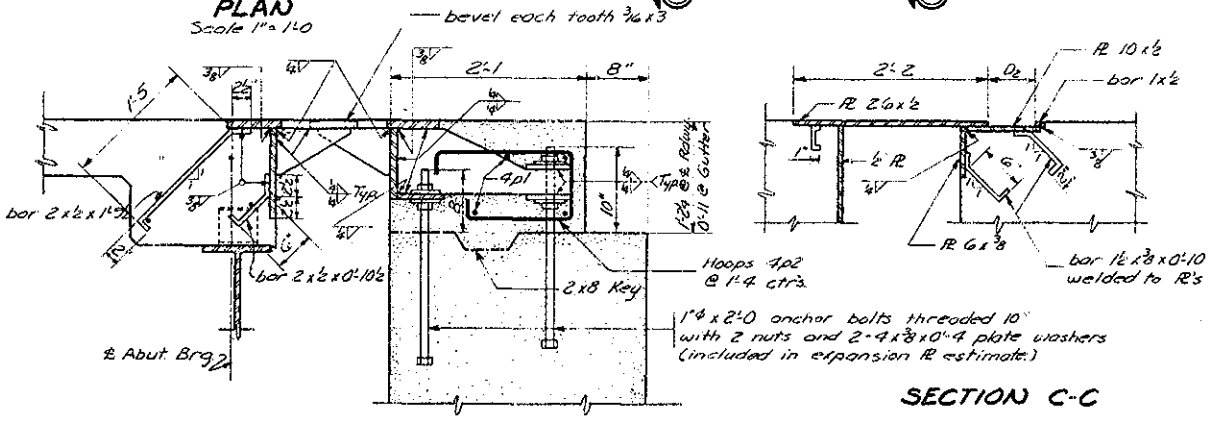

SECTION B-B

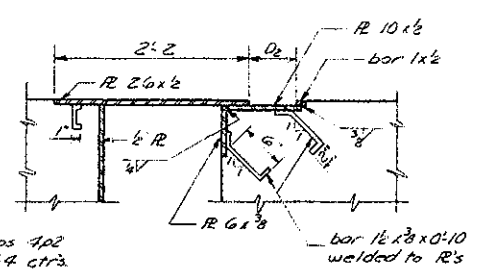

SECTION C-C

Constructed as Shown

Design for
TWIN 1172'-0 x 30' CONTINUOUS WELDED GIRDER BRIDGE
10'-6" End Spans 7'-137'-0 Interior Spans
Concrete Floor and Substructures Aluminum Rail
EXPANSION PLATE DETAILS
Station 750+0000 North Lane Project I-80-7(5)1270
Station 750+2000 South Lane
CEDAR COUNTY
Iowa State Highway Commission
April 1959 Sheet 12 of 13
Design 6859 Cedar County File No 20039

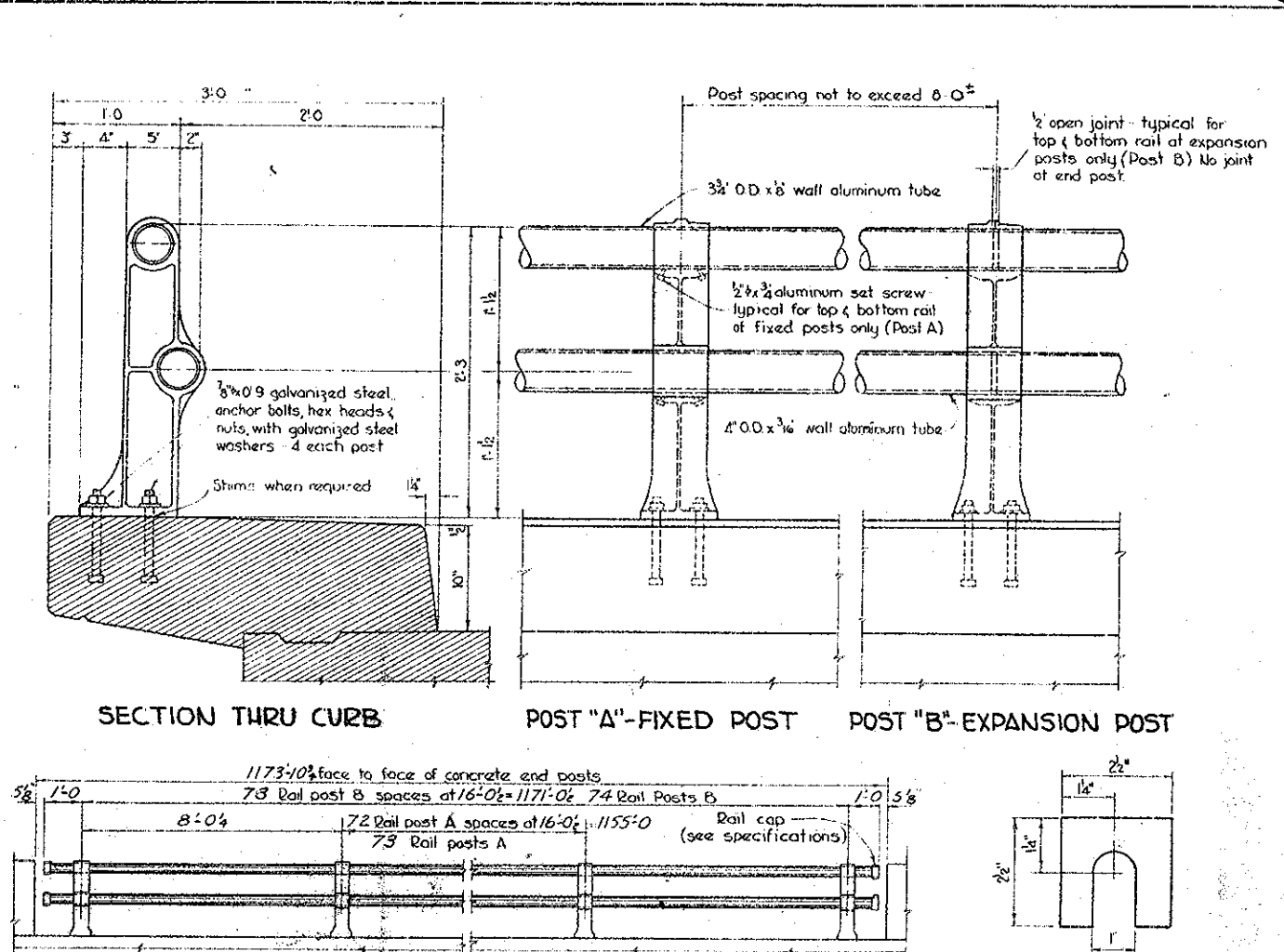
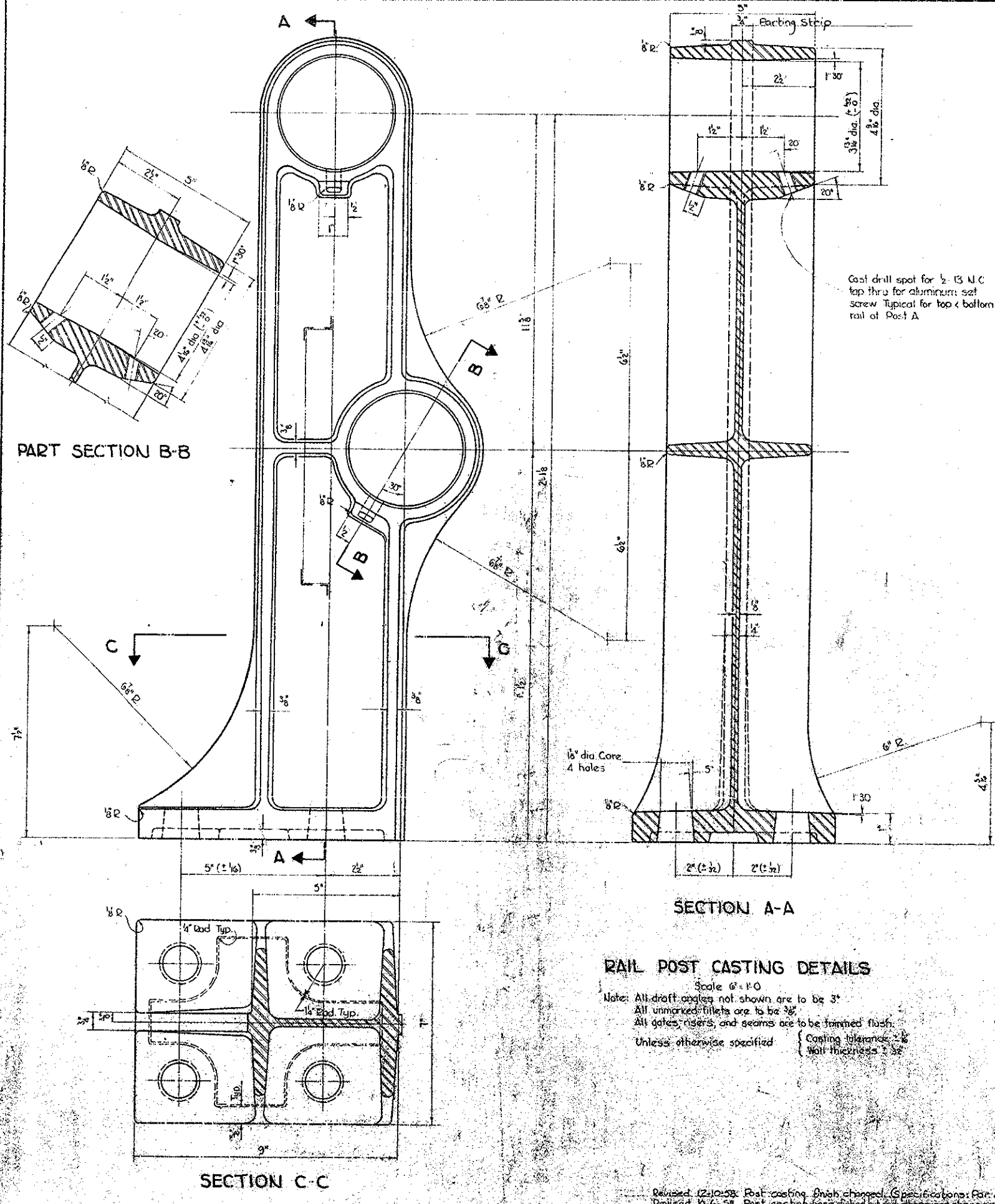

SPECIFICATIONS:

- 1 DESCRIPTION OF BID ITEM

A. Aluminum handrail is to be bid on a linear foot basis measured from center to center of end posts. The price bid for "Aluminum Handrail" shall consist of furnishing, fabricating, erecting, and cleaning all metal handrail and shall include the furnishing and installation of anchor bolts and all other incidental items in accordance with these plans and specifications.
- 2 COMPONENT PARTS AND MATERIALS

A. Aluminum Bridge Rail Tubing
 1. Aluminum tubing shall comply with the A.S.T.M. Specification B235 - * alloy 6061 condition T6 (commercial designation 6061-T6). The aluminum tubing shall be fabricated in two panel sections as detailed. The rail shall be fixed at alternate posts with set screws and allowed to expand at adjacent posts.
 2. The aluminum rail tubing shall be closed at the ends next to the concrete end posts, as detailed, by means of cast caps or plugs or by means of welded end plates. The cast caps or plugs shall comply with the material specifications as outlined for post castings.

B. Aluminum Rail Post Castings
 1. Aluminum post castings shall comply with:
 (a) The A.S.T.M. Specification B108 - * alloy 6061 condition T6 for aluminum alloy permanent mold castings (commercial designation aluminum alloy permanent mold castings 356-T6) or
 (b) The A.S.T.M. Specification B26 - * alloy 356-T6 condition T6 for aluminum alloy sand castings (commercial designation aluminum alloy sand castings 356-T6).
 2. The post castings shall have smooth and even surfaces, free from shrinkage cracks, oxide inclusions, and other defects.
 3. The post castings shall follow the outlines and dimensions as detailed. Minor changes, such as draft angles and radii for fillets and corners, shall be permitted. Draft in front and back face of post may be omitted providing minimum wall thicknesses as detailed, are maintained. Shop drawings for post castings must be submitted and approved by the Engineer before castings are made.
 4. The parting strip is to be finished with a 120-grit finish or an approved equal. All other surfaces are to have a uniformly polished or burnished finish.
 5. Before setting posts, the entire base of the post casting shall be coated with an aluminum impregnated caulking compound, 1/8" thick. The caulking compound shall comply with Federal Specification F-C-396 for knife grade, to which shall be added aluminum paste conforming with Paragraph 4195.03 in proportion to one pound of aluminum to 5 pounds of caulking compound.

C. Aluminum Set Screws for Posts A
 1. Aluminum set screws shall comply with the A.S.T.M. Specification B211 - * alloy 6062 aluminum commercial designation 6062-T6 with N-205 aluminum finish. The finished set screws shall be supplied in the 1/4" diameter and shall be given an anodic coating of at least 0.0002" in thickness, and chloride treated. The set screws shall have a hexagonal socket head and shall comply with the following dimensions:
 2. Aluminum Shims
 1. Aluminum shims shall comply with the A.S.T.M. Specification B-221 - * alloy 350-A condition O (commercial designation 350-O).
- 3 CONSTRUCTION

A. The specifications for construction shall be the Standard Specifications of the Iowa State Highway Commission Series of 1956 plus current Special Provisions with the added provisions.
 1. The anchor bolts for the aluminum posts shall be set at the line and elevations shown on the plans. They shall be firmly held in place by suitable templates that will assure their correct position during the placement of concrete. Aluminum shims as detailed, shall be used if necessary to insure the correct elevation of the rails.
 2. The cast aluminum posts and the aluminum tube rails shall be carefully handled during their unloading, handling, and erection. Members that are marred, disfigured or damaged to the extent that they impair their usefulness or appearance shall be rejected and replaced at the contractor's expense.
 3. The aluminum handrail shall be stored above ground upon suitable platforms and kept free from dirt, grease, and contact with dissimilar metals. The stored aluminum handrail shall be protected from moisture as far as practical.
 4. After anchor bolts have been tightened, the excess caulking compound shall be removed and all openings around the base of the post pointed full and flush with caulking compound.
 5. After erection, rails and posts and the concrete around the post bases shall be thoroughly cleaned of all dirt, grease, caulking compound and other foreign material by an approved means as directed by the Engineer.
 6. The ends (about 2") of both rails at Post "B" are to be wrapped with friction tape before being set in the hubs in order to produce a tight fit and prevent rattling. (Approved ~~materials~~ or shims may be substituted.)

RAIL POST CASTING DETAILS

Scale 6" = 1'-0"
 Note: All draft angles not shown are to be 3°.
 All unmarked fillets are to be 3/8".
 All gates, risers, and seams are to be trimmed flush.
 Unless otherwise specified: Casting tolerances: ± 0.010"
 Wall thickness: ± 0.010"

ALUMINUM HANDRAIL QUANTITIES

Aluminum Handrail (E-L End Posts)	* 2342.1 lin. ft.
-----------------------------------	-------------------

* Total each Lane **Constructed as Shown**

TWIN 117'x30' CONTINUOUS WELDED GIRDER BRIDGES

106-6 End Spans 7-137-0 Interior Spans
 Concrete Floor & Substructure Aluminum Rail

ALUMINUM HANDRAIL DETAILS

Station 750+00.00 N
 750+00.00 S
CEDAR COUNTY

Iowa State Highway Commission
 April 1959
 Project I 80-763270
 Sheet 13 of 13