



Reinforced Concrete Pedestrian Tunnel Standards

General Notes:

- The reinforced concrete pedestrian tunnel sections are designed for HL-93 live load and earth fills of varying heights.
- Vertical earth pressure, $EV=0.120$ kcf.
Horizontal earth pressure, $EH_{max} = 0.060$ kcf max, $EH_{min} = 0.030$ kcf.
- The reinforced concrete pedestrian tunnel sections are designed for Class 1 exposure conditions except:
Class 2 exposure condition is utilized for the slab design in 0' fill instances.
- All slab and floor reinforcing steel is to be supported at intervals of not more than 3'-0" in either direction as outlined in the Standard Specifications.
- The clear distance from face of concrete to near edge or end of reinforcing bar to be 2" unless otherwise noted.
- Except for dowel bars 5r1 in slab, longitudinal reinforcing is not to extend thru the construction joints.
- Floor of barrel shall receive a broomed finish meeting the requirements of Article 2511.03,B,3,b, of the Standard Specifications and meet the smoothness requirements of Article 2511.03,B,5,b, of the Standard Specifications. Sides of footing are to be formed to ensure correct line and grade. Following broom finishing of the sidewalk surface, apply white pigmented liquid curing compound to the sidewalk in accordance with Section 2301.03,K,2, of the Standard Specifications. Do not damage the broom finish by using additional curing methods that include fabric, plastic, or other covers during the initial curing period. Ensure that coverings will not damage the broom finish by waiting until surface has sufficiently set before application.
- The permissible construction joint at the top of the walls may be lowered at the Contractor's option with Engineer's approval.
- The reinforcement supplied for this structure shall be Grade 60 reinforcement in accordance with the Standard Specifications. The design stresses are based on Grade 60 reinforcement.
- The vertical bars in the walls may be spliced above the footing at the Contractor's option as follows:

Bar Size Number	4	5	6	7
Minimum Splice Length	20"	24"	29"	34"

This splice, if used, will be at the Contractor's expense.

- Reinforcing bar clearances will be as follows:
Edge clearances: 2" except
Top of floor 2¼" to near transverse reinforcing bar
Bottom of floor 3½" to near transverse reinforcing bar
End clearances:
Vertical top 2"
Vertical bottom 3" or 3½" if overall height of the culvert is not to a full inch
Transverse 2"
- These pedestrian tunnel standards label all reinforcing steel with English notation (5a1 is ⅝ inch diameter bar). English reinforcing steel received may display the following "bar designation". The "bar designation" is the stamped impression on the reinforcing bars, and is equivalent to the bar diameter in millimeters.

English Size	4	5	6	7	8	9
Bar Designation	13	16	19	22	25	29

- All reinforcing bars and bars noted as dowels supplied for this structure shall be deformed reinforcement unless otherwise noted or shown.
- All construction joints shall be formed with a beveled keyway except at bell joints.
- All beveled keyways shall be centered.
- Keyway size shall be 2"x4" except the keyway between the barrel floor and wall and the headwall apron and wingwall shall be 2"x6".

General Notes Continued:

- Keyway dimensions shown on the plans are based on nominal dimensions unless stated otherwise. In addition, the bevel used on the keyway shall be limited to a maximum of 10 degrees from vertical.
- If 0' of fill is specified, details for paving notch and reference to epoxy coating of slab reinforcing steel, if applicable, shall be included in the final plans.
- All dimensions are in feet and inches unless otherwise noted or shown.
- PVC waterstop shall be applied to the transverse construction joints in the slab, walls, and floor. PVC waterstop shall be installed in accordance with the Manufacturer's recommendations. Omit PVC waterstop when bell joints are used. The following is a listing of approved PVC waterstop:
 - Greenstreak #738
 - Southern Waterstops 25RCB
 - Approved Equal
- Bentonite waterstop shall be applied to the longitudinal construction joints at the top and bottom of the walls. Bentonite waterstop shall be installed with a Manufacturer's approved adhesive in accordance with the Manufacturer's recommendations. The following is a listing of approved bentonite waterstop:
 - Greenstreak Swellstop
 - Henry Hydro-Flex
 - Approved Equal
- Bentonite waterstop shall be protected from exposure to moisture prior to concrete placement. Bentonite waterstop that has swelled prior to concrete placement shall be replaced at no cost to the State.
- Waterproof membrane shall be applied to the outside face of the transverse construction joints in the slab and walls. Waterproof membrane shall be installed with a Manufacturer's approved adhesive in accordance with the Manufacturer's recommendations. Omit waterproof membrane when bell joints are used. The following is a listing of approved waterproof membrane:
 - W.R. Meadows Mel-Rol
 - Grace Construction Products Bituthene 3000 (Below Grade)
 - Approved Equal

Index for Pedestrian Tunnel Standards:

PT G1-20	Index & General Notes
PT G2-20	Typical Tunnel Details
PT-RCB 12-11-20	Tunnel Details 12'-0" x 11'-4"
PT-RCB 12-12-20	Tunnel Details 12'-0" x 12'-4"
PT-RCB 14-12-20	Tunnel Details 14'-0" x 12'-4"
PT-FWH 0-1-20	Flared Wing Headwall Dimension Plan & Table
PT-FWH 0-2-20	Flared Wing Headwall Apron Layout & Curtain Wall Details
PT-FWH 0-3-20	Flared Wing Headwall Wing Layouts & Cross Section Details
PT-FWH 0-4-20	Flared Wing Headwall Quantity Tabulation
PT-CBJ 1-20	Pedestrian Tunnel Bell Joints
PT-CBJ 2-20	Pedestrian Tunnel Bell Joints
PT-SR 1-20	Safety Rail Details
PT-SR 2-20	Safety Rail Details
PT-AD 1-20	Aesthetic Treatment General Notes
PT-AD 2-20	Pedestrian Tunnel Textured Concrete



Specifications:

Design:
AASHTO LRFD Bridge Design Specifications, 8th Ed., Series of 2017.

Construction:
Iowa Department of Transportation Standard Specifications for Highway and Bridge Construction, current series, plus applicable General Supplemental Specifications, Developmental Specifications, Supplemental Specifications and Special Provisions.

Design Stresses:

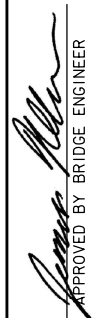
Design stresses for the following materials are in accordance with the AASHTO LRFD Bridge Design Specifications, 8th Ed., Series of 2017:
Reinforcing steel in accordance with AASHTO LRFD Section 5, Grade 60.
Concrete in accordance with AASHTO LRFD Section 5, $f'_c = 4.0$ KSI.

LATEST REVISION DATE	 APPROVED BY BRIDGE ENGINEER	 Cast-In-Place Standard Design - Walkways and Trails Reinforced Concrete Pedestrian Tunnel August, 2020	
		Index & General Notes	PT G1-20

*The k9 and m9 bars are to be placed in the top slab and bottom floor unless the horizontal legs of the k2 and m2 bars touch or lap. The pedestrian tunnel barrel standards identify when the k9 and m9 bars are omitted.

Note:
Typical for lengths of 38', 35', 32', 29', and 26'. These lengths are shown as typical because all transverse and vertical reinforcing steel spacing repeats in 3'-0" intervals.

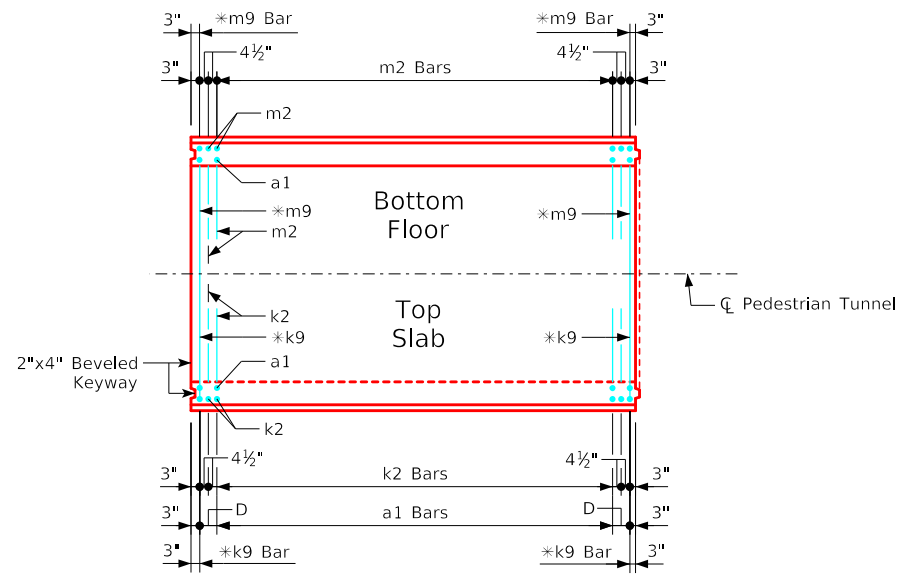

Standard Section Plan View
(Keyway is to be omitted when bell joints are used)

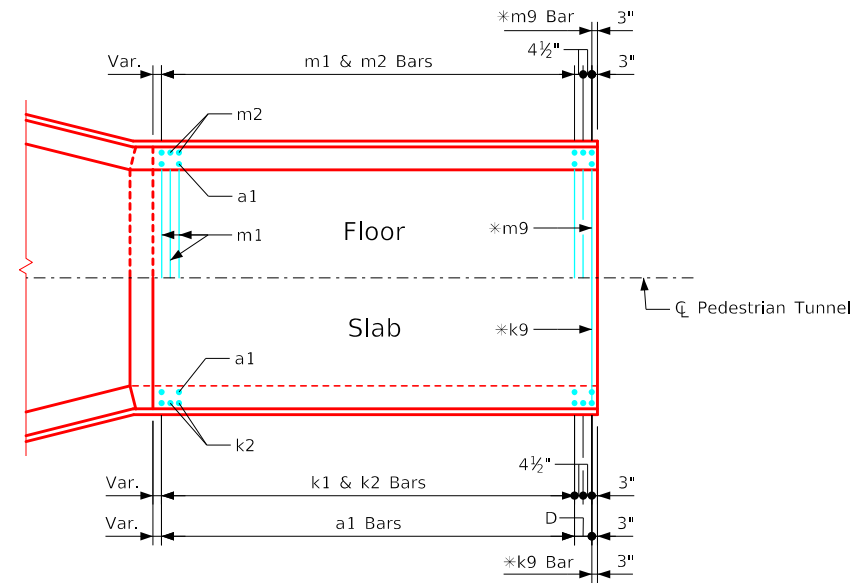

End Section Plan View
(Keyways not shown)

Note:
All longitudinal barrel steel shall extend at least to the backface of parapet.

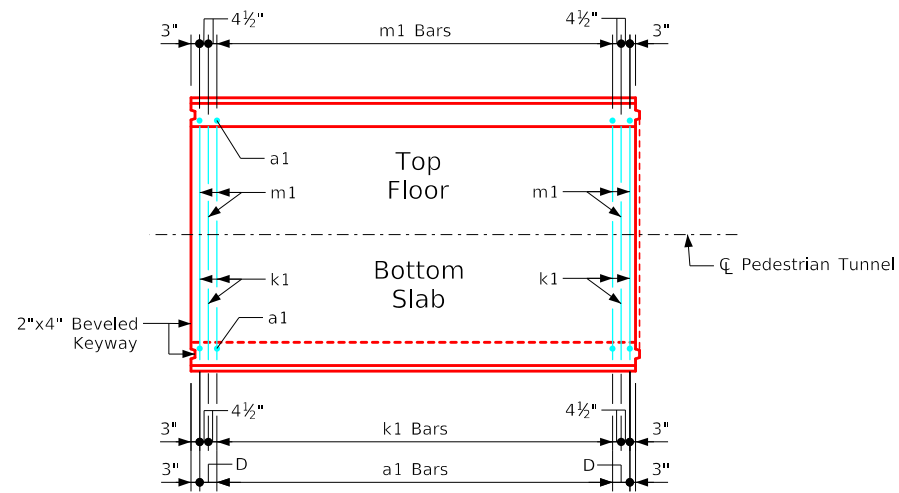

Standard Section Plan View
(Keyway is to be omitted when bell joints are used)

5r1 Bars - One Const. Jt.		
Span	No.	Weight (LB)
12'-0"	13	47
14'-0"	15	55

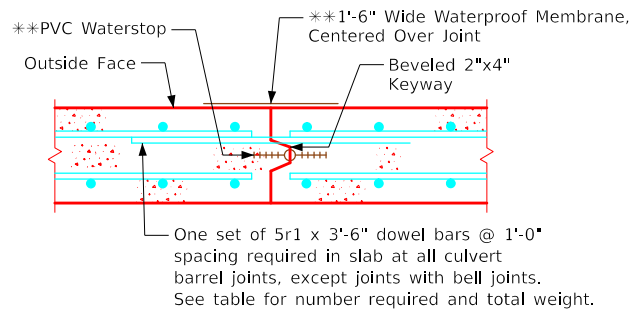

Slab Construction Joint Detail

**Note:
Omit PVC waterstop and waterproof membrane when bell joints are used.

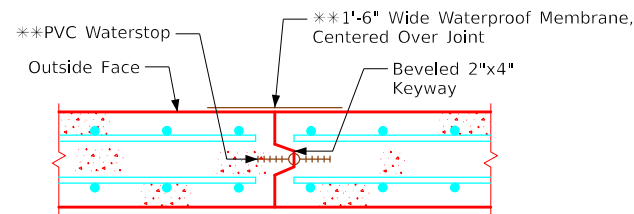

Wall Construction Joint Detail

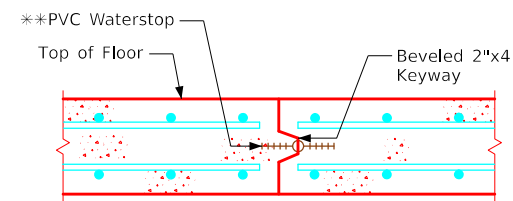

Floor Construction Joint Detail

Note:
Dimensions listed on this sheet to be used in conjunction with dimensions and quantities for barrel section sheets.

LATEST REVISION DATE	 APPROVED BY BRIDGE ENGINEER		
		Cast-In-Place Standard Design - Walkways and Trails Reinforced Concrete Pedestrian Tunnel August, 2020	
		Typical Tunnel Details	PT G2-20

Variable Dimensions and Quantities for 12'-0" x 11'-4" Barrel Sections

Dimensions								Bar List																												Quantities																					
								a1		b1			e1			e2			f1			f2			k1				k2				k9				m1			m2				m9				Concrete (CY/FT)				Steel (LB/FT)					
Fill	S	H	A	B	C	D		Size	Sp.	L	Size	Sp.	No.	Size	Sp.	No.	Size	Sp.	No.	Size	Sp.	No.	Size	Sp.	No.	Size	Sp.	L	Size	Sp.	L	Size	Sp.	L	Size	Sp.	L	Size	Sp.	L	Size	Sp.	L	Size	Sp.	L	Size	Sp.	L	Size	Sp.	L	Slab	Floor	Walls	Total	
0	12'-0"	11'-4"	13.5	14.5	11	9		4	12	13'-2"	4	6	44	5	12	11	4	16	10	4	12	13	4	16	10	8	12	13'-6"	6	9	12'-0"	8'-0"	4'-0"	--	--	7	9	14'-0"	6	9	19'-7"	8'-0"	11'-7"	--	--	0.571	0.615	0.745	1.931	291.58							
1	12'-0"	11'-4"	12.5	14	11	9		4	9	13'-1"	4	6	44	5	12	11	4	16	10	4	12	13	4	16	10	7	9	13'-6"	6	9	11'-11"	8'-0"	4'-0"	--	--	7	9	14'-0"	6	9	19'-7"	8'-0"	11'-7"	--	--	0.571	0.615	0.745	1.931	291.58							
2	12'-0"	11'-4"	8.5	10.5	11	9		4	12	12'-5"	4	6	44	5	12	11	4	16	10	4	12	13	4	17	8	8	9	13'-6"	7	9	10'-2"	6'-2"	4'-0"	7	13'-6"	7	6	14'-0"	7	9	16'-4"	5'-1"	11'-3"	7	14'-0"	0.400	0.460	0.745	1.605	340.34							
3	12'-0"	11'-4"	8	10.5	11	9		4	12	12'-5"	4	6	44	4	12	11	4	17	8	4	12	13	4	16	8	8	9	13'-6"	7	9	8'-11"	5'-0"	3'-11"	7	13'-6"	6	6	14'-0"	7	9	16'-0"	4'-9"	11'-3"	7	14'-0"	0.379	0.460	0.745	1.584	310.53							
4-6	12'-0"	11'-4"	8	10.5	11	9		4	12	12'-5"	4	6	44	4	12	11	4	15	8	4	12	13	4	14	8	8	9	13'-6"	6	6	8'-1"	4'-6"	3'-7"	6	13'-6"	7	6	14'-0"	6	6	15'-8"	4'-5"	11'-3"	6	14'-0"	0.379	0.460	0.745	1.584	327.63							
7-9	12'-0"	11'-4"	8.5	11	11	9		4	12	12'-6"	4	6	44	4	12	11	4	13	8	4	12	13	4	13	8	7	6	13'-6"	6	6	7'-8"	4'-1"	3'-7"	6	13'-6"	7	6	14'-0"	6	6	15'-5"	4'-1"	11'-4"	6	14'-0"	0.400	0.483	0.745	1.628	329.32							
10-12	12'-0"	11'-4"	9.5	12.5	11	9		4	12	12'-8"	4	6	44	4	12	11	4	12	8	4	12	13	4	12	8	7	6	13'-6"	6	6	7'-8"	3'-10"	3'-10"	6	13'-6"	8	6	14'-0"	6	6	15'-3"	3'-10"	11'-5"	6	14'-0"	0.443	0.549	0.745	1.737	346.29							
13-15	12'-0"	11'-4"	10.5	13	11	9		4	9	12'-10"	4	6	44	4	12	11	4	13	8	4	12	13	4	17	6	7	6	13'-6"	7	9	8'-2"	4'-1"	4'-1"	7	13'-6"	8	6	14'-0"	7	9	15'-2"	3'-8"	11'-6"	7	14'-0"	0.486	0.571	0.745	1.802	344.92							

Bent Bar Details

Bars	D
6	4 1/2"
7	5 1/4"

k2 & m2

Note:
All dimensions are out to out.
D = pin diameter.

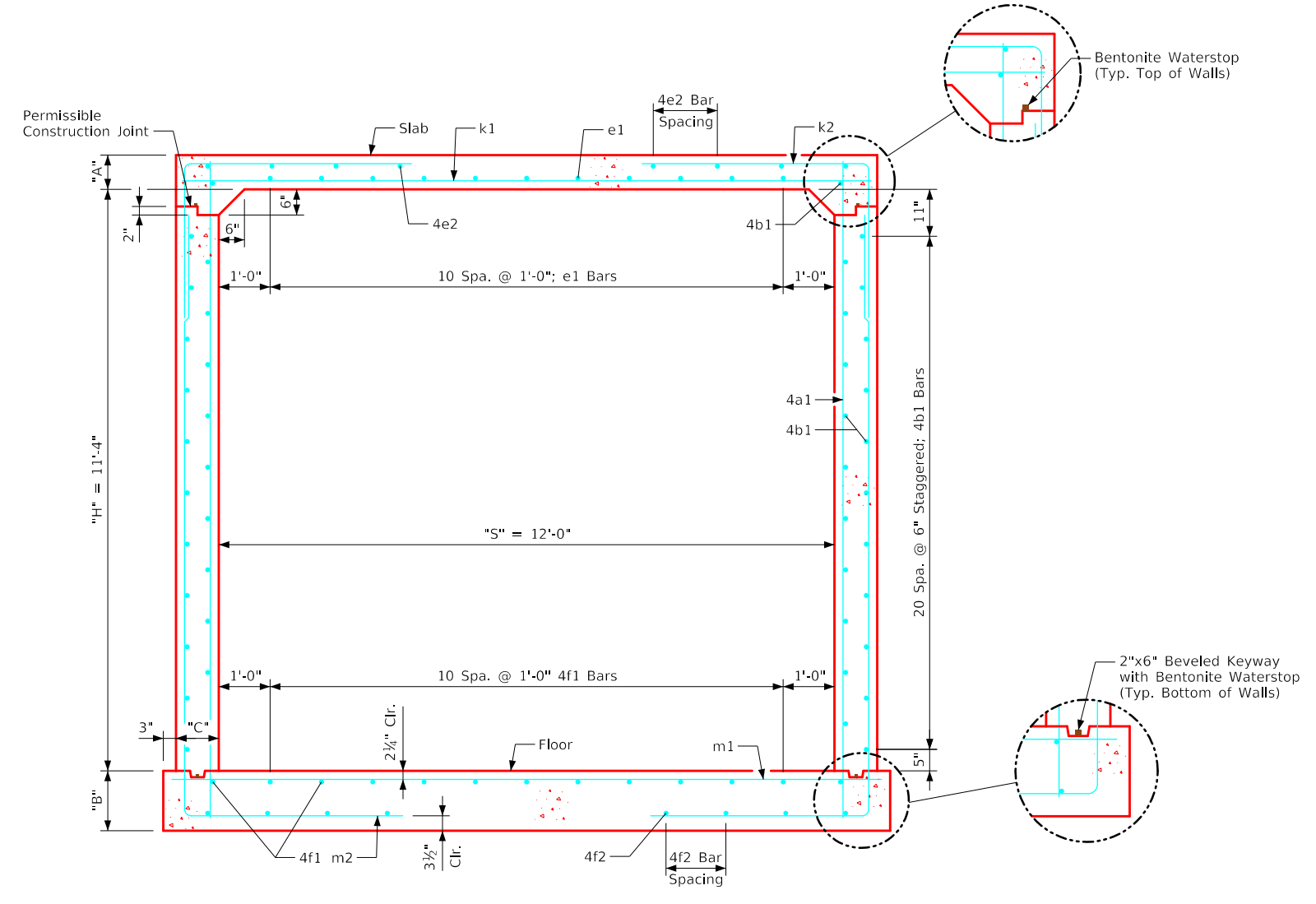

12'-0" x 11'-4" Barrel Section

- ### Notes:
- Dimensions listed on this sheet to be used in conjunction with Sheet PT G2-20.
 - Horizontal legs for the k2 and m2 bars may lap in low fill situations.
 - Dimensions "A", "B", "C", "D", and "Sp." listed in the bar list are in inches.
 - Dimensions "S", "H", "L", and "V" listed in the bar list are in feet and inches.

LATEST REVISION DATE	APPROVED BY BRIDGE ENGINEER	Cast-In-Place Standard Design - Walkways and Trails Reinforced Concrete Pedestrian Tunnel August, 2020
Tunnel Details 12'-0" x 11'-4"		PT-RCB 12-11-20

ENGLISH_LRFD_SIGNED_PEDESTRIAN_TUNNEL_STANDARDS.DGN - PT-RCB 12-11-20 - THIS SHEET ISSUED 08-2020

Variable Dimensions and Quantities for 12'-0" x 12'-4" Barrel Sections

Dimensions								Bar List																				Quantities																						
								a1		b1			e1			e2			f1			f2			k1				k2				k9			m1			m2			m9			Concrete (CY/FT)				Steel (LB/FT)	
Fill	S	H	A	B	C	D		Size	Sp.	L	Size	Sp.	No.	Size	Sp.	No.	Size	Sp.	No.	Size	Sp.	No.	Size	Sp.	L	Size	Sp.	L	H	V	Size	L	Size	Sp.	L	Size	Sp.	L	H	V	Size	L	Slab	Floor	Walls	Total				
0	12'-0"	12'-4"	13.5	15	12	9		4	9	14'-3"	4	6	48	5	12	11	4	16	10	4	12	13	4	16	10	8	12	13'-8"	6	9	12'-1"	8'-1"	4'-0"	--	--	7	9	14'-2"	6	9	20'-9"	8'-1"	12'-8"	--	--	0.623	0.667	0.887	2.177	307.92
1	12'-0"	12'-4"	12.5	14.5	12	9		4	9	14'-1"	4	6	48	5	12	11	4	16	10	4	12	13	4	16	10	7	9	13'-8"	6	9	12'-0"	8'-1"	3'-11"	--	--	7	9	14'-2"	6	9	20'-8"	8'-1"	12'-7"	--	--	0.580	0.645	0.887	2.112	306.53
2	12'-0"	12'-4"	8.5	10.5	12	9		4	9	13'-5"	4	6	48	5	12	11	4	16	10	4	12	13	4	18	8	8	9	13'-8"	7	9	11'-5"	7'-5"	4'-0"	--	--	7	6	14'-2"	7	9	17'-7"	5'-4"	12'-3"	7	14'-2"	0.407	0.466	0.887	1.760	364.21
3	12'-0"	12'-4"	8	10.5	12	9		4	9	13'-5"	4	6	48	4	12	11	4	17	8	4	12	13	4	16	8	8	9	13'-8"	6	6	8'-10"	5'-3"	3'-7"	6	13'-8"	6	6	14'-2"	6	6	17'-1"	4'-10"	12'-3"	6	14'-2"	0.386	0.466	0.887	1.739	336.29
4-6	12'-0"	12'-4"	8	10.5	12	9		4	9	13'-5"	4	6	48	4	12	11	4	16	8	4	12	13	4	15	8	6	6	13'-8"	6	6	8'-5"	4'-10"	3'-7"	6	13'-8"	7	6	14'-2"	6	6	16'-11"	4'-8"	12'-3"	6	14'-2"	0.386	0.466	0.887	1.739	339.03
7-9	12'-0"	12'-4"	8.5	11	12	9		4	9	13'-6"	4	6	48	4	12	11	4	14	8	4	12	13	4	14	8	7	6	13'-8"	6	6	7'-11"	4'-4"	3'-7"	6	13'-8"	7	6	14'-2"	6	6	16'-8"	4'-4"	12'-4"	6	14'-2"	0.407	0.488	0.887	1.782	349.61
10-12	12'-0"	12'-4"	9.5	12.5	12	9		4	9	13'-8"	4	6	48	4	12	11	4	13	8	4	12	13	4	13	8	7	6	13'-8"	6	6	7'-10"	4'-2"	3'-8"	6	13'-8"	7	6	14'-2"	6	6	16'-8"	4'-3"	12'-5"	6	14'-2"	0.451	0.555	0.887	1.893	349.39
13-15	12'-0"	12'-4"	10.5	13	12	9		4	12	13'-10"	4	6	48	4	12	11	4	18	6	4	12	13	4	18	6	7	6	13'-8"	6	6	7'-8"	3'-10"	3'-10"	6	13'-8"	8	6	14'-2"	6	6	16'-4"	3'-10"	12'-6"	6	14'-2"	0.494	0.578	0.887	1.959	356.16

Bent Bar Details

Bars	D
6	4 1/2"
7	5 1/4"

k2 & m2

Note:
All dimensions are out to out.
D = pin diameter.

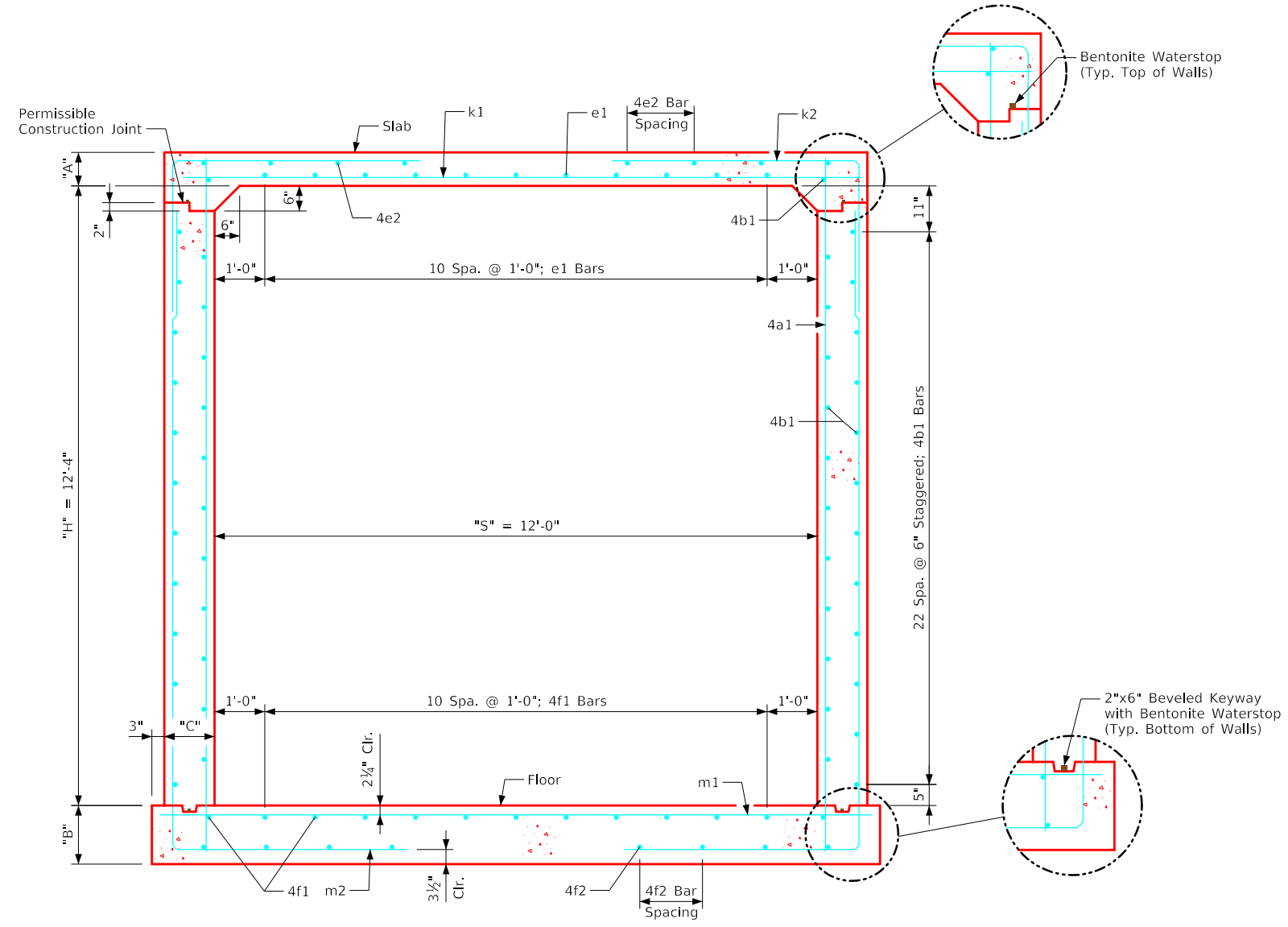

- ### Notes:
- Dimensions listed on this sheet to be used in conjunction with Sheet PT G2-20.
 - Horizontal legs for the k2 and m2 bars may lap in low fill situations.
 - Dimensions "A", "B", "C", "D", and "Sp." listed in the bar list are in inches.
 - Dimensions "S", "H", "L", and "V" listed in the bar list are in feet and inches.

LATEST REVISION DATE	APPROVED BY BRIDGE ENGINEER	Cast-In-Place Standard Design - Walkways and Trails Reinforced Concrete Pedestrian Tunnel August, 2020	
		Tunnel Details 12'-0" x 12'-4"	PT-RCB 12-12-20

ENGLISH_LRFD_SIGNED_PEDESTRIAN_TUNNEL_STANDARDS.DGN - PT-RCB 12-12-20 - THIS SHEET ISSUED 08-2020

Variable Dimensions and Quantities for 14'-0" x 12'-4" Barrel Sections

Fill		Dimensions							Bar List																											Quantities																		
		S	H	A	B	C	D		a1			b1			e1			e2			f1			f2			k1			k2						k9			m1			m2						m9				Concrete (CY/FT)		
0	1	2	3	4-6	7-9	10-12	13-15	Size	Sp.	L	Size	Sp.	No.	Size	Sp.	No.	Size	Sp.	No.	Size	Sp.	No.	Size	Sp.	No.	Size	Sp.	No.	Size	Sp.	No.	Size	Sp.	No.	Size	Sp.	No.	Size	Sp.	No.	Size	Sp.	No.	Slab	Floor	Walls	Total							
0	14'-0"	12'-4"	14	15.5	12	9	6	9	14'-4"	4	6	48	5	12	13	4	15	12	4	12	15	4	15	12	7	9	15'-8"	6	9	13'-2"	9'-1"	4'-1"	--	---	7	9	16'-2"	6	9	20'-1"	7'-5"	12'-8"	6	16'-2"	0.731	0.760	0.887	2.403	360.18					
1	14'-0"	12'-4"	13.5	15	12	9	5	9	14'-3"	4	6	48	5	12	13	4	15	12	4	12	15	4	15	12	7	9	15'-8"	6	9	13'-1"	9'-1"	4'-0"	--	---	7	9	16'-2"	6	9	20'-5"	7'-9"	12'-8"	6	16'-2"	0.707	0.760	0.887	2.354	343.34					
2	14'-0"	12'-4"	9	11	12	9	4	12	13'-6"	4	6	48	6	12	13	4	15	10	4	12	15	4	13	10	7	6	15'-8"	6	6	9'-8"	6'-1"	3'-7"	6	15'-8"	7	6	16'-2"	6	6	17'-9"	5'-5"	12'-4"	6	16'-2"	0.485	0.556	0.887	1.928	394.08					
3	14'-0"	12'-4"	8.5	10.5	12	9	4	12	13'-5"	4	6	48	4	12	13	4	13	10	4	12	15	4	17	8	7	6	15'-8"	8	9	9'-9"	5'-5"	4'-4"	8	15'-8"	7	6	16'-2"	8	9	17'-4"	5'-1"	12'-3"	8	16'-2"	0.460	0.531	0.887	1.878	418.66					
4-6	14'-0"	12'-4"	8.5	11	12	9	4	12	13'-6"	4	6	48	4	12	13	4	16	8	4	12	15	4	16	8	7	6	15'-8"	7	6	8'-10"	4'-11"	3'-11"	7	15'-8"	7	6	16'-2"	7	6	17'-2"	4'-10"	12'-4"	7	16'-2"	0.460	0.556	0.887	1.903	430.05					
7-9	14'-0"	12'-4"	10	12.5	12	9	4	12	13'-9"	4	6	48	4	12	13	4	15	8	4	12	15	4	15	8	7	6	15'-8"	6	6	8'-4"	4'-7"	3'-9"	6	15'-8"	8	6	16'-2"	6	6	17'-0"	4'-7"	12'-5"	6	16'-2"	0.534	0.633	0.887	2.054	388.84					
10-12	14'-0"	12'-4"	11	13.5	12	6	4	6	13'-11"	4	6	48	4	12	13	4	13	8	4	12	15	4	13	8	8	6	15'-8"	7	6	8'-6"	4'-3"	4'-3"	7	15'-8"	8	6	16'-2"	6	6	16'-9"	4'-3"	12'-6"	6	16'-2"	0.583	0.683	0.887	2.153	445.66					
13-15	14'-0"	12'-4"	12	14.5	12.5	6	4	6	14'-1"	4	6	48	4	12	13	4	13	8	4	12	15	4	13	8	8	6	15'-9"	6	6	8'-4"	4'-2"	4'-2"	6	15'-9"	8	6	16'-3"	6	6	16'-9"	4'-2"	12'-7"	6	16'-3"	0.637	0.738	0.924	2.299	426.87					

Bent Bar Details

Bars	D
6	4 1/2"
7	5 1/4"
8	6"

k2 & m2

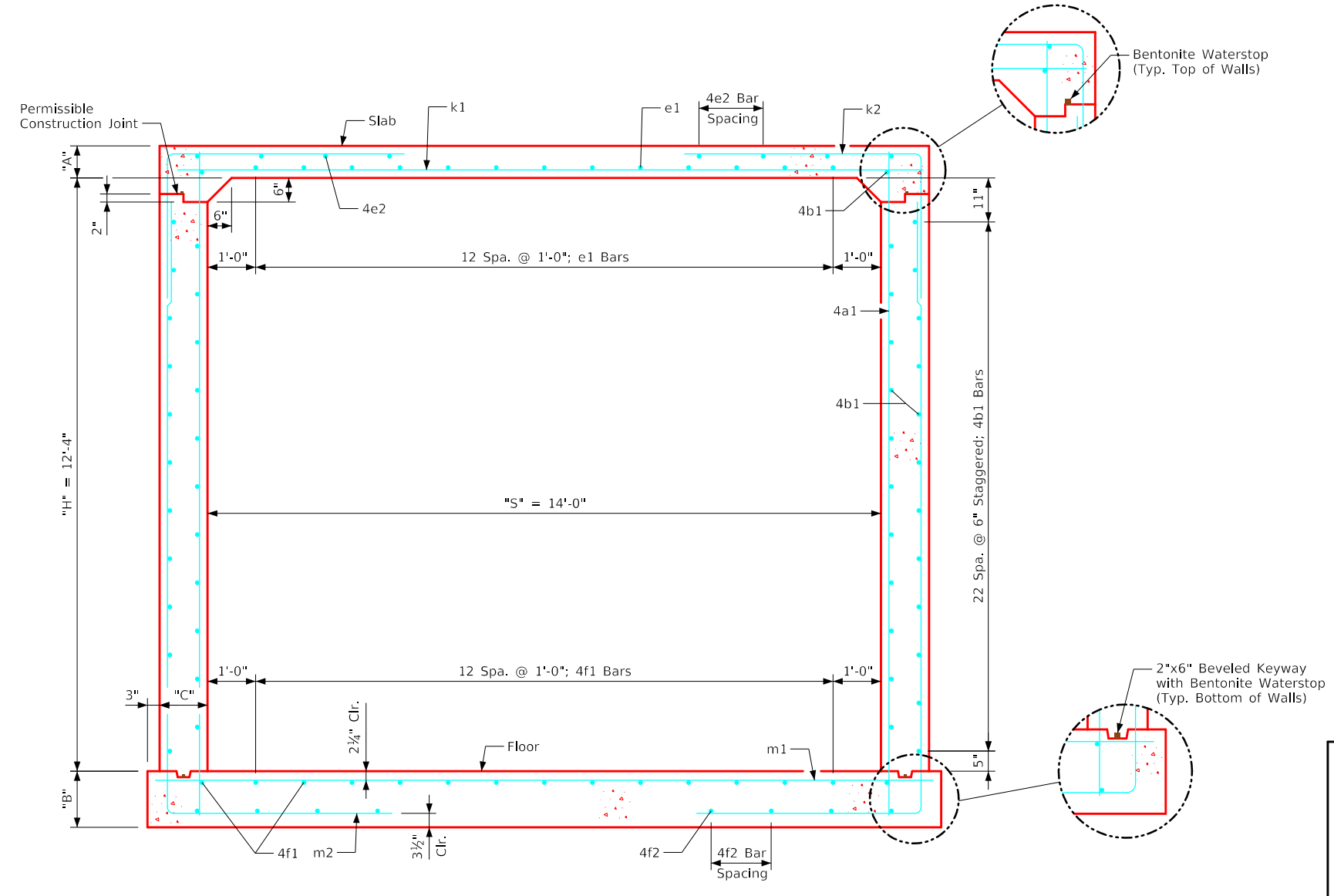

14'-0" x 12'-4" Barrel Section

- ### Notes:
- Dimensions listed on this sheet to be used in conjunction with Sheet PT G2-20.
 - Horizontal legs for the k2 and m2 bars may lap in low fill situations.
 - Dimensions "A", "B", "C", "D", and "Sp." listed in the bar list are in inches.
 - Dimensions "S", "H", "L", and "V" listed in the bar list are in feet and inches.

LATEST REVISION DATE	 APPROVED BY BRIDGE ENGINEER		
		Cast-In-Place Standard Design - Walkways and Trails Reinforced Concrete Pedestrian Tunnel August, 2020	
		Tunnel Details 14'-0" x 12'-4"	PT-RCB 14-12-20

ENGLISH_LRFD_SIGNED_PEDESTRIAN_TUNNEL_STANDARDS.DGN - PT-RCB 14-12-20 - THIS SHEET ISSUED 08-2020

ENGLISH_LRFD_SIGNED_PEDESTRIAN_TUNNEL_STANDARDS.DGN - PT-FWH 0-1-20 - THIS SHEET ISSUED 08-2020

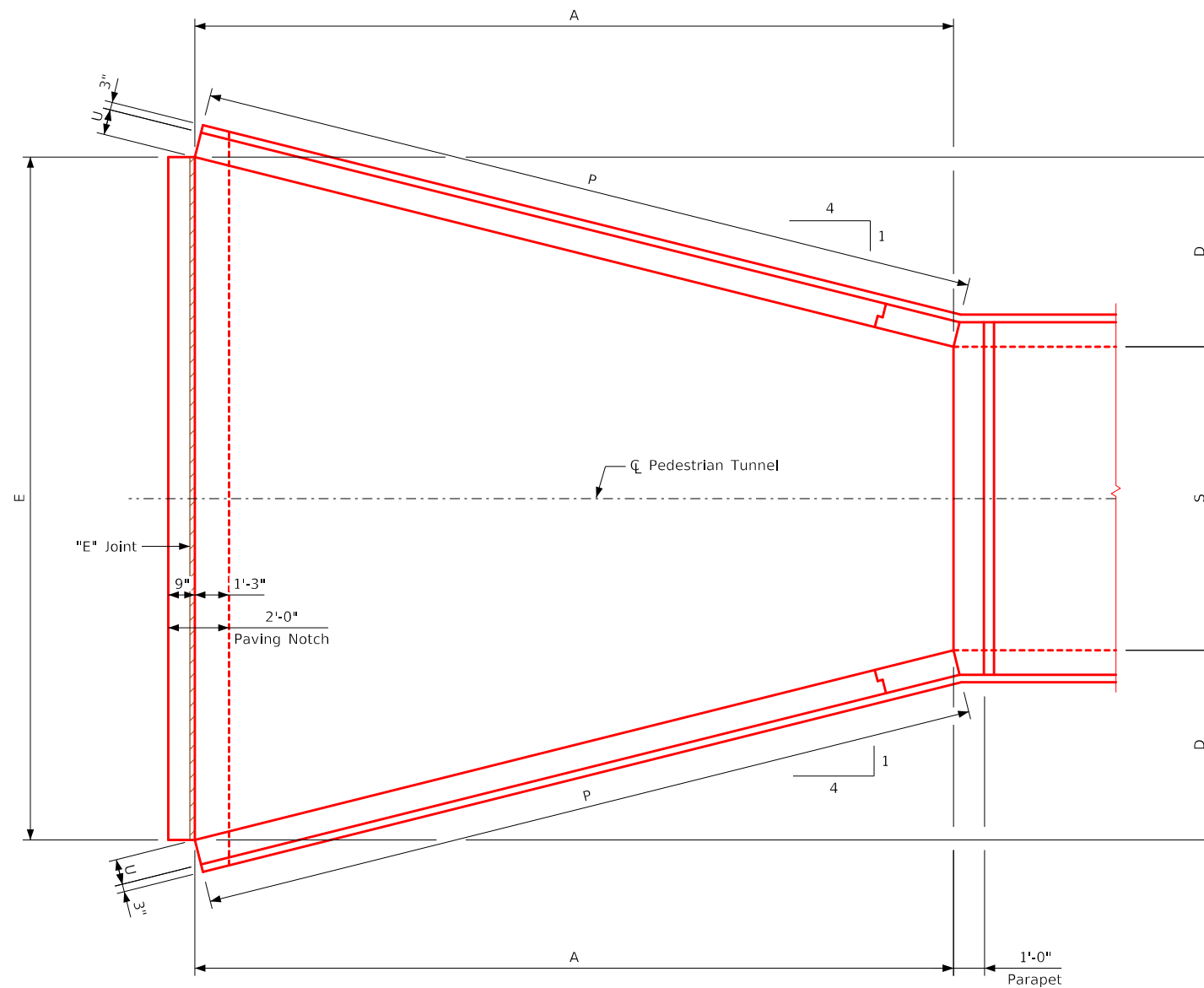

Dimension Table			
S x H	14' x 12'-4"	12' x 12'-4"	12' x 11'-4"
A	37'-0"	37'-0"	34'-0"
D	9'-3"	9'-3"	8'-6"
E	32'-6"	30'-6"	29'-0"
G1	32'-6"	30'-6"	29'-0"
G2	34'-5 $\frac{3}{8}$ "	32'-5 $\frac{3}{8}$ "	30'-9 $\frac{3}{8}$ "
G3	11 $\frac{3}{4}$ "	11 $\frac{3}{4}$ "	1'-0"
P	38'-1 $\frac{5}{8}$ "	38'-1 $\frac{5}{8}$ "	35'-0 $\frac{1}{2}$ "
R	40'-1"	40'-1"	36'-10"
T	1'-2"	1'-2"	1'-2"
U	1'-0"	1'-0"	11"



Plan View

Notes:

1. See Sheet PT G1-20 for General Information, Specifications, and Design Stresses.
2. See Sheets PT-FWH 0-2-20 & PT-FWH 0-3-20 for location of certain dimensions tabulated.

LATEST REVISION DATE	 APPROVED BY BRIDGE ENGINEER		
		Cast-In-Place Standard Design - Walkways and Trails Reinforced Concrete Pedestrian Tunnel August, 2020	
		Flared Wing Headwalls 0° SKEW	PT-FWH 0-1-20

ENGLISH_LRFD_SIGNED_PEDESTRIAN_TUNNEL_STANDARDS.DGN - PT-FWH 0-2-20 - THIS SHEET ISSUED 08-2020

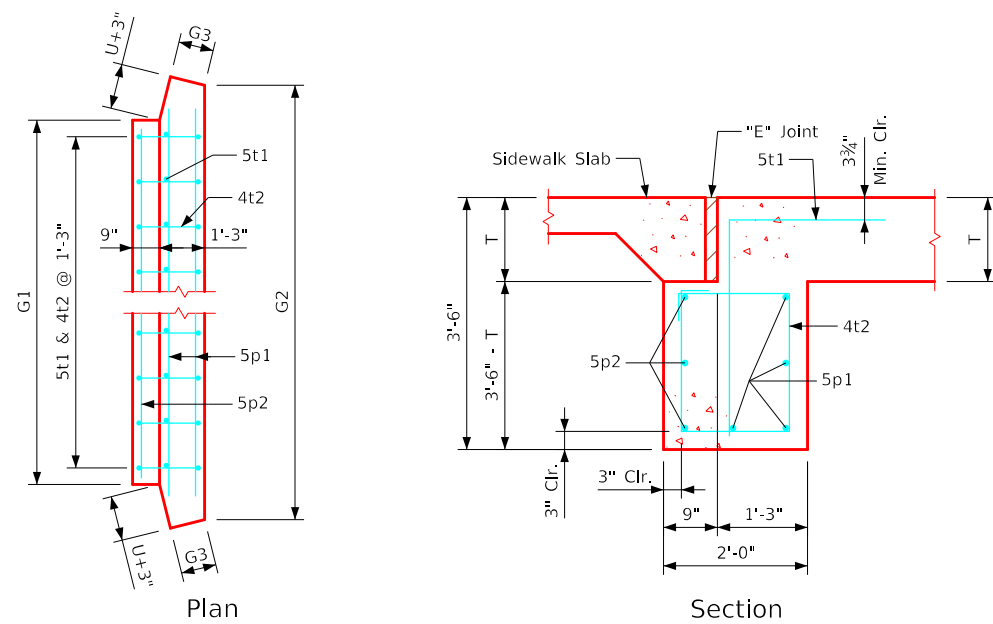

Paving Notch Details

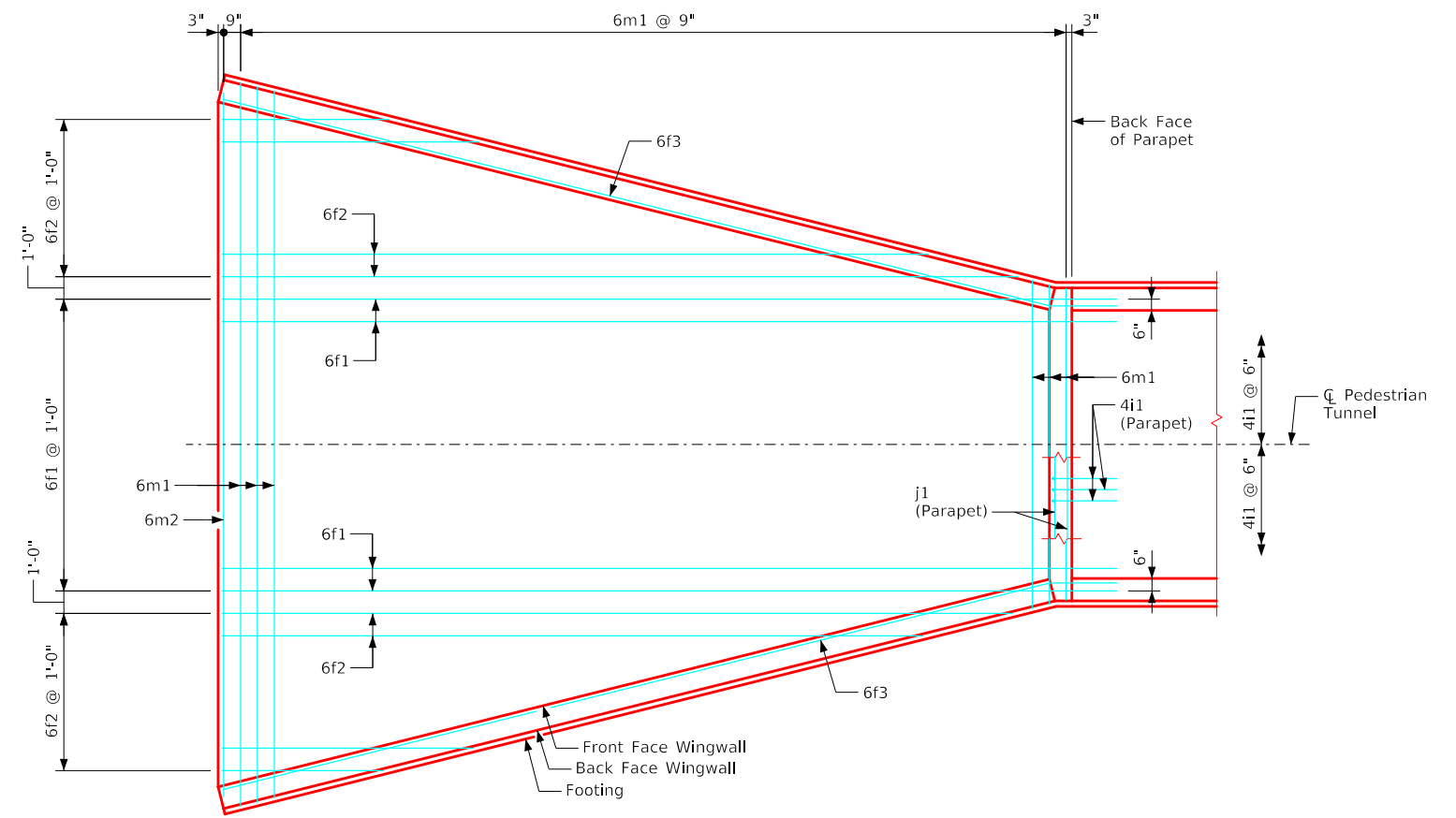

Plan View - Top of Apron Reinforcing Bars
(Paving Notch Not Shown for Clarity)

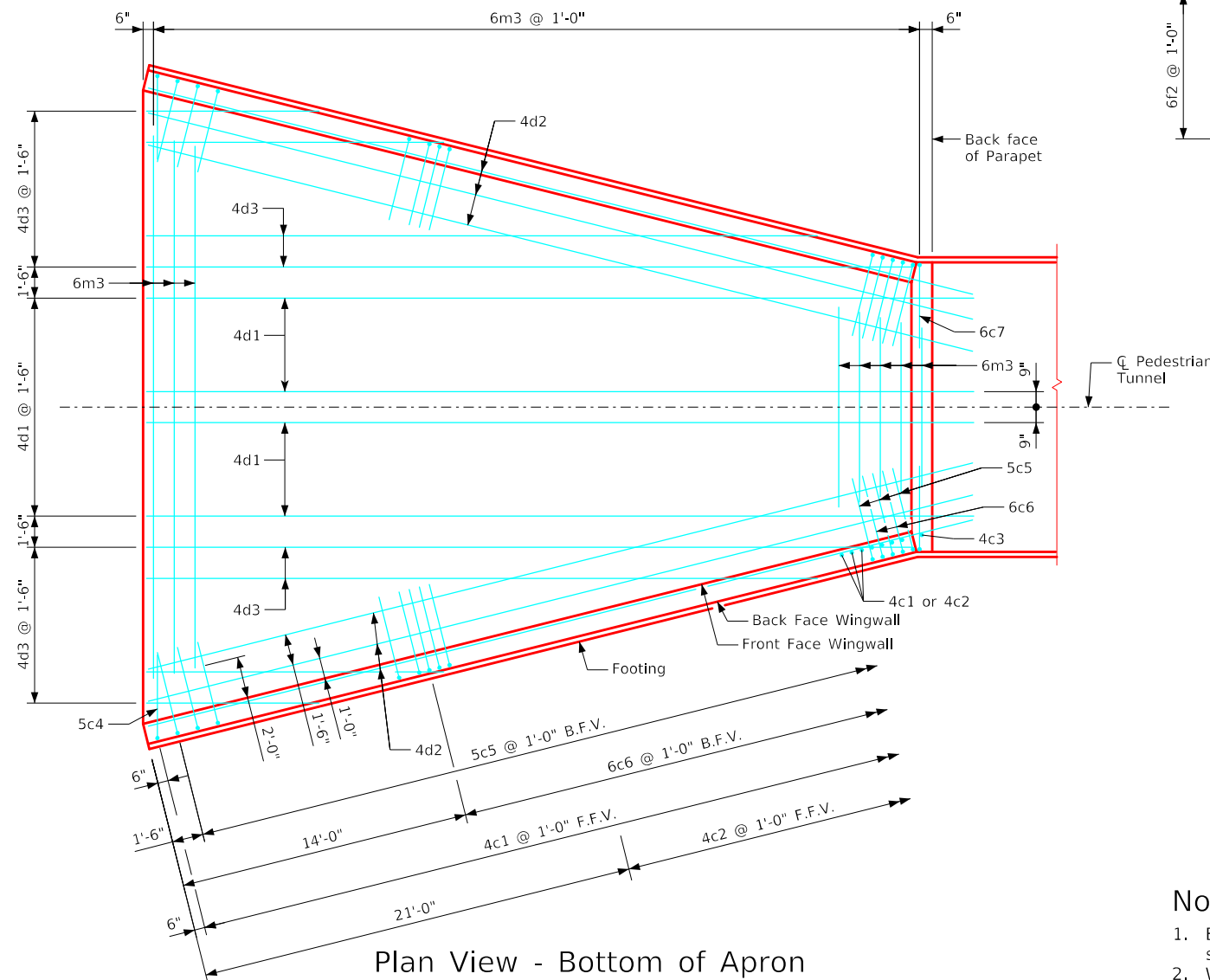

Plan View - Bottom of Apron Reinforcing Bars
(Paving Notch Not Shown for Clarity)

S x H	Quantity (CY)
14' x 12'-4"	9.8
12' x 12'-4"	9.3
12' x 11'-4"	8.9

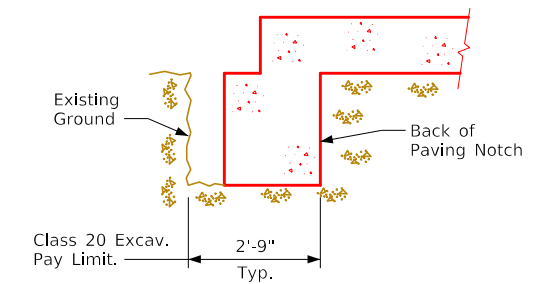

Class 20 Excavation for Paving Notch



Paving Notch Class 20 Excavation

Notes:

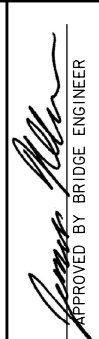
1. Bar spacings and positions shown are similar for all sizes of headwalls in this standard.
2. Wingwall bars consistently referenced from end of wing for all headwalls.
3. For dimension table see Sheet PT-FWH 0-1-20.

LATEST REVISION DATE	 APPROVED BY BRIDGE ENGINEER		
		Cast-In-Place Standard Design - Walkways and Trails Reinforced Concrete Pedestrian Tunnel August, 2020	
		Flared Wing Headwalls 0° SKEW	PT-FWH 0-2-20

ENGLISH_LRFD_SIGNED_PEDESTRIAN_TUNNEL_STANDARDS.DGN - PT-FWH 0-3-20 - THIS SHEET ISSUED 08-2020

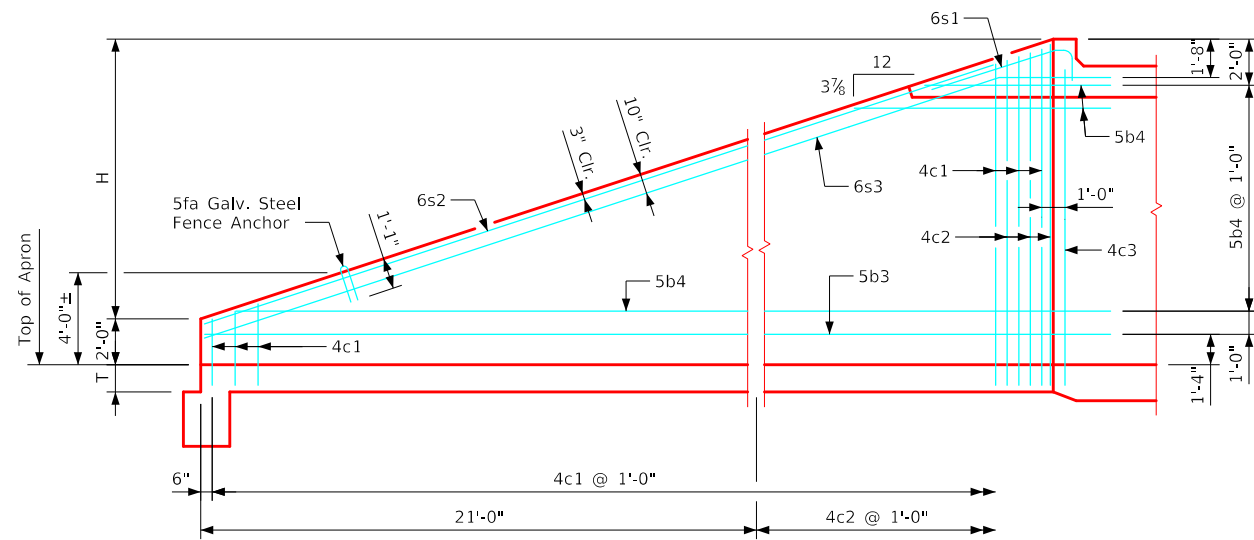

Typical View - Front Face Reinforcing

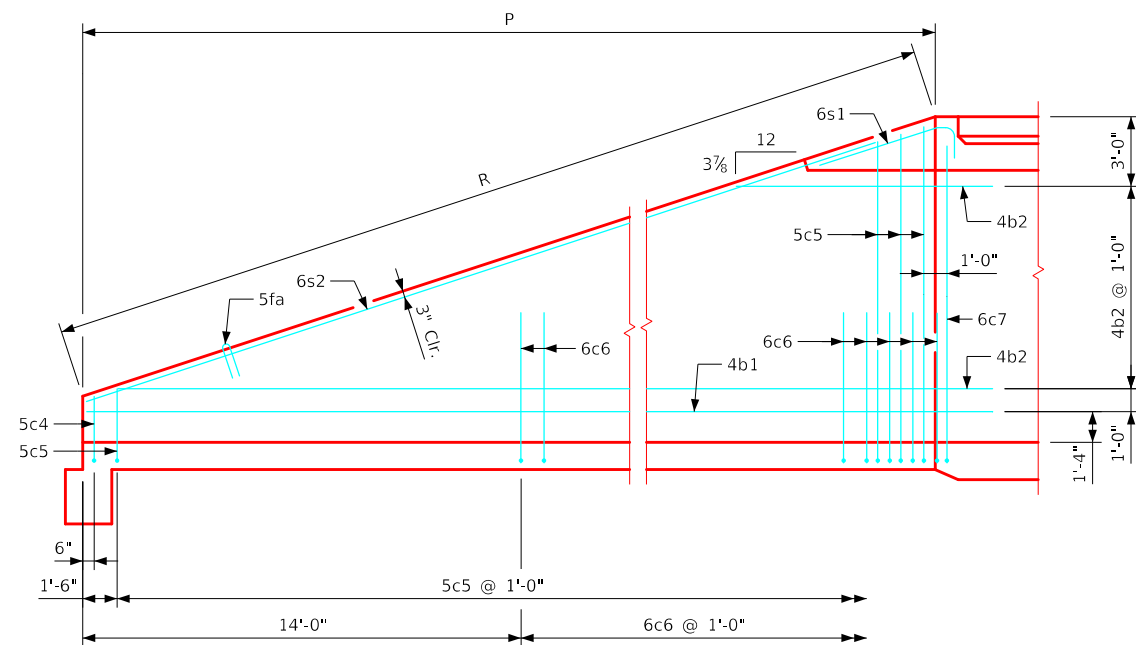

Typical View - Back Face Reinforcing

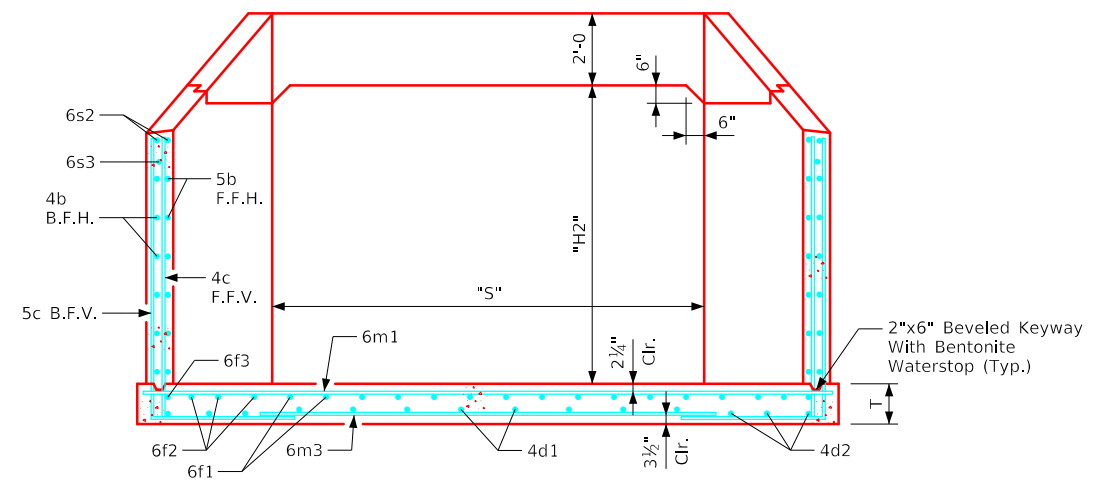

Typical Section - Near Center of Apron

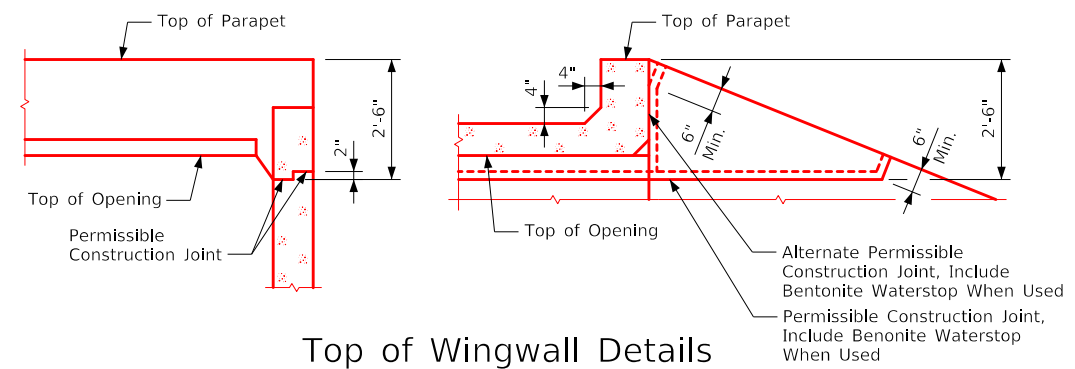

Top of Wingwall Details

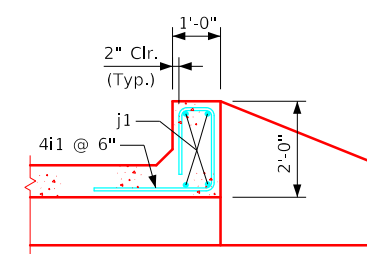

Section thru Parapet

Notes:

1. Bar spacing and positions shown are similar for all sizes of headwall in this standard.
2. For dimension table see Sheet PT-FWH 0-1-20.

LATEST REVISION DATE	APPROVED BY BRIDGE ENGINEER	Cast-In-Place Standard Design - Walkways and Trails Reinforced Concrete Pedestrian Tunnel August, 2020	
		Flared Wing Headwalls 0° Skew	PT-FWH 0-3-20

Reinforcing for One Headwall 0° Skew													
Location	Shape	14' x 12'-4"				12' x 12'-4"				12' x 11'-4"			
		Bar	No.	Length	Wt.	Bar	No.	Length	Wt.	Bar	No.	Length	Wt.
Fence Anchor (Galv.)		5fa	2	2'-10"	6	5fa	2	2'-10"	6	5fa	2	2'-10"	6
Wingwall, B.F.H.		4b1	2	41'-2"	58	4b1	2	41'-2"	58	4b1	2	38'-1"	51
Wingwall, B.F.H.		4b2	20 Var.	2 Each 11'-11" to 39'-9"	345	4b2	20 Var.	2 Each 11'-11" to 39'-9"	345	4b2	18 Var.	2 Each 11'-11" to 36'-8"	292
Wingwall, F.F.H.		5b3	2	41'-3"	91	5b3	2	41'-3"	91	5b3	2	38'-2"	80
Wingwall, F.F.H.		5b4	22 Var.	2 Each 8'-10" to 39'-10"	558	5b4	22 Var.	2 Each 8'-10" to 39'-10"	558	5b4	20 Var.	2 Each 8'-10" to 36'-9"	475
Wingwall, F.F.V.		4c1	76 Var.	2 Each 2'-10" to 14'-10"	448	4c1	76 Var.	2 Each 2'-10" to 14'-10"	448	4c1	70 Var.	2 Each 2'-10" to 13'-10"	390
Wingwall, F.F.V.		4c2	36 Var.	2 Each 9'-6" to 15'-0"	295	4c2	36 Var.	2 Each 9'-6" to 15'-0"	295	4c2	30 Var.	2 Each 9'-6" to 14'-0"	235
Wingwall, F.F.V.		4c3	2	13'-9"	18	4c3	2	13'-9"	18	4c3	2	5'-2"	17
Wingwall, B.F.V.		5c4	2	5'-2"	11	5c4	2	5'-2"	11	5c4	2	5'-2"	11
Wingwall, B.F.V.		5c5	74 Var.	2 Each 7'-2" to 18'-10"	1003	5c5	74 Var.	2 Each 7'-2" to 18'-10"	1003	5c5	68 Var.	2 Each 7'-2" to 17'-10"	887
Wingwall, B.F.V.		6c6	50	10'-6"	789	6c5	50	10'-6"	789	6c6	44	10'-6"	694
Wingwall, B.F.V.		6c7	2	17'-9"	53	6c7	2	17'-9"	53	6c7	2	16'-9"	50
Apron, Longit., Bott.		4d1	10	40'-3"	285	4d1	8	40'-3"	228	4d1	8	40'-3"	199
Apron, Longit., Bott.		4d2	6	41'-5"	176	4d2	6	41'-5"	176	4d2	6	38'-4"	154
Apron, Longit., Bott.		4d3	12 Var.	2 Each 6'-2" to 36'-2"	170	4d3	12 Var.	2 Each 8'-2" to 38'-2"	186	4d3	12 Var.	2 Each 4'-10" to 34'-10"	159
Apron, Longit., Top		6f1	16	40'-3"	1025	6f1	14	40'-3"	897	6f1	14	37'-3"	783
Apron, Longit., Top		6f2	16 Var.	2 Each 7'-2" to 35'-2"	509	6f2	16 Var.	2 Each 7'-2" to 35'-2"	509	6f2	14 Var.	2 Each 7'-10" to 31'-10"	417
Apron, Longit., Top		6f3	2	40'-11"	130	6f3	2	40'-11"	130	6f3	2	37'-10"	114
Parapet, Vertical		4i1	29	6'-1"	118	4i1	25	6'-1"	102	4i1	25	6'-1"	102
Parapet, Horizontal		7ji	4	15'-8"	213	7ji	4	13'-8"	112	7ji	4	13'-6"	110
Apron, Trans., Top		6m1	50 Var.	15'-10" to 34'-2"	1878	6m1	50 Var.	13'-10" to 32'-2"	1727	6m1	46 Var.	13'-8" to 30'-6"	1526
Apron, Trans., Top		6m2	1	32'-10"	49	6m2	1	30'-10"	46	6m2	1	29'-4"	44
Apron, Trans., Bott.		6m3	38 Var.	9'-7" to 28'-1"	1075	6m3	38 Var.	7'-7" to 26'-1"	961	6m3	35 Var.	7'-7" to 24'-7"	846
Paving Notch, Horizontal		5p1	4	32'-10"	137	5p1	4	30'-10"	129	5p1	4	29'-4"	122
Paving Notch, Horizontal		5p2	3	32'-2"	101	5p2	3	30'-2"	94	5p2	3	28'-8"	90
Wing Slope, Both F.		6s1	4	7'-8"	46	6s1	4	7'-8"	46	6s1	4	7'-8"	46
Wing Slope, Both F.		6s2	4	37'-6"	225	6s2	4	37'-6"	225	6s2	4	34'-3"	206
Wing Slope, F.F.		6s3	2	43'-2"	137	6s3	2	43'-2"	137	6s3	2	39'-11"	120
Paving Notch, Vertical		5t1	26	5'-2"	140	5t1	25	5'-2"	135	5t1	23	5'-2"	124
Paving Notch, Hoops		4t2	26	7'-7"	132	4t2	25	7'-7"	127	4t2	23	7'-7"	117
Estimated Quantities One Headwall	Reinf. Steel	10,221 LB				9642 LB				8467 LB			
	Concrete	Parapet Δ	1.9			1.8				1.7			
		Wingwalls	23.2	72.9 CY		23.2	69.2 CY			18.3	59.5 CY		
		Apron *	47.8			44.2				39.5			

Notes:
 Weight of bars over 40'-0" long includes an allowance of 2'-5" for lap.
 Lengths shown for bars over 40'-0" long do not include lap.

Δ Includes top of wingwall quantities.
 * Assumes apron and floor are equal thickness, adjust concrete quantities for transition where apron and floor thickness are not equal.

Headwall Notes:

- See Sheet PT G1-20 for General Information, Specifications, and Design Stresses.
- This headwall is based on a 3:1 slope normal to centerline of roadway.
- The sides of the apron are to be formed to ensure correct line and grade.
- All slab and apron reinforcing steel is to be supported by bar chairs at intervals of not more than 3'-0" in either direction as outlined in the Standard Specifications.
- Clear distance from face of concrete to near reinforcing bar is to be 2" unless otherwise noted or shown. Clearance to the bottom ends of vertical bars shall be 3 inches.
- Concrete quantities are estimated from back of parapet.
- Horizontal tails of bars "b" & "s" estimated to extend 2'-5" beyond back of parapet (into end of barrel). Longitudinal bars "d" and "f" estimated to project into end section of barrel a minimum of 2'-5" beyond back of parapet. The "Length" column reflects total number of feet necessary to meet these requirements.
- Dimensions are in feet and inches unless otherwise noted or shown.

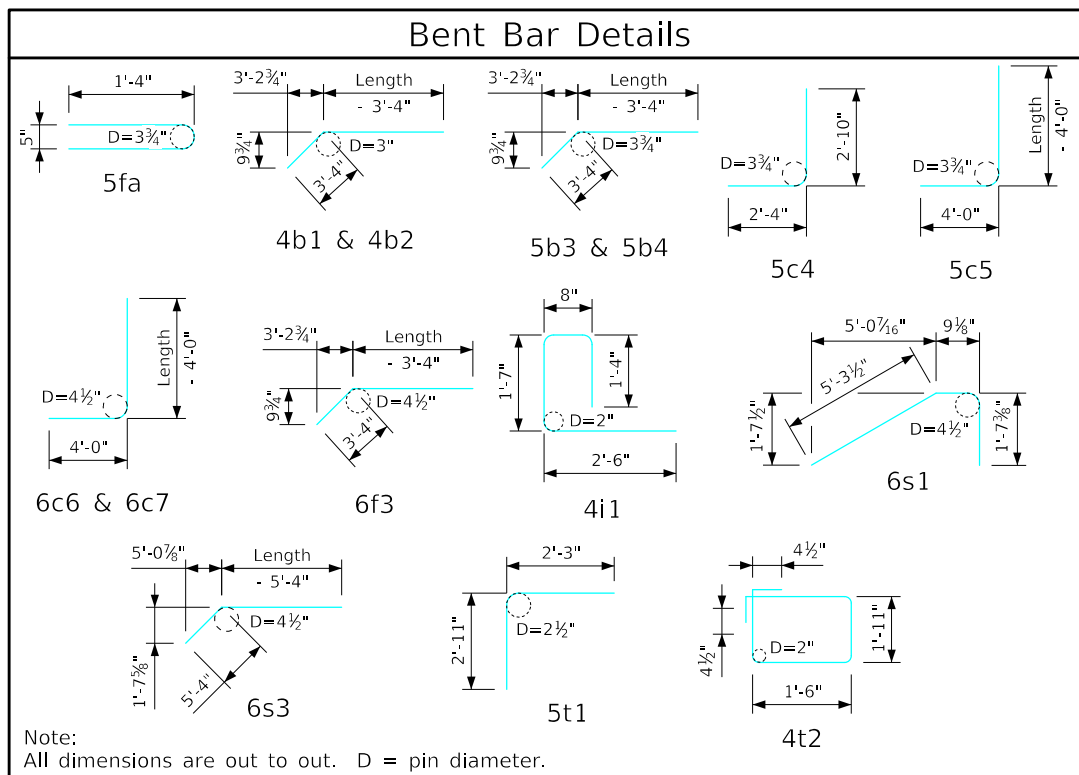

LATEST REVISION DATE	APPROVED BY BRIDGE ENGINEER	IOWA DOT Highway Division	
		Cast-In-Place Standard Design - Walkways and Trails	
		Reinforced Concrete Pedestrian Tunnel August, 2020	
		Flared Wing Headwalls 0° Skew	PT-FWH 0-4-20

ENGLISH_LRFD_SIGNED_PEDESTRIAN_TUNNEL_STANDARDS.DGN - PT-CBJ 1-20 - THIS SHEET ISSUED 08-2020

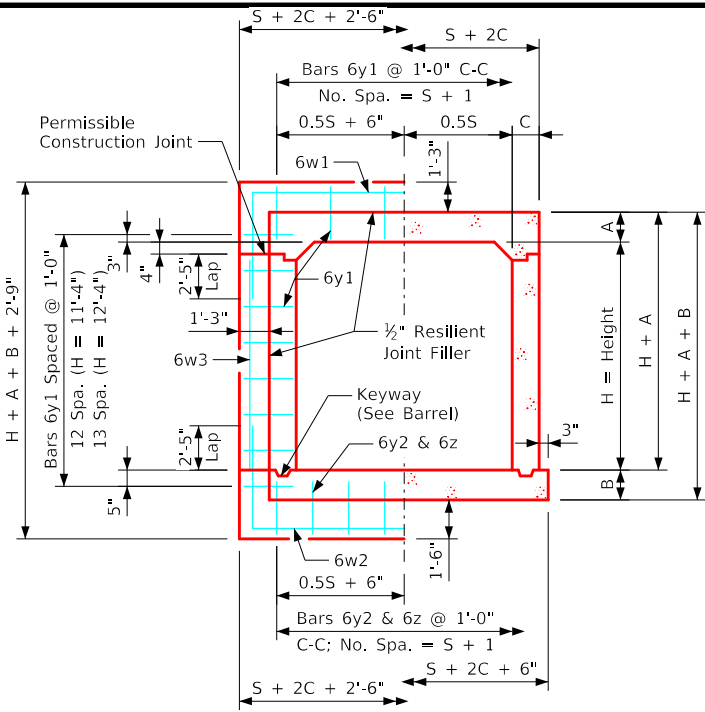

Joint Detail Section Thru Barrel

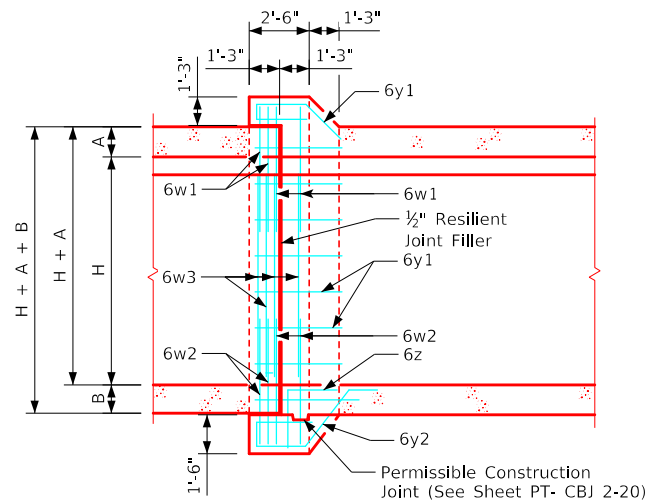

Longitudinal Section

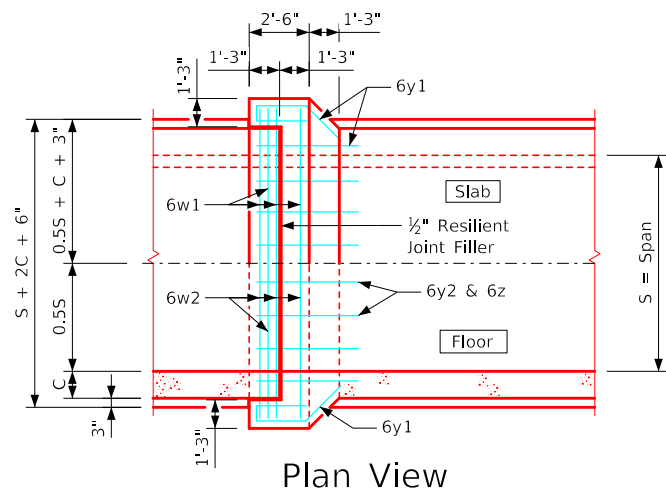

Plan View

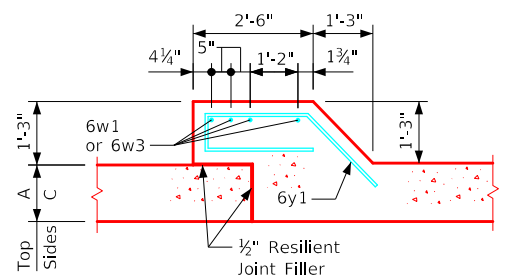

Top & Sides - Bars 6y1

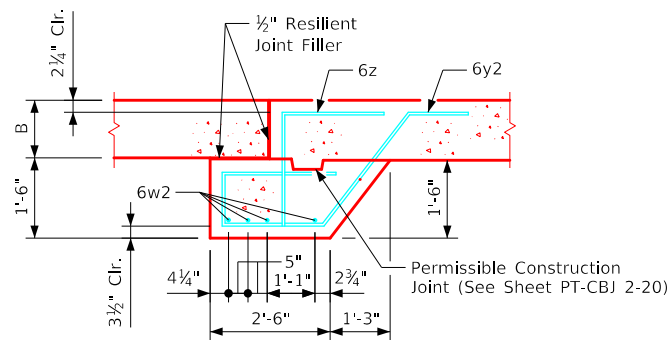

Bottom - Bars 6y2 & 6z

Barrel Size	Barrel Dimension			Bell Joint Quantities (CY)		
	A	B	C	Footing	Walls	Slab
12' x 11'-4"	10.5"	13"	11"	3.089	3.140	2.652
12' x 12'-4"	10.5"	13"	12"	3.118	3.426	2.677
14' x 12'-4"	12"	14.5"	12"	3.497	3.426	3.002

Concrete Placement

Est. of Quantities - One Joint											
Bill of Reinforcing Steel			14' x 12'-4"		12' x 12'-4"		12' x 11'-4"				
Bar	Location	Shape	No.	Length	Weight	No.	Length	Weight	No.	Length	Weight
6w1	Slab & Walls		4	28'-0"	168	4	26'-0"	156	4	25'-10"	155
6w2	Floor & Walls		4	27'-8"	166	4	25'-8"	154	4	25'-6"	153
6w3	Walls		8	11'-10"	142	8	11'-10"	142	8	10'-10"	130
6y1	Top & Sides		44	8'-0"	529	42	8'-0"	505	40	8'-0"	481
6y2	Bottom		16	9'-6"	228	14	9'-4"	196	14	9'-4"	196
6z	Bottom & Floor		16	3'-10"	92	14	3'-10"	81	14	3'-10"	81
Total Weight (LB)					1325	1234		1196			
Total Concrete (CY)					9.9	9.2		8.9			

Est. of Quantities - One Joint

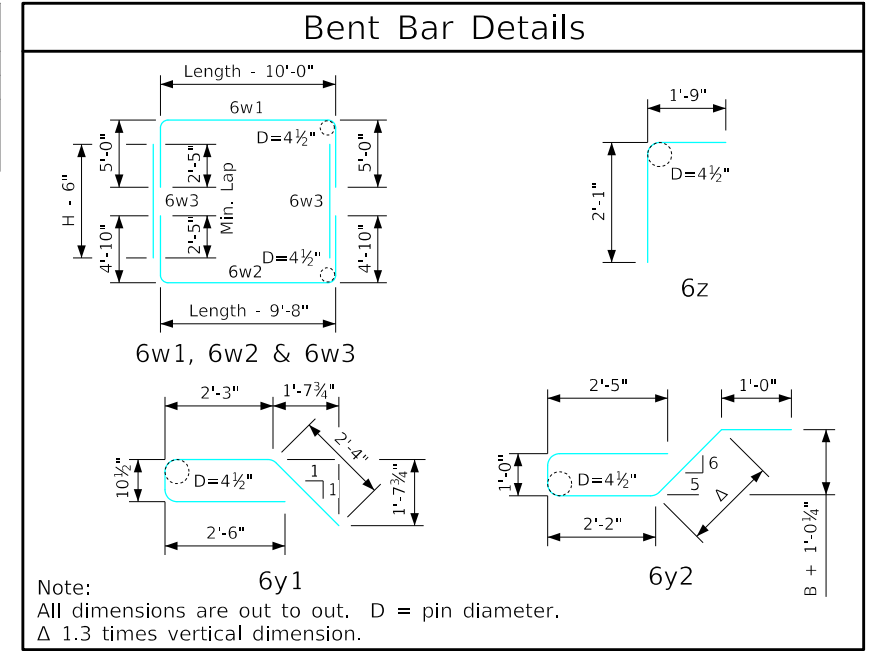

Bent Bar Details

Note:
All dimensions are out to out. D = pin diameter.
Δ 1.3 times vertical dimension.

Notes:

1. Dimensions and quantities shown are based on slab, floor, and wall thicknesses (A, B, and C, respectively). Values for these dimensions, under varying fill conditions, can be found on the reinforced concrete pedestrian tunnel detail sheets.
2. Change lengths of bars 6w1, 6w2, 6z, and adjust reinforcing steel and concrete quantities accordingly for slab, wall, and floor thicknesses other than shown.
3. All bar lengths are estimated with a 2" clearance from concrete edge to outside of bar, except as noted.
4. Material and construction to be in accordance with the current Standard Specifications of I.D.O.T.
5. See Sheet PT-RCB G1-20 for General Information, Specifications, and Design Stresses.
6. Barrel floor bars m1 & m9 are to be shortened 6" in length at bell joints.

LATEST REVISION DATE	 APPROVED BY BRIDGE ENGINEER	 Cast-In-Place Standard Design - Walkways and Trails Reinforced Concrete Pedestrian Tunnel August, 2020	
		Pedestrian Tunnel Bell Joints	PT-CBJ 1-20

ENGLISH_LRFD_SIGNED_PEDESTRIAN_TUNNEL_STANDARDS.DGN - PT-CBJ 2-20 - THIS SHEET ISSUED 08-2020

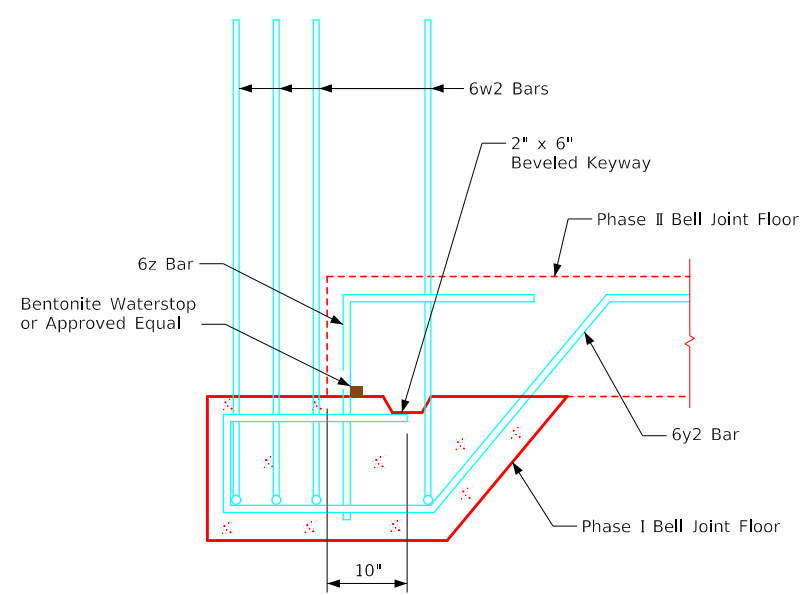

SECTION A-A
BELL JOINT AT FLOOR

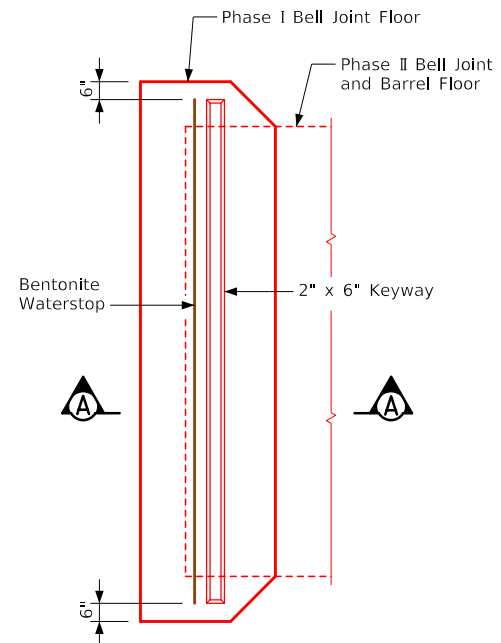

PLAN VIEW - PHASE I
(Showing Phase I of Floor Bell Joint Construction)

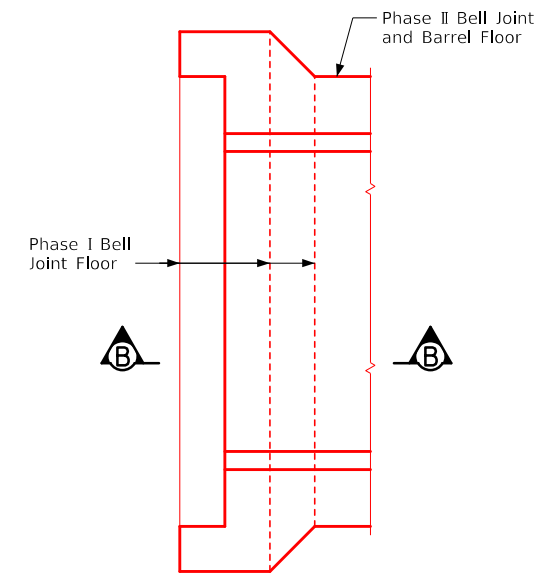

PLAN VIEW - PHASE II
(Showing Phase II of Floor Bell Joint and Barrel Floor Construction)

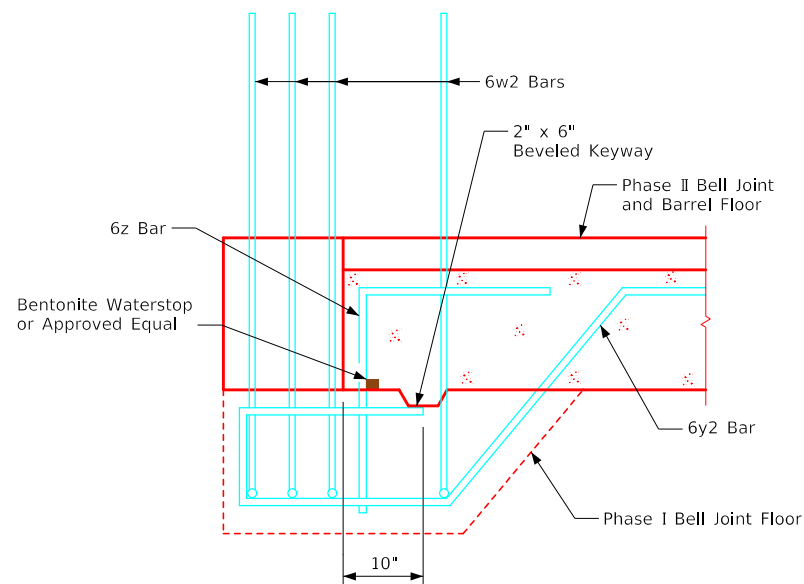

SECTION B-B
BELL JOINT AT FLOOR

NOTES:

1. The details shown on this sheet are an option for the contractor to construct the floor of the bell joint with a permissible construction joint as shown.
2. Reinforcing steel will be placed prior to placing the Phase I concrete.
3. The cost of the waterstop is considered incidental to the project.
4. A 2" x 6" beveled keyway will be formed to the distance shown and location noted before placing the concrete.
5. For details and dimensions of the bell joint refer to Sheet PT-CBJ 1-20.

LATEST REVISION DATE	 APPROVED BY BRIDGE ENGINEER		
		Cast-In-Place Standard Design - Walkways and Trails Reinforced Concrete Pedestrian Tunnel August, 2020	
		Pedestrian Tunnel Bell Joints	PT-CBJ 2-20

ENGLISH_LRFD_SIGNED_PEDESTRIAN_TUNNEL_STANDARDS.DGN - PT-SR 1-20 - THIS SHEET ISSUED 08-2020

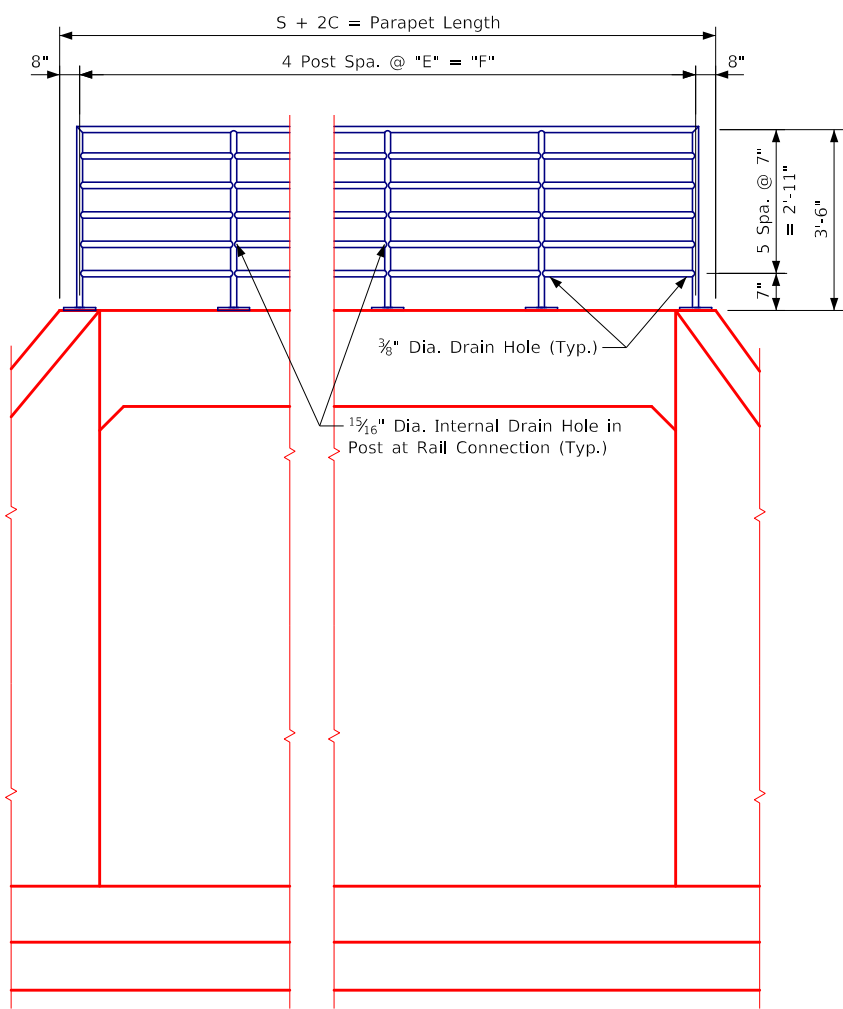

Partial End View of Parapet and Headwall

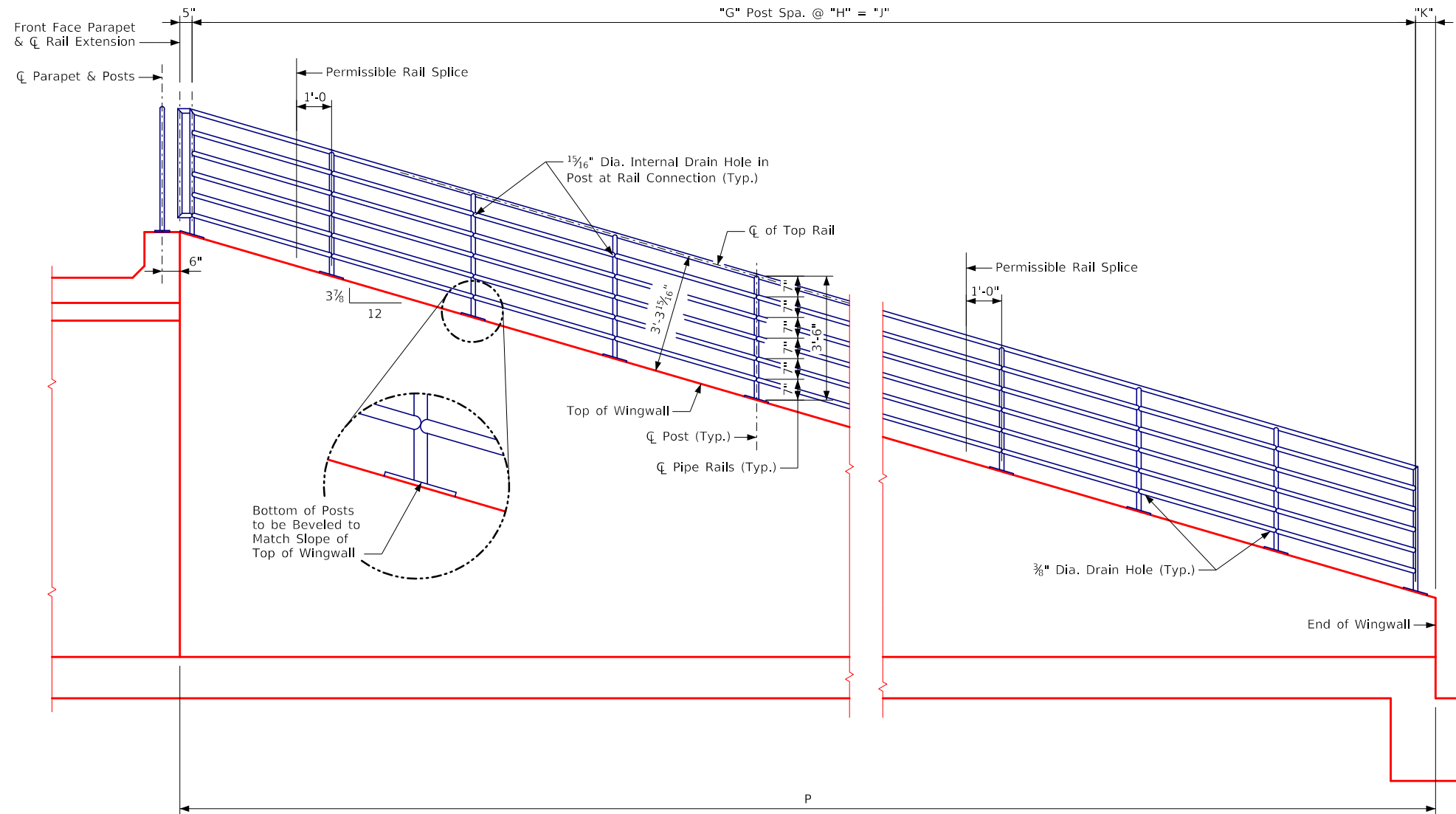

Elevation View of Wingwall

Safety Rail Dimension Table						
Headwall	"E"	"F"	"G"	"H"	"J"	"K"
12'-0" x 11'-4"	3'-1 1/2"	12'-6"	9	3'-9"	33'-9"	10 1/2"
12'-0" x 12'-4"	3'-2"	12'-8"	10	3'-8 1/4"	36'-10 1/2"	10 1/8"
14'-0" x 12'-4"	3'-8"	14'-8"	10	3'-8 1/4"	36'-10 1/2"	10 1/8"

Notes:

1. Total linear feet quantity of "Steel Pipe Pedestrian Handrail" provided on the "Estimated Quantities Table" in the design plans.
2. Post bases to be installed, centered on top of wingwalls and parapet and spaced as shown.
3. See Sheet PT-FWH 0-1-20 for Dimension P.
4. See Sheet PT-RCB 12-11-20, PT-RCB 12-12-20 or PT-RCB 14-12-20 For Dimensions C & S.

LATEST REVISION DATE	 APPROVED BY BRIDGE ENGINEER	 Cast-In-Place Standard Design - Walkways and Trails Reinforced Concrete Pedestrian Tunnel August, 2020	
		Safety Rail Details	PT-SR 1-20

ENGLISH_LRFD_SIGNED_PEDESTRIAN_TUNNEL_STANDARDS.DGN - PT-SR 2-20 - THIS SHEET ISSUED 08-2020

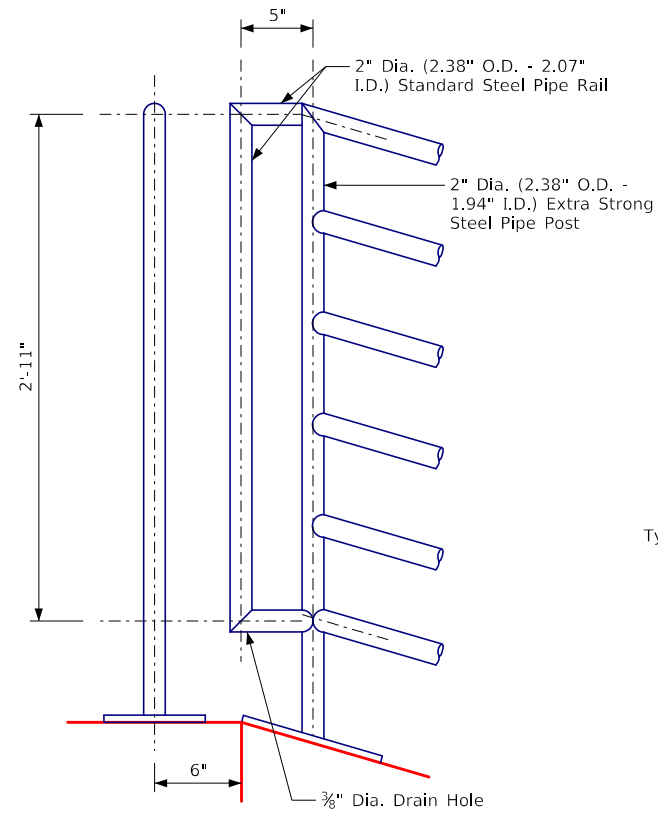

End Rail Details

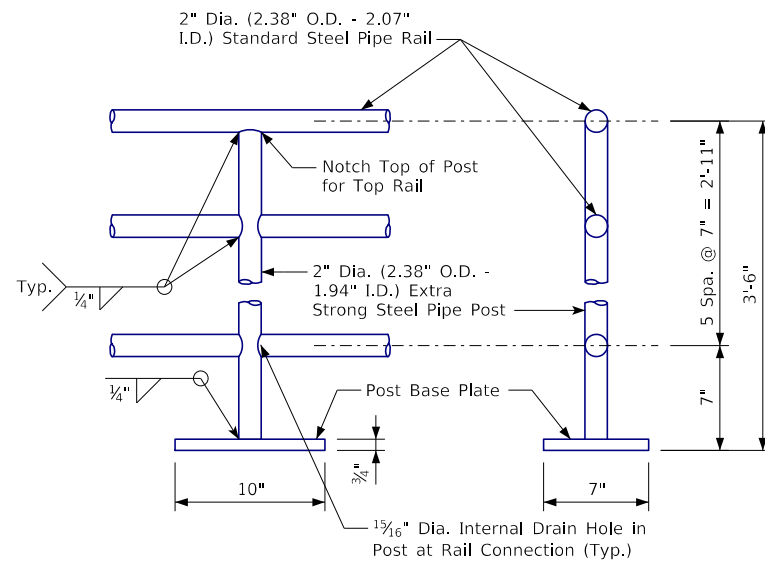

Pipe Handrail Details

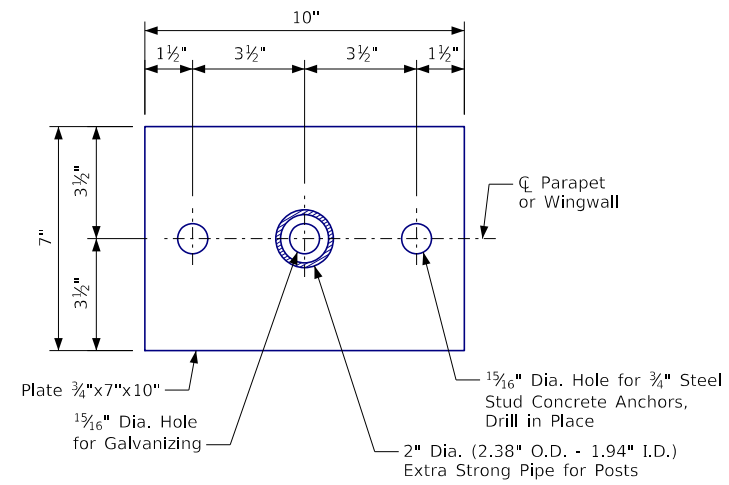

Post Base Plate and Shim Details

Note:
Pipe handrail assembly to be galvanized after fabrication. Drilled-in drain holes, to facilitate the hot dip galvanizing process, shall be indicated on the shop drawings.

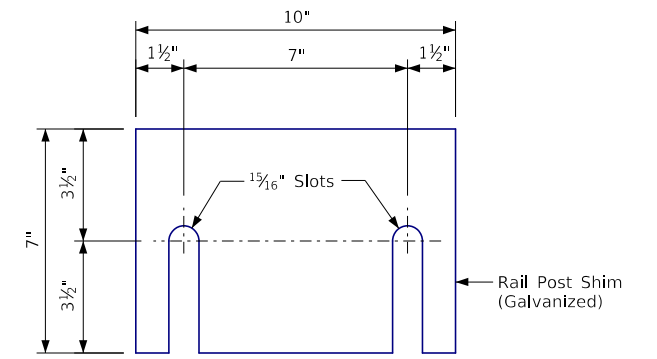

Note:
Provide 1/16" galvanized steel shim at each rail post. Use as required.

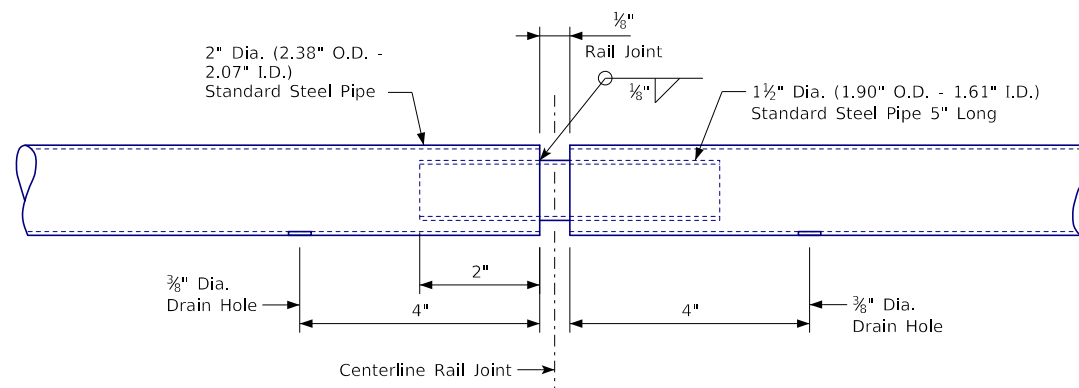

Rail Joint Detail

Pedestrian Hand Rail Notes:

1. The steel pipe pedestrian hand rail is to be bid on a linear foot basis measured end to end of rail. The price bid for "Steel Pipe Pedestrian Handrail" shall be full compensation for furnishing all material, including anchor bolts and shims, and all of the equipment and labor required to erect the rail in accordance with these Plans and Specifications.
2. The material for tube rails, posts and splice tubes shall be standard and extra strong steel pipe meeting the requirements of ASTM A53, Type E or S, Grade B. Base plates and shims shall meet the requirements of ASTM A36. Panels and end sections shall be galvanized, after fabrication, in accordance with the requirements of ASTM A123.
3. Ends of rail sections are to be sawed or milled. All cut ends are to be true, smooth, and free of burrs or ragged edges.
4. No painting will be required.
5. The stud concrete anchors shall be galvanized and have a minimum pull out strength of 8000 pounds based on 4000 PSI concrete.
6. Rail is to be centered along the centerline of wingwalls and parapets.
7. Posts shall be set plumb.

LATEST REVISION DATE	APPROVED BY BRIDGE ENGINEER <i>[Signature]</i>		
		Cast-In-Place Standard Design - Walkways and Trails Reinforced Concrete Pedestrian Tunnel August, 2020	
		Safety Rail Details	PT-SR 2-20

General Notes for Textured Concrete Form Liners:

1. See individual design sheets for specific notes and details describing the features which incorporate textured concrete. Work performed to create textured concrete shall be in accordance with the Standard Specifications for formwork and the following:
2. Form the textured concrete surface using a form liner system made of high-strength urethane elastomer, plastic or flexible foam materials capable of withstanding anticipated concrete pour pressures without leakage or causing physical defects. Form liners shall easily attach to forms and be removable without causing concrete surface damage. If recommended by the form liner Manufacturer, use structural backers to prevent deformation of the liner during loading of the forms. The liners shall be designed to form surfaces conforming to the design intent including the shape, lines and dimensions shown in the plans and to avoid visible pattern repeats. Match pattern features at form liner joints to minimize pattern repeats and make the formed concrete surface appear uniform and continuous without visible seams and form marks. When joints are unavoidable, make joints along main features of the pattern in accordance with Manufacturer's recommendations.
3. Form liner edges following curves are to be cut cleanly and parallel to the curve. Use adequate blocking, sealing and other means in order to maintain the appropriate depth and character of texture at cut edges of liners and to prevent mortar leakage.
4. During loading of forms with concrete, take extra care to adequately vibrate concrete in order to maintain all intended features of the form liner in the final surface and to prevent voids. Following removal of forms, finish minor defects to blend with the balance of the surface texture. The completed surface shall be free of blemishes, surface voids and conspicuous form marks to the satisfaction of the Engineer. The Contractor shall correct, at his own cost, any surface defects.
5. Verify that release agents used are compatible with form liner material, and are non-staining. Apply release agent in accordance with the form liner Manufacturer's recommendations.
6. If used, form ties shall be made of non-corrosive materials when the portion permanently embedded in the concrete is less ties and accessories in stone pattern mortar joints and at high points of finished wall.
7. If heating forms during cold weather construction, take special care to avoid damaging form liners. Overheating can warp or melt some form liner materials.
8. Strip formwork using techniques in accordance with liner manufacturer's recommendations after the concrete has achieved the strengths and cure times required by the plans and applicable Specifications. Clean and repair form liner surfaces prior to use. Do not use split, frayed, delaminated or otherwise damaged form liners.
9. All costs associated with concrete texturing and form liners are to be included in the bid item "Structural Concrete (RCB Culvert)".

General Notes for Concrete Rustication:

1. Strips and panels used as inserts within concrete forms to create the rustication features may be made of wood, steel, plastic or other nonporous material capable of withstanding anticipated concrete pour pressures without physical defects. Wood inserts, if used, shall be free of warp, twist, checks or cracks, and shall be presoaked prior to placement of concrete in the forms.
2. Rustication inserts shall easily attach to forms and shall not allow leakage of concrete between the form and the insert. When steel forms are used, rustication strips may be rigidly attached to the inside surfaces of the forms. When steel forms are not used, rustication strips and other inserts for small recesses on exposed concrete surfaces shall be fastened to the forms in a manner that will permit them to remain in place when the forms are removed. Leave inserts in place until they can be removed without damage to the surrounding concrete.
3. The inserts shall be designed to form surfaces and features conforming to the design intent including the shape, lines, depths and dimensions shown in the plans. Create inserts using a minimum number of splice joints in their length. Splices, if used, shall be tightly joined so as not to allow gaps or leaks, and shall not create any change in alignment or shape of the rustication feature. Do not locate form ties within concrete rustications.
4. For rustication features following the perimeter of rounded surfaces, it may be necessary to use multiple layers of insert material in order to achieve the radius curve. This is acceptable, provided that the final shape, line, depth, and dimension of the features are maintained in the final result.
5. During loading of forms with concrete, take extra care to ensure proper consolidation of concrete around all rustication inserts to preserve the shape, line and depth of all intended features in the final concrete surface. Following removal of forms, repair all defects to achieve the rustication features as specified in the plans. Patch voids, honeycomb areas, etc., in accordance with the Standard Specifications. If surfaces will not receive a colored sealer coating, add white cement to the patching mortar to lighten it in order to match surrounding concrete when dry. Completed surface shall be free from blemishes, surface voids and conspicuous form marks to the satisfaction of the Engineer. The Contractor shall correct, at his own cost, any surface defects.
6. All costs associated with concrete rustication are to be included in the bid item "Structural Concrete (RCB Culvert)".

Anti-Graffiti Coating Notes:

1. Anti-graffiti surface preparation and application shall be in accordance with the "Special Provisions for Anti-Graffiti Coating" and material used shall be an approved type in accordance with Materials I.M. 491.23. Color shall be clear. Anti-graffiti coating must be compatible with other concrete coatings used on the project in accordance with the Manufacturer's recommendations.
2. Anti-graffiti coating shall be applied to all interior surfaces of the pedestrian tunnel except the walking surface, and all exposed vertical surfaces of the headwalls including the parapets. Anti-graffiti coating is not required on the top horizontal surfaces of the parapets. All costs for anti-graffiti coating shall be included in the bid item "Anti-Graffiti Coating" and is paid for on a square yard basis.

Tunnel Concrete Coating Notes:

1. All interior surfaces of the pedestrian tunnel except the walking surface, to the limits of the front face of parapets, shall be finished with a 100% acrylic, vapor permeable masonry coating. The coating used shall be certified to allow water vapor transmission in accordance with ASTM E96 or ASTM D1653.
2. The 100% acrylic, vapor permeable masonry coating shall be one of the following listed products:
 - A. TK Products Tri-sheen Acrylic
 - B. Sherwin Williams A-100
 - C. Chemrex Inc. Thorosheen
 - D. Edison Coatings Aqryl-X 200
 - E. Approved equal; submit product information to the Iowa DOT, Bridges and Structures Bureau, Ames, IA 50010. Do not order materials prior to receiving approval for use on the project.
3. Prior to concrete coating application, prepare surfaces in accordance with the "Developmental Specifications for Concrete Surface Preparation and Testing Prior to Coating Application". Apply 100% acrylic, vapor permeable masonry coating in accordance with the "Developmental Specifications for Structural Concrete Coating".
4. One color of concrete coating is to be used on the pedestrian tunnel. The color shall be white matching SAE AMS-STD-595 color number 27925 (semi-gloss). Submit product specifications and color samples in accordance with the "Developmental Specifications for Structural Concrete Coating".
5. No coating overspray or other contamination shall be allowed on the floor surface of the pedestrian tunnel, on the adjacent parapets, headwalls, or on the approach pavement. Take special care to avoid contamination of adjacent surfaces.
6. All costs associated with surface preparation and application of 100% acrylic, vapor permeable masonry coating are to be included in the bid item "Structural Concrete Coating".

LATEST REVISION DATE	APPROVED BY BRIDGE ENGINEER		
		Cast-In-Place Standard Design - Walkways and Trails Reinforced Concrete Pedestrian Tunnel August, 2020	
		Aesthetic Treatment General Notes	PT-AD 1-20

ENGLISH_LRFD_SIGNED_PEDESTRIAN_TUNNEL_STANDARDS.DGN - PT-AD 2-20 - THIS SHEET ISSUED 08-2020

Textured Concrete Notes:

1. This work consists of applying textured finishes on all designated concrete surfaces of the pedestrian tunnel headwalls shown in this plan. See "General Notes for Textured Concrete Form Liners" on sheet PT-AD 1-20 for more information regarding the use of form liners. The textured concrete mockup panel must be reviewed and approved by the Engineer before beginning production concrete work that includes texture.
2. The form liner used to produce the texture shown in the plan details shall produce a textured effect of a realistic, random drystack stone masonry surface having stones of varying size and shape. Individual stone dimensions shall be between 3 and 42 inches. Maximum depth of texture shall be between 1½ and 2½ inches.
3. Obtain texture form liner materials from one of the following manufacturers:
 - A. Custom Rock International (Pattern Nos. 1203, 1208)
 - B. Fitzgerald Formliners (Pattern No. 17911)
 - C. Architectural Polymers (Pattern No. 911)
 - D. Other Manufacturers and patterns submitted to and approved by the Iowa Department of Transportation, Bridges and Structures Bureau.
4. The pedestrian tunnel headwall surfaces as designated in the plans shall also receive concrete rustication. See "General Notes for Concrete Rustication" on Sheet PT-AD 1-20 for more information regarding approved techniques and methods of concrete rustication.

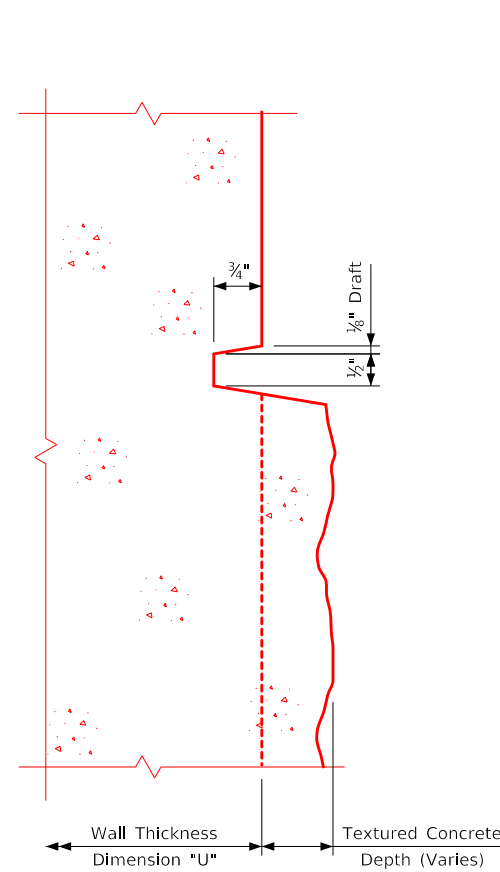

Section A-A

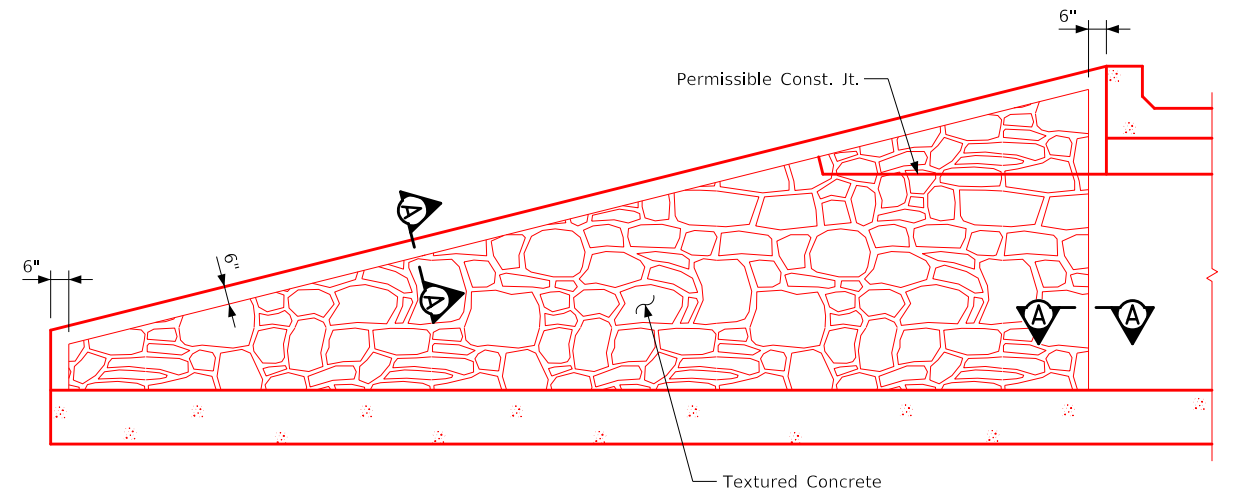

Typical Wingwall Elevation

Texture Mockup Panel Notes:

1. Prior to beginning any production concrete work that includes texture, a textured concrete mockup panel must be reviewed and approved by the Engineer.
2. Construct a 3-foot high, by 6-inch wide (Min.), by 3-foot long mockup panel in accordance with the Standard Specifications and these plans. See mockup details on this design sheet.
3. Cast the mockup panel(s) on site, using the same forming methods, procedures, form liners, and concrete mixture(s) as are proposed for the production work. Textured face shall be vertical during the casting process. A single mat of No. 5 reinforcing bars in two directions shall be centered within the panel. If the mockup panel is rejected, construct a new mockup panel as directed by the Engineer. Begin textured concrete production work only after the mockup has been approved by the Engineer.
4. All costs associated with the textured concrete mockup panel(s) shall be included in the price bid for "Structural Concrete (RCB Culvert)".

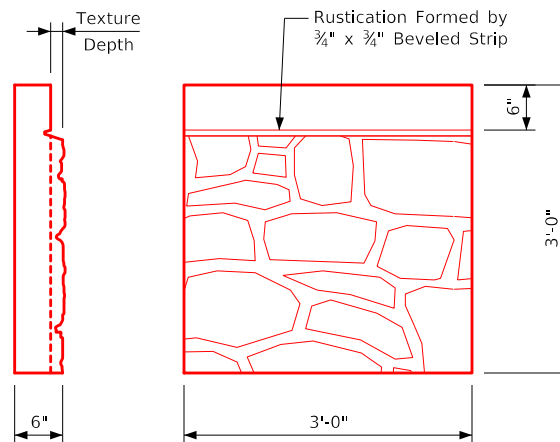

Texture Mockup Panel Details

Textured Concrete - One Headwall	
Location	Quantity (CY)
12' x 11'-4" Headwall	1.9
12' x 12'-4" Headwall	2.2
14' x 12'-4" Headwall	2.2

Note:
Quantity is based on an average relief of 1¼" over the surface area of the wingwall.

LATEST REVISION DATE	APPROVED BY BRIDGE ENGINEER		
		Cast-In-Place Standard Design - Walkways and Trails Reinforced Concrete Pedestrian Tunnel August, 2020	
		Pedestrian Tunnel Textured Concrete	PT-AD 2-20