



# Precast Reinforced Concrete Pedestrian Tunnel Standards

## General Notes:

- The reinforced concrete pedestrian tunnel sections are designed for HL-93 live load and earth fills of varying heights.
- Vertical earth pressure,  $EV=0.120$  kcf.  
Horizontal earth pressure,  $EH_{max} = 0.060$  kcf max,  $EH_{min} = 0.030$  kcf.
- All dimensions are in feet and inches unless otherwise noted or shown.
- These pedestrian tunnel standards label all reinforcing steel with English notation (#3 is  $\frac{3}{8}$  inch diameter bar). English reinforcing steel received may display the following "bar designation". The "bar designation" is the stamped impression on the reinforcing bars, and is equivalent to the bar diameter in millimeters.

English Size	4	5	6	7	8	9
Bar Designation	13	16	19	22	25	29

## Precast Barrel Notes:

- The precast concrete pedestrian tunnel sections are designed for Class 2 exposure conditions.
- The clear distance from face of concrete to near edge or end of reinforcing bar to be  $1\frac{1}{2}$ " min. and 2" max., unless otherwise noted or shown.
- The reinforcement supplied for the precast concrete pedestrian tunnel sections shall be plain and/or deformed welded wire reinforcement (WWR)  $F_y = 65$  ksi, and/or Grade 60 reinforcing steel in accordance with the Standard Specifications. The reinforcement areas are based on welded wire reinforcement. If reinforcing bars are substituted for welded wire reinforcement, the reinforcement areas shall be increased by 8%. The barrel sections in these standards were designed with plain WWR,  $F_y = 65$  ksi.
- Any of the following combinations of reinforcement may be used:
  - 1 or 2 layers of welded wire reinforcement or
  - 1 layer of welded wire reinforcement and 1 layer of reinforcement bars or
  - 1 layer of reinforcement bars.
 The reinforcement shall be developed in accordance with AASHTO LRFD Specifications.
- The maximum size of reinforcement bars shall be #6.
- The maximum welded wire reinforcement size shall be a W23/D23 per layer (maximum of 2 layers).
- The spacing center to center of the transverse wires or bars shall not be less than 2" nor more than 4". The spacing center to center of the longitudinal wires or bars shall not be more than 8".
- Welding will not be allowed on reinforcement bars or welded wire reinforcement, except that the original welding required to manufacture the wire reinforcement is acceptable.
- When reinforcement is cut, additional reinforcement shall be added on both sides of the cut member to replace or exceed the cut reinforcement.
- ET Culvert Software version 4.3.1.0 was used for the design of the barrel sections for these standards.
- The ends of precast barrel sections adjacent to the cast-in-place end section shall omit the tongue and groove to facilitate placement of the 5z1 dowel bars.
- The surface of the precast barrel floor shall be intentionally roughened to a minimum depth of  $\frac{1}{8}$ " and a maximum depth of  $\frac{1}{4}$ ". This roughened surface shall be accomplished on plastic concrete by use of a mechanical device as prescribed in Article 2301.03,H of the Standard Specifications or on hardened concrete by uniformly mechanically scarifying the entire floor area. Sandblasting is not permitted. The intent is to give the contractor the option of achieving the required surface roughness on the plastic or hardened concrete so the overlay will bond properly.
- Recessed galvanized lifting pin anchors shall be furnished with the precast barrel sections and located as determined by the Contractor. Prior to backfilling, the recessed areas surrounding the lifting pins shall be grouted flush with the top surface of the precast barrel section. Grout shall consist of 1 part cement and 2 parts sand. Use air entrained portland cement. Grout mix shall have a maximum slump of 4 inches.

## Cast-In-Place Barrel and Headwall Notes:

- The cast-in-place concrete pedestrian tunnel sections are designed for Class 1 exposure conditions.
- All slab and floor reinforcing steel is to be supported at intervals of not more than 3'-0" in either direction as outlined in the Standard Specifications.
- Floor of barrel, headwall apron and concrete overlay shall receive a broomed finish meeting the requirements of Article 2511.03,B,3,b, of the Standard Specifications and meet the smoothness requirements of Article 2511.03,B,5,b, of the Standard Specifications. Sides of footing are to be formed to insure correct line and grade.
- The permissible construction joint at the top of the walls may be lowered at the Contractor's option with Engineer's approval.
- The reinforcement supplied for the cast-in-place barrel end sections and headwalls shall be Grade 60 reinforcement in accordance with the Standard Specifications. The design stresses are based on Grade 60 reinforcement.
- The vertical bars in the walls may be spliced above the footing at the Contractor's option as follows:

Bar Size Number	4	5	6	7
Minimum Splice Length	20"	24"	29"	34"

This splice, if used, will be at the Contractor's expense.

- Reinforcing bar clearances will be as follows:
  - Edge clearances: 2" except
    - Top of floor:  $2\frac{1}{4}$ " to near transverse reinforcing bar
    - Bottom of floor:  $3\frac{1}{2}$ " to near transverse reinforcing bar
  - End clearances:
    - Vertical top: 2"
    - Vertical bottom: 3" or  $3\frac{1}{2}$ " if overall height of the culvert is not to a full inch
    - Transverse: 2"
- All reinforcing bars and bars noted as dowels supplied for this structure shall be deformed reinforcement unless otherwise noted or shown.
- All construction joints shall be formed with a beveled keyway.
- All beveled keyways shall be centered.
- Keyway size shall be 2"x4" except the keyway between the barrel floor and wall and the headwall apron and wingwall shall be 2"x6".
- Keyway dimensions shown on the plans are based on nominal dimensions unless stated otherwise. In addition, the bevel used on the keyway shall be limited to a maximum of 10 degrees from vertical.
- Bentonite waterstop shall be applied to the longitudinal construction joints at the top and bottom of the walls, to transverse construction joint in the slab, walls, and floor at interface with precast barrel section, and to permissible vertical joint at front face of parapet if used. Bentonite waterstop shall be installed with a manufacturer's approved adhesive in accordance with the manufacturer's recommendations. The following is a listing of approved bentonite waterstop:
  - Greenstreak Swellstop
  - Henry Hydro-Flex
  - Approved equal
- Bentonite waterstop shall be protected from exposure to moisture prior to concrete placement. Bentonite waterstop that was swelled prior to concrete placement shall be replaced at no cost to the State.

## Index for Precast Pedestrian Tunnel Standards:

PPT G1-20	Index & General Notes
PPT G2-20	Installation Notes
PPT G3-20	Typical Tunnel Details
PPT-RCB 12-20	Tunnel Details 12'-0 Span
PPT-RCB 14-20	Tunnel Details 14'-0 Span
PPT-FWH 0-1-20	Flared Wing Headwall Dimension Plan & Table
PPT-FWH 0-2-20	Flared Wing Headwall Apron Layout & Curtain Wall Details
PPT-FWH 0-3-20	Flared Wing Headwall Wing Layouts & Cross Section Details
PPT-FWH 0-4-20	Flared Wing Headwall Quantity Tabulation
PPT-FWH 0-5-20	Barrel End Section Quantity Tabulation & Details
PPT-SR 1-20	Safety Rail Details
PPT-SR 2-20	Safety Rail Details
PPT-AD 1-20	Aesthetic Treatment General Notes
PPT-AD 2-20	Pedestrian Tunnel Textured Concrete

## Specifications:

Design:



AASHTO LRFD Bridge Design Specifications, 8th Ed., Series of 2017.

Construction:

Iowa Department of Transportation Standard Specifications for Highway and Bridge Construction, current series, plus applicable General Supplemental Specifications, Developmental Specifications, Supplemental Specifications and Special Provisions.

## Design Stresses:

Design stresses for the following materials are in accordance with the AASHTO LRFD Bridge Design Specifications, 8th Ed., Series of 2017: Bar reinforcement in accordance with AASHTO LRFD Section 5, Grade 60. Welded wire reinforcement in accordance with AASHTO LRFD Section 5, Grade 65 Min. Concrete in accordance with AASHTO LRFD Section 5;  $f'_c$  for precast barrel sections as noted on Sheets PPT-RCB 12-20 and PPT-RCB 14-20,  $f'_c = 4$  ksi for cast-in-place barrel end sections and headwalls.

LATEST REVISION DATE	 APPROVED BY BRIDGE ENGINEER	 Precast Standard Design - Walkways and Trails <b>Precast Reinforced Concrete Pedestrian Tunnel</b> August, 2020	
		Index & General Notes	PPT G1-20

REVISED 01-2023: Added notes 4, 5 and 6. Notes 7, 8 and 9 were notes 4, 5, and 6 respectively.  
 ENGLISH\_LRFD\_SIGNED\_PRECAST\_PEDESTRIAN\_TUNNEL\_STANDARDS.DGN - PPT G2-20 - THIS SHEET ISSUED 08-2020

**Installation Notes:**

1. Precast concrete box culvert sections shall be laid with the groove end of each section up-grade, and the sections shall be tightly joined. Concrete ties to be used only to hold box sections together, not for pulling sections tight. Joint openings between sections should be as tight as practicable and limited to a maximum of 1/2 inch openings. A pipe puller or ratchet style load binder shall be used to achieve the required joint opening.
2. The joints shall be sealed with a flexible water tight 1 inch butyl rope gasket as per Materials I.M. 491.09. Butyl rope gasket shall be installed in accordance with the recommendations of the manufacturer and as shown in the "Typical Joint Detail" on sheet PPT G3-20. Butyl rope gasket shall extend around the walls, floor and slab of the precast barrel joints. All joints shall be trimmed clean on the inside after sealing.
3. Homing pressure shall be applied to barrels during installation to compress the butyl rope gasket. Homing pressure shall be held for a sufficient period of time to allow for maximum compression of the joint. Method of applying the homing pressure shall not damage the barrel and shall be approved by the Engineer. Ties shall not be used to apply homing pressure. Ties shall be snug tight prior to release of the homing pressure.
4. Burr threads of Concrete Box Ties without damaging galvanizing to prevent nut rotation after tightening is complete.
5. The Granular Leveling Material shall be installed in accordance with Article 2402.03, H, 4, of the Standard Specifications. If larger granular material is installed below the granular leveling material, the Contractor shall place engineering fabric below the granular leveling material to separate the layers. The fabric shall be oversized by a minimum of 1 foot on all edges to contain the Granular Leveling Material.
6. All costs including material and labor associated with providing and installing the engineering fabric described above shall be included in the bid item "Precast Reinforced Concrete Pedestrian Tunnel". The engineering fabric shall be in accordance with Article 4196.01, B, 3, of the Standard Specifications.
7. During backfilling the compaction adjacent to the bottom corner radii or chamfer shall be accomplished with a mechanical hand compactor.
8. Waterproof membrane shall be applied to the outside face of the transverse construction joints in the slab and walls. Waterproof membrane shall be 1'-6" wide and be centered on the joint. Waterproof membrane shall be installed with a manufacturer's approved adhesive in accordance with the manufacturer's recommendations. The following is a listing of approved waterproof membrane:
  - a. W.R. Meadows Mel-Rol
  - b. Grace Construction Products Bituthene 3000
  - c. Approved equal
9. Precast barrels shall be tied to the cast-in-place barrel end sections with 5z1 dowels and bentonite waterstop in precast keyway. Dowels shall be set around the entire periphery of the barrel at 1'-0" maximum center to center spacing. Dowels shall be centered in the precast barrel slab, wall and floor. Dowels shall be set in drilled holes. Holes shall be 10" deep. Dowels shall be set with a polymer grout system in accordance with Article 2301.03,E, of the Standard Specifications. Set dowels in accordance with grout manufacturer's recommendations.

01-2023 LATEST REVISION DATE	 APPROVED BY BRIDGE ENGINEER	 Precast Standard Design - Walkways and Trails <b>Precast Reinforced Concrete Pedestrian Tunnel</b> August, 2020	
		Installation Notes	PPT G2-20

REVISED 01-2023: Added note to burr threads of Concrete Box Ties. ENGLISH\_LRFD\_SIGNED\_PRECAST\_PEDESTRIAN\_TUNNEL\_STANDARDS.DGN - PPT G3-20 - THIS SHEET ISSUED 08-2020

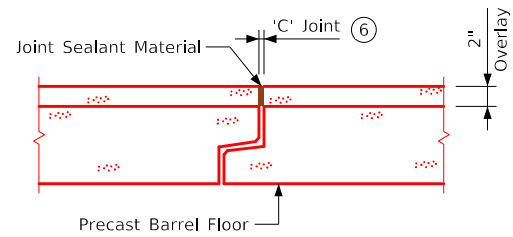

Section A-A

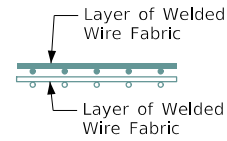

Fabric Layer Detail

Note:  
When more than one layer of welded wire fabric is used to obtain the required reinforcement areas, the wires of the welded wire fabric shall be placed as shown.

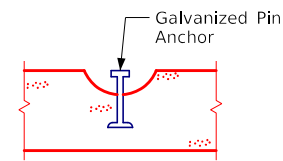

Lifting Pin Detail

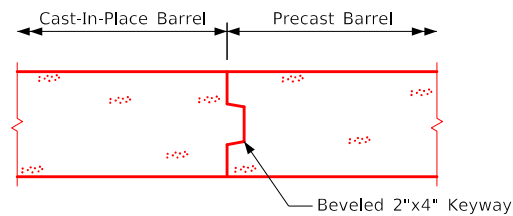

Joint Detail at Cast-In-Place Barrel Connection

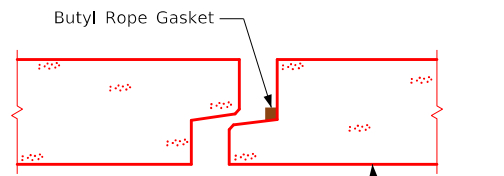

Typical Joint Detail

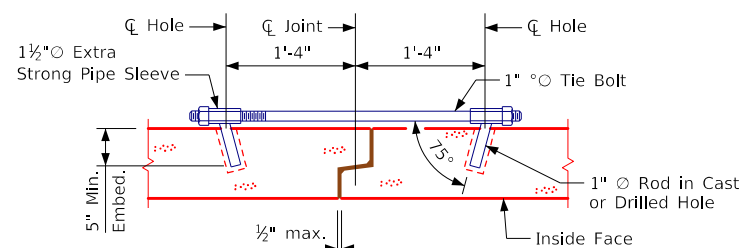

Galvanized Tie Bolt Detail  
(Concealed Hole Design)

Note:  
Burr threads of Concrete Box Ties without damaging galvanizing to prevent nut rotation after tightening is complete.

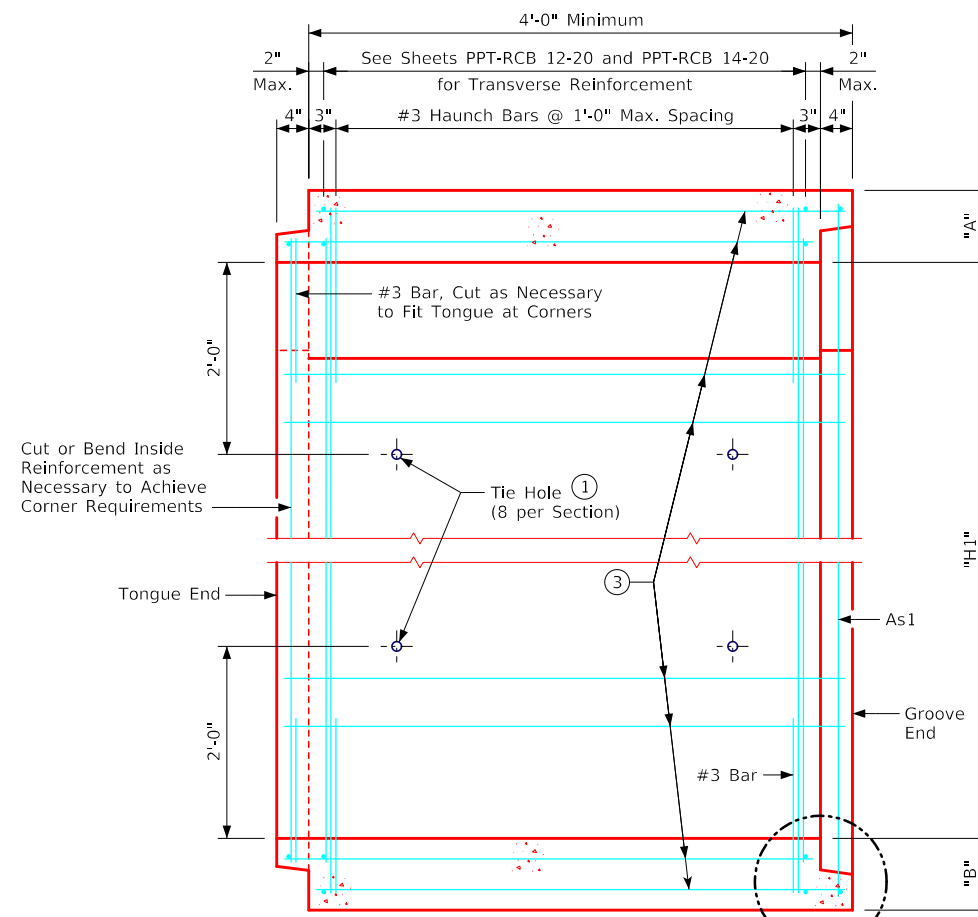

Longitudinal Barrel Section  
(Reinforcement Bar Option Shown)

Haunch Bars to Extend a Minimum of 2" Beyond Inside Reinforcing, but not Past Outside Reinforcing (Typ.)

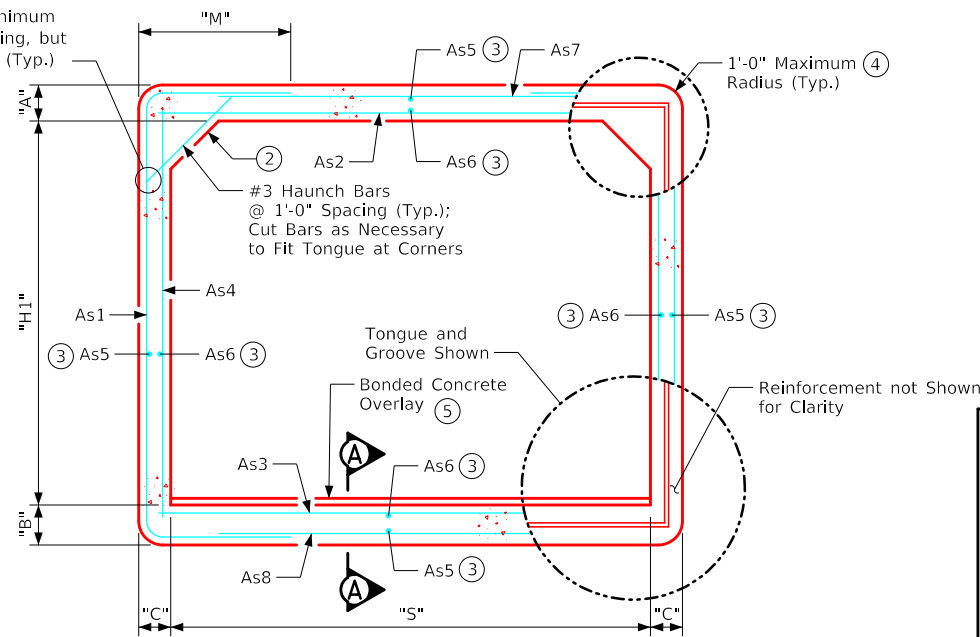

Transverse Barrel Section  
(Reinforcement Bar Option Shown)

Notes:

- ① Culvert ties are to be 1"Ø rods. See "Tie Bolt Connection Detail" this sheet.
- ② Top corner haunch size shall be 12" vertical, 12" horizontal on all box sizes.
- ③ Longitudinal reinforcement denoted as As5 & As6 must be placed in slab, floor, and walls and must be 0.06 in<sup>2</sup>/ft min.
- ④ Optional squared corners with 3/4" to 2" chamfer.
- ⑤ Material and construction of bonded PCC overlay shall meet the requirements of Article 2310 of the Standard Specifications. Seal coat bond breaker shall not be used.
- ⑥ 'C' joints shall be located at all precast barrel floor joints. Saw cuts for 'C' joints shall be full depth of the concrete overlay and extend as close as practical to the precast barrel wall without damaging the wall. See Standard Road Plan PV-101 for 'C' joint details.

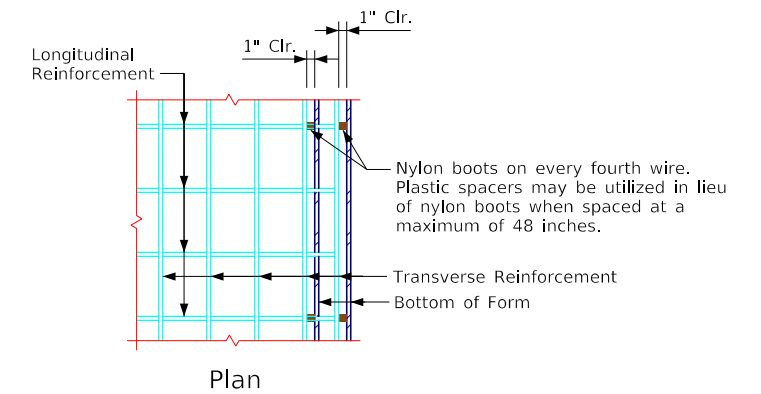

Plan

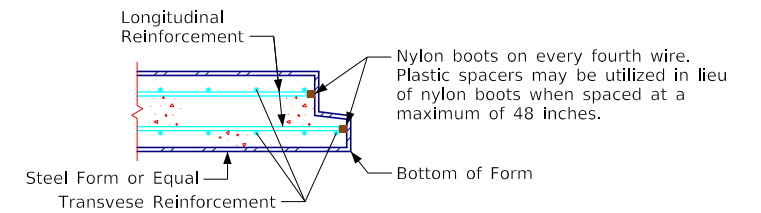

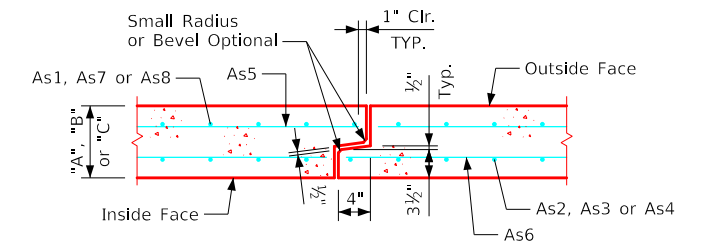

Section

Forming Detail

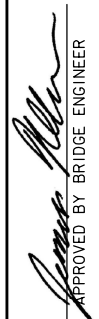

Tongue and Groove Joint Detail

01-2023 LATEST REVISION DATE   APPROVED BY BRIDGE ENGINEER	 Precast Standard Design - Walkways and Trails <b>Precast Reinforced Concrete Pedestrian Tunnel</b> August, 2020	
	Typical Tunnel Details	PPT G3-20

ENGLISH\_LRFD\_SIGNED\_PRECAST\_PEDESTRIAN\_TUNNEL\_STANDARDS.DGN - PPT-RCB 12-20 - THIS SHEET ISSUED 08-2020

Variable Dimensions and Quantities for 12' Span Barrel Sections																					
Dimensions									Reinforcement Requirements											Weight (LB/FT)	
									As1			As2		As3		As4		As7/As8			
Size	Class	f'c (ksi)	Fill (FT)	S (FT)	H1 (FT)	A (IN)	B (IN)	C (IN)	Area (IN <sup>2</sup> /FT)	Length	M	Area (IN <sup>2</sup> /FT)	Length	Area (IN <sup>2</sup> /FT)	Length	Area (IN <sup>2</sup> /FT)	Length	Area (IN <sup>2</sup> /FT)	Length	Area (IN <sup>2</sup> /FT)	Length
12x11	1	5.0	2-6	12	11	10	10	9	0.74	18'-6"	3'-3"	1.08	12'-6"	1.17	12'-6"	0.24	11'-6"	0.24	11'-6"	6000	
	2	5.0	7-12	12	11	10	10	9	1.02	18'-10"	3'-5"	1.46	12'-6"	1.55	12'-6"	0.24	11'-6"	0.24	11'-6"	6000	
	3	5.0	13-15	12	11	12	12	10	0.93	18'-2"	2'-11"	1.23	12'-6"	1.29	12'-6"	0.29	11'-6"	0.29	11'-8"	7000	
12x12	1	5.0	2-5	12	12	10	10	9	0.80	21'-10"	4'-5"	1.16	12'-6"	1.25	12'-6"	0.29	12'-6"	0.24	11'-6"	6225	
	2	5.0	6-9	12	12	10	10	9	0.98	21'-2"	4'-1"	1.32	12'-6"	1.47	12'-6"	0.32	12'-6"	0.24	11'-6"	6225	
	3	5.0	10-15	12	12	12	12	11	0.89	20'-0"	3'-4"	1.20	12'-6"	1.31	12'-6"	0.29	12'-6"	0.29	11'-10"	7600	

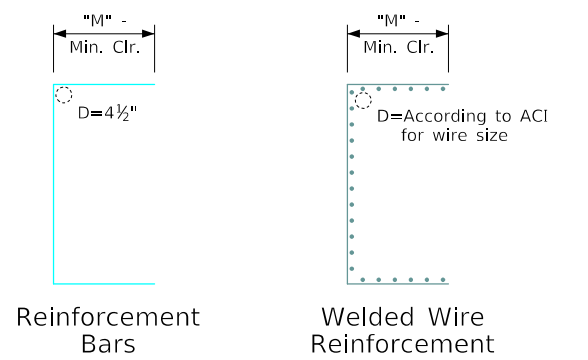

**Bent Bar Details**

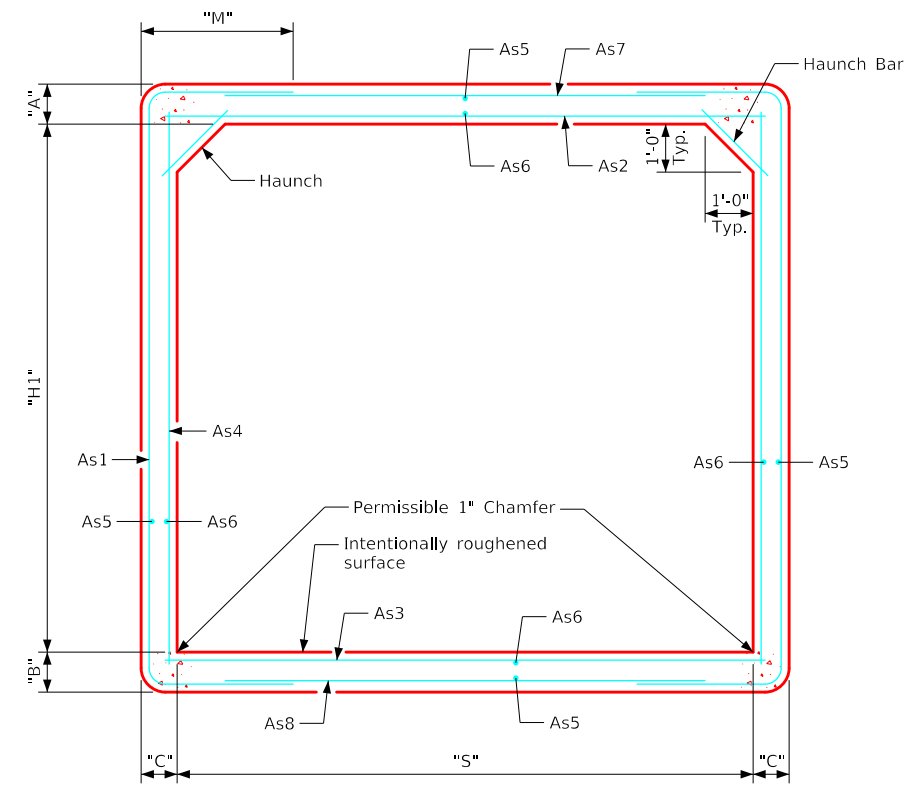

All dimensions are out to out.  
 D = pin diameter (min.).  
 Pin diameter may be increased if needed to maintain clear cover.



Typical Barrel Section

**Notes:**

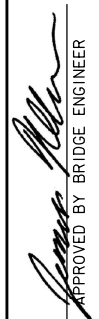
1. Longitudinal reinforcement denoted as As5 and As6 must be placed in slab, floor, and walls and must be 0.06 in<sup>2</sup>/ft minimum.
2. All reinforcement lengths and areas are minimum requirements.
3. If reinforcing bars are substituted for welded wire reinforcing, dimension "M" and/or length of the As7/As8 reinforcement shall be adjusted to ensure adequate lap length is provided.
4. Weight of sections assumes a density of 150 pcf and squared corners.
5. See Sheets PPT-RCB G1-20 and PPT-RCB G3-20 for additional information and notes.

LATEST REVISION DATE	 APPROVED BY BRIDGE ENGINEER	 Precast Standard Design - Walkways and Trails <b>Precast Reinforced Concrete Pedestrian Tunnel</b> August, 2020	
		Precast Tunnel Details 12' Span Barrel Sections	PPT-RCB 12-20

ENGLISH\_LRFD\_SIGNED\_PRECAST\_PEDESTRIAN\_TUNNEL\_STANDARDS.DGN - PPT-RCB 14-20 - THIS SHEET ISSUED 08-2020

Variable Dimensions and Quantities for 14' Span Barrel Sections																					
Dimensions									Reinforcement Requirements										Weight (LB/FT)		
									As1			As2		As3		As4		As7/As8			
Size	Class	f'c (ksi)	Fill (FT)	S (FT)	H1 (FT)	A (IN)	B (IN)	C (IN)	Area (IN <sup>2</sup> /FT)	Length	M	Area (IN <sup>2</sup> /FT)	Length	Area (IN <sup>2</sup> /FT)	Length	Area (IN <sup>2</sup> /FT)	Length	Area (IN <sup>2</sup> /FT)	Length	Area (IN <sup>2</sup> /FT)	Length
14x12	1	5.0	2-5	14	12	10	10	10	0.80	20'-10"	3'-11"	1.20	14'-6"	1.29	14'-6"	0.24	12'-6"	0.24	13'-8"	7070	
	2	5.0	6-9	14	12	10	10	10	1.01	20'-8"	3'-10"	1.47	14'-6"	1.62	14'-6"	0.24	12'-6"	0.24	13'-8"	7070	
	3	6.0	10-15	14	12	12	12	11	1.13	20'-2"	3'-5"	1.55	14'-6"	1.65	14'-6"	0.29	12'-6"	0.29	13'-10"	8200	

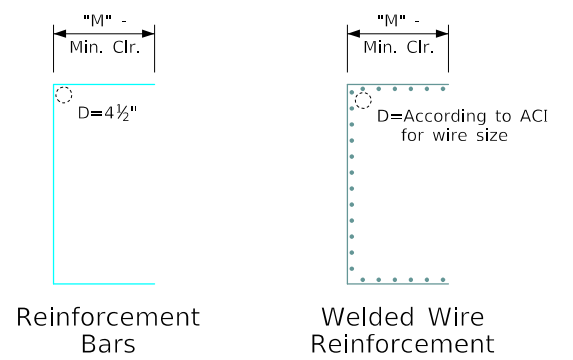

**Bent Bar Details**

All dimensions are out to out.  
 D = pin diameter (min.).  
 Pin diameter may be increased if needed to maintain clear cover.

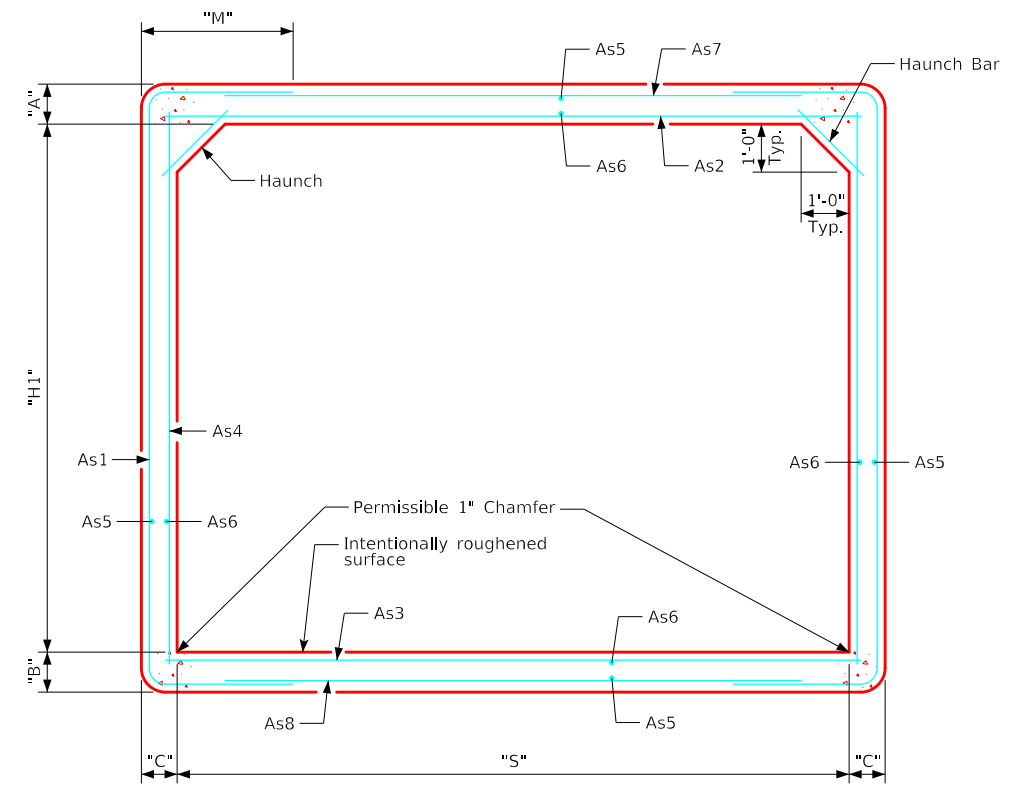

Typical Barrel Section

**Notes:**

1. Longitudinal reinforcement denoted as As5 and As6 must be placed in slab, floor, and walls and must be 0.06 in<sup>2</sup>/ft minimum.
2. All reinforcement lengths and areas are minimum requirements.
3. If reinforcing bars are substituted for welded wire reinforcing, dimension "M" and/or length of the As7/As8 reinforcement shall be adjusted to ensure adequate lap length is provided.
4. Weight of sections assumes a density of 150 pcf and squared corners.
5. See Sheets PPT-RCB G1-20 and PPT-RCB G3-20 for additional information and notes.

LATEST REVISION DATE	 APPROVED BY BRIDGE ENGINEER	 Precast Standard Design - Walkways and Trails <b>Precast Reinforced Concrete Pedestrian Tunnel</b> August, 2020	
		Precast Tunnel Details 14' Span Barrel Sections	PPT-RCB 14-20

ENGLISH\_LRFD\_SIGNED\_PRECAST\_PEDESTRIAN\_TUNNEL\_STANDARDS.DGN - PPT-FWH 0-1-20 - THIS SHEET ISSUED 08-2020

Dimension Table			
S x H2	14' x 11'-10"	12' x 11'-10"	12' x 10'-10"
A	35'-6"	35'-6"	32'-6"
D	8'-10½"	8'-10½"	8'-1½"
E	31'-9"	29'-9"	28'-3"
G1	31'-9"	29'-9"	28'-3"
G2	33'-8¾"	31'-8¾"	30'-0¾"
G3	11¾"	11¾"	1'-0"
P	36'-7½"	36'-7½"	33'-6"
R	38'-5½"	38'-5½"	35'-2½"
T	1'-2"	1'-2"	1'-2"
U	1'-0"	1'-0"	11"

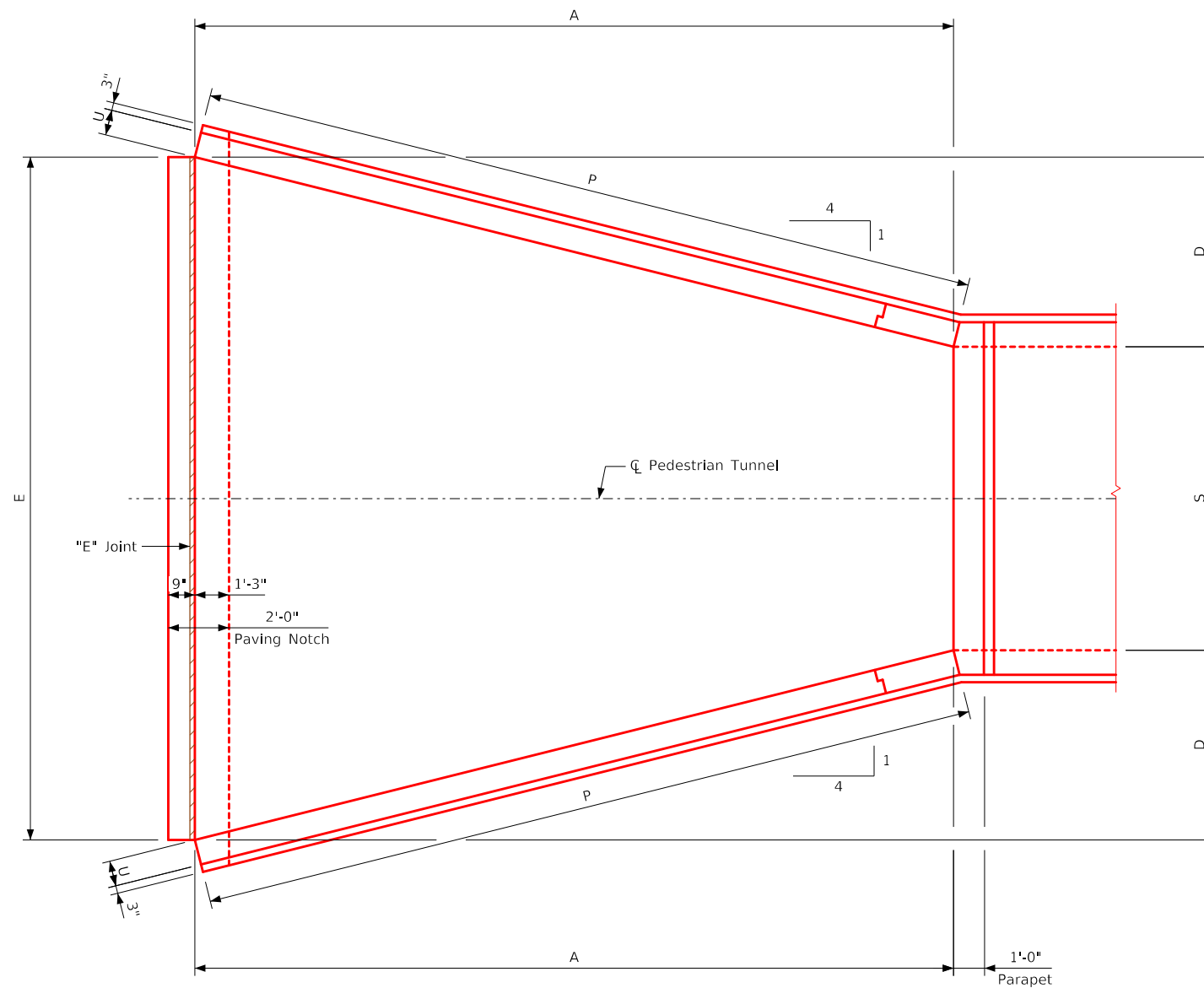

Plan View

Notes:

1. See Sheet PPT G1-20 for General Information, Specifications, and Design Stresses.
2. See Sheets PPT-FWH 0-2-20 & PPT-FWH 0-3-20 for location of certain dimensions tabulated.

LATEST REVISION DATE	 APPROVED BY BRIDGE ENGINEER	 Precast Standard Design - Walkways and Trails <b>Precast Reinforced Concrete Pedestrian Tunnel</b> August, 2020	
		Flared Wing Headwalls 0° Skew	PPT-FWH 0-1-20



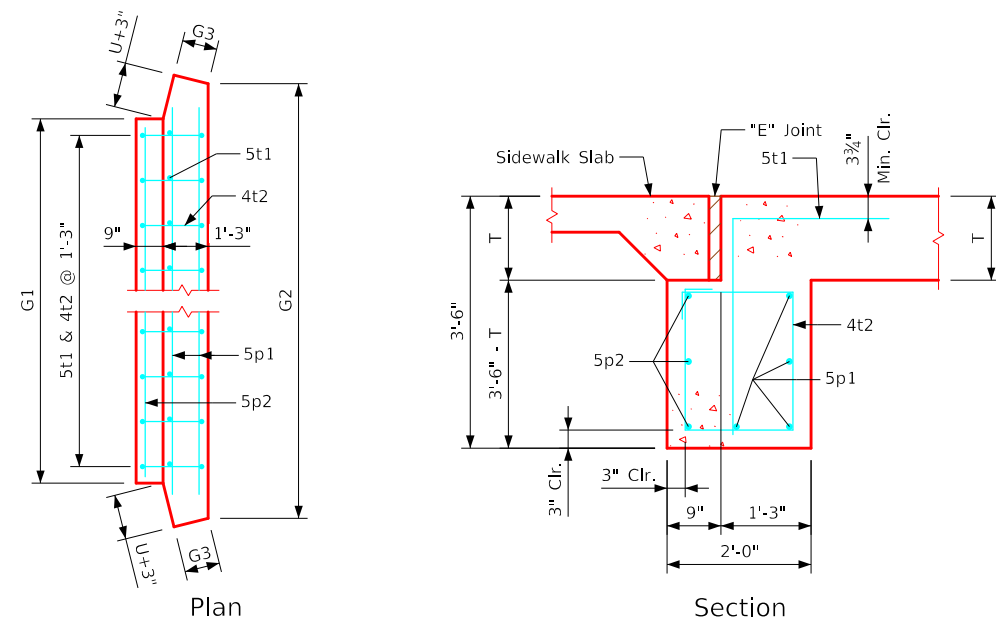

Paving Notch Details

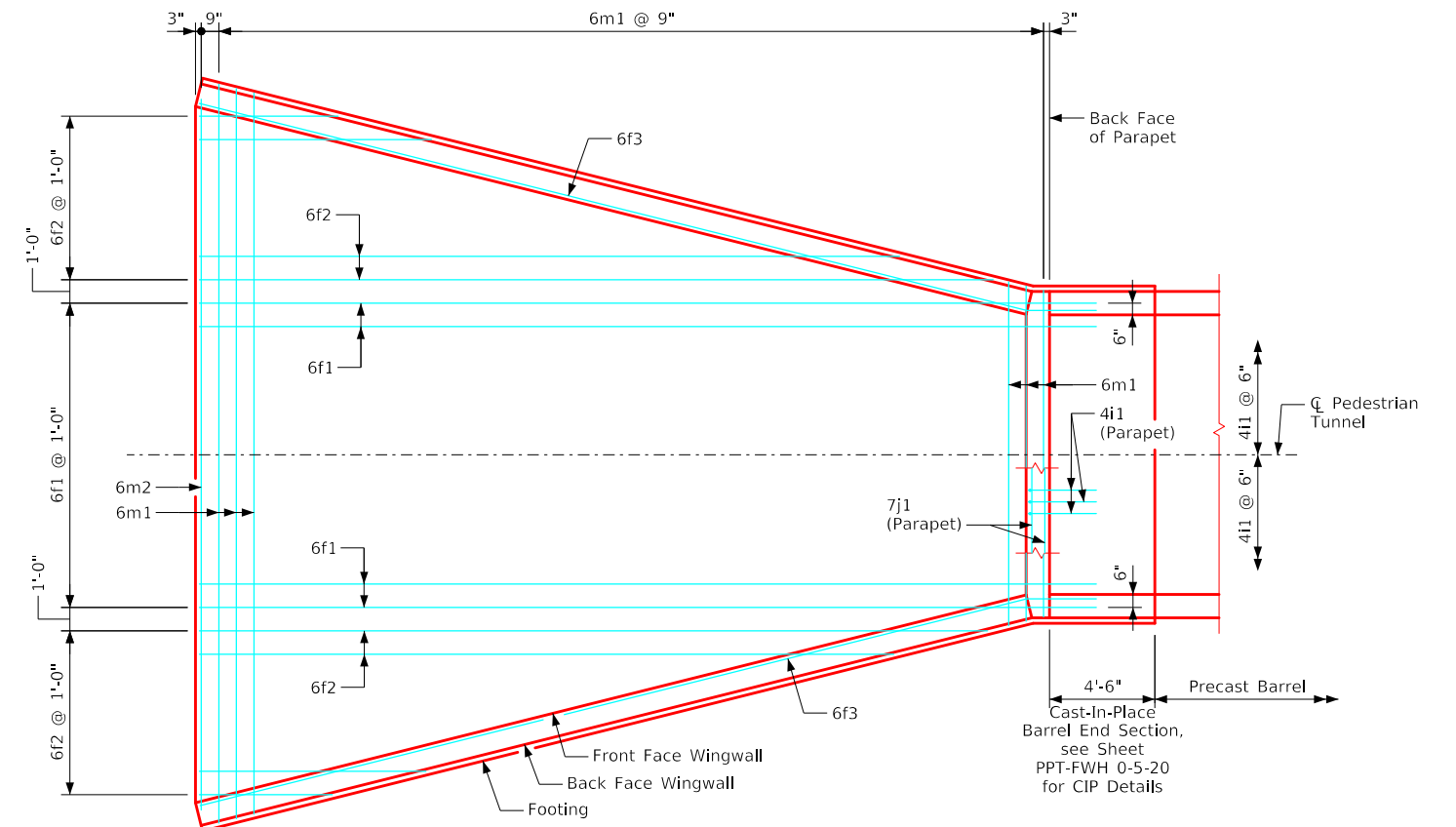

Plan View - Top of Apron Reinforcing Bars  
(Paving Notch Not Shown for Clarity)

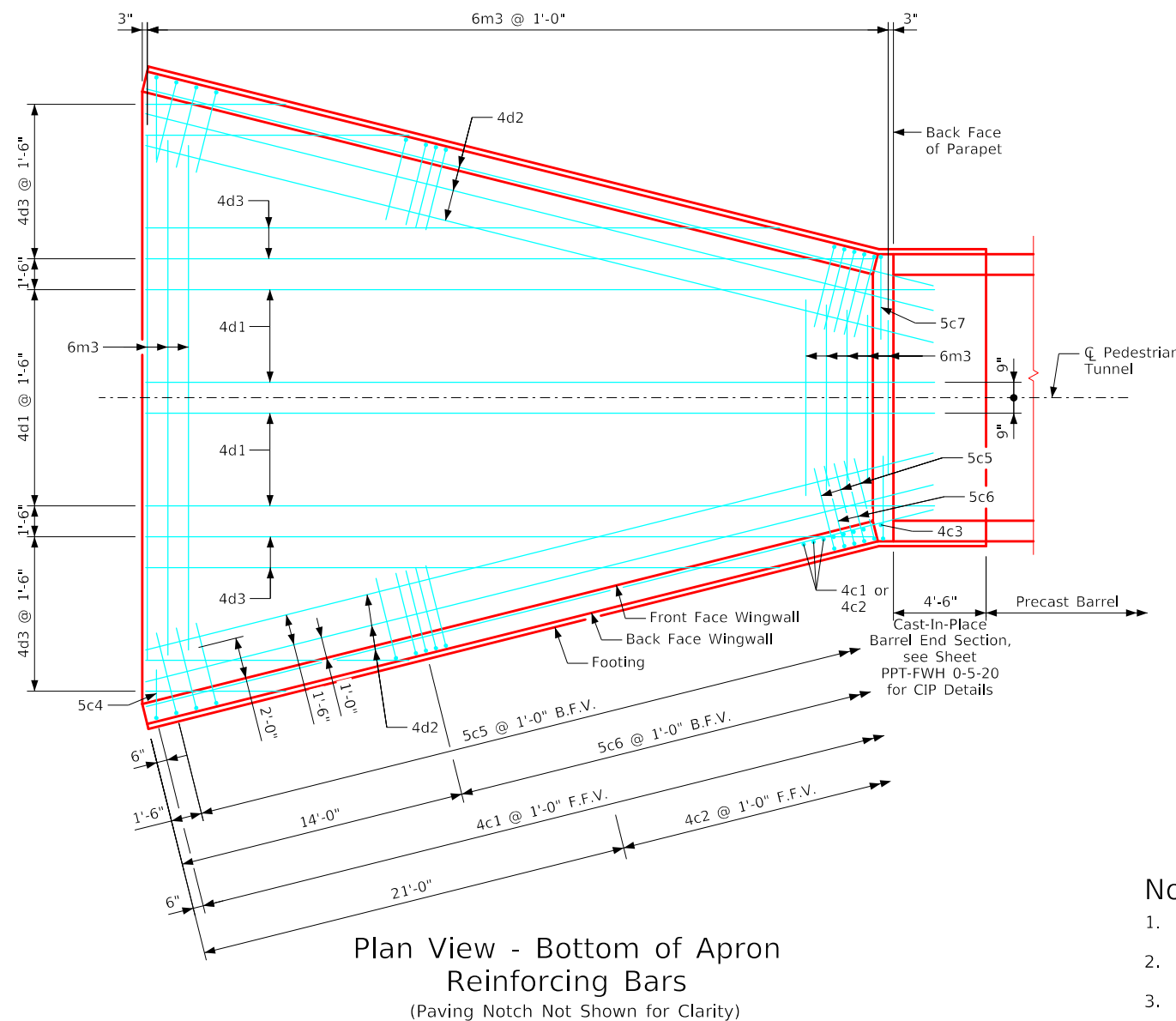

Plan View - Bottom of Apron Reinforcing Bars  
(Paving Notch Not Shown for Clarity)

**Class 20 Excavation for Paving Notch**

S x H2	Quantity (CY)
14' x 11'-10"	9.6
12' x 11'-10"	9.1
12' x 10'-10"	8.7

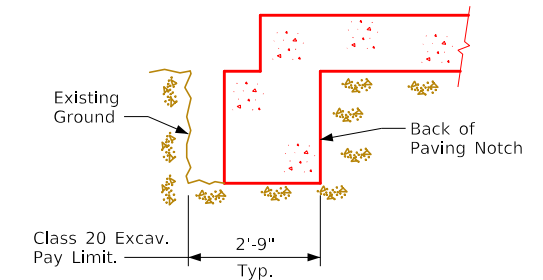

Paving Notch Class 20 Excavation

**Notes:**

1. Bar spacings and positions shown are similar for all sizes of headwalls in this standard.
2. Wingwall bars consistently referenced from end of wing for all headwalls.
3. For dimension table see Sheet PPT-FWH 0-1-20.

LATEST REVISION DATE	 APPROVED BY BRIDGE ENGINEER	 Precast Standard Design - Walkways and Trails <b>Precast Reinforced Concrete Pedestrian Tunnel</b> August, 2020	
		Flared Wing Headwalls 0° Skew	PPT-FWH 0-2-20

ENGLISH\_LRFD\_SIGNED\_PRECAST\_PEDESTRIAN\_TUNNEL\_STANDARDS.DGN - PPT-FWH 0-3-20 - THIS SHEET ISSUED 08-2020

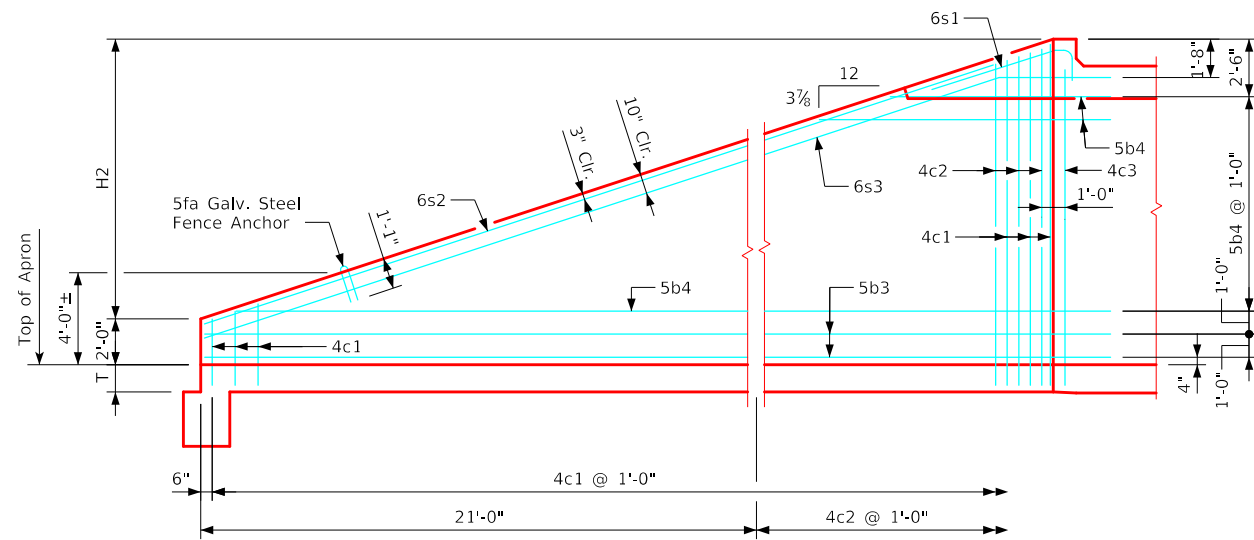

Typical View - Front Face Reinforcing

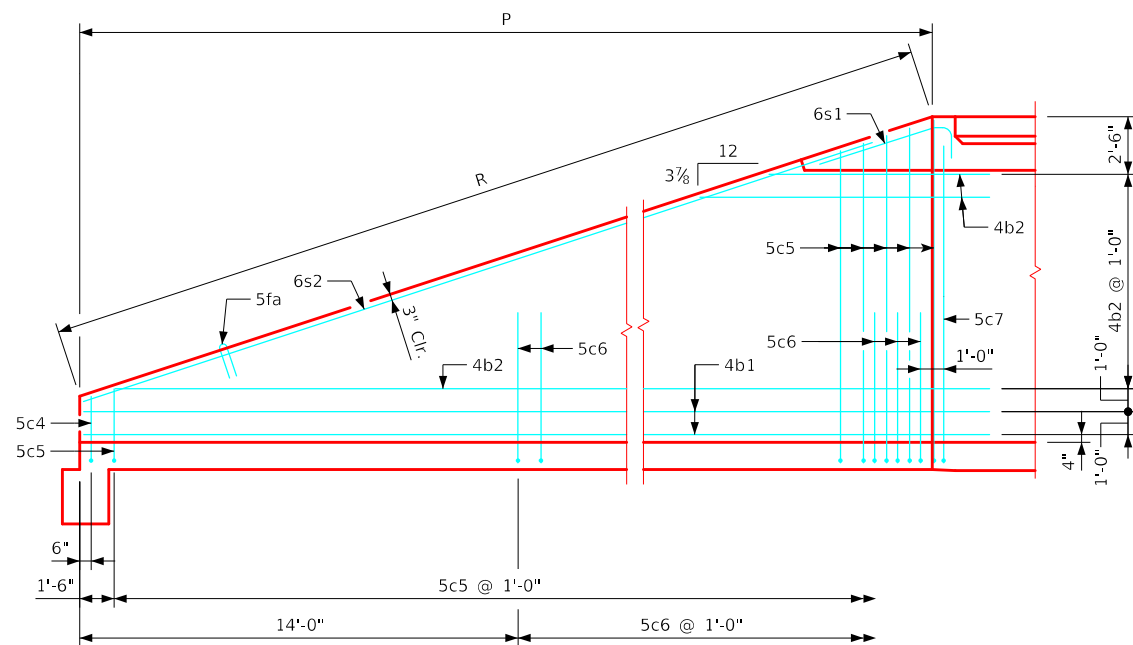

Typical View - Back Face Reinforcing

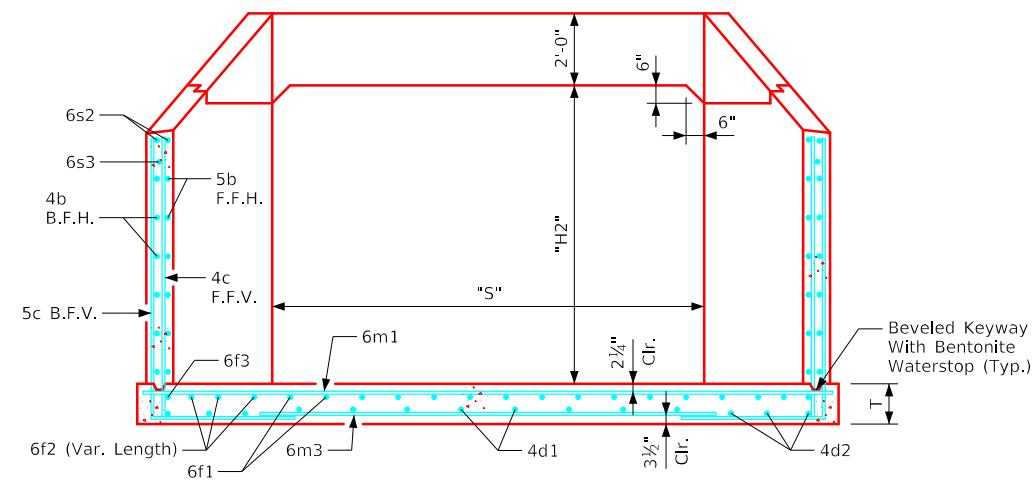

Typical Section - Near Center of Apron

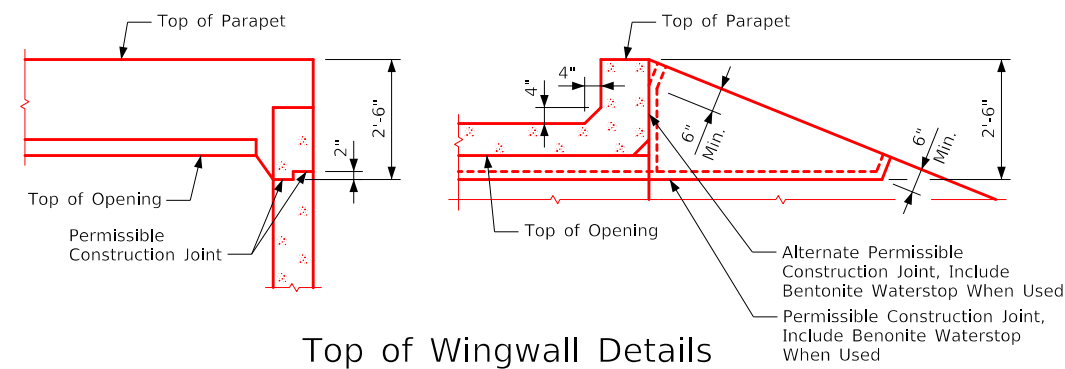

Top of Wingwall Details

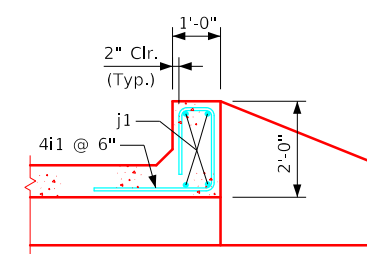

Section thru Parapet

Notes:

1. Bar spacing and positions shown are similar for all sizes of headwall in this standard.
2. For dimension table see Sheet PPT-FWH 0-1-20.

LATEST REVISION DATE	 APPROVED BY BRIDGE ENGINEER	 Precast Standard Design - Walkways and Trails <b>Precast Reinforced Concrete Pedestrian Tunnel</b> August, 2020	
		Flared Wing Headwalls	PPT-FWH 0-3-20
		0° Skew	



Reinforcing for One Headwall 0° Skew													
Location	Shape	14' x 11'-10"				12' x 11'-10"				12' x 10'-10"			
		Bar	No.	Length	Wt.	Bar	No.	Length	Wt.	Bar	No.	Length	Wt.
Fence Anchor (Galv.)		5fa	2	2'-10"	6	5fa	2	2'-10"	6	5fa	2	2'-10"	6
Wingwall, B.F.H.		4b1	4	39'-8"	106	4b1	4	39'-8"	106	4b1	4	36'-7"	98
Wingwall, B.F.H.		4b2	20 Var.	2 Each 10'-5 to 38'-3	325	4b2	20 Var.	2 Each 10'-5 to 38'-3	325	4b2	18 Var.	2 Each 10'-5 to 35'-2	274
Wingwall, F.F.H.		5b3	4	39'-9"	166	5b3	4	39'-9"	166	5b3	4	36'-8"	153
Wingwall, F.F.H.		5b4	20 Var.	2 Each 10'-6 to 38'-4	509	5b4	20 Var.	2 Each 10'-6 to 38'-4	509	5b4	18 Var.	2 Each 10'-6 to 35'-3	429
Wingwall, F.F.V.		4c1	74 Var.	2 Each 2'-10 to 14'-5	426	4c1	74 Var.	2 Each 2'-10 to 14'-5	426	4c1	68 Var.	2 Each 2'-10 to 13'-6	371
Wingwall, F.F.V.		4c2	32 Var.	2 Each 9'-6 to 14'-4	255	4c2	32 Var.	2 Each 9'-6 to 14'-4	255	4c2	26 Var.	2 Each 9'-6 to 13'-4	198
Wingwall, F.F.V.		4c3	2	13'-7"	18	4c3	2	13'-7"	18	4c3	2	12'-7"	17
Wingwall, B.F.V.		5c4	2	5'-2"	11	5c4	2	5'-2"	11	5c4	2	5'-2"	11
Wingwall, B.F.V.		5c5	72 Var.	2 Each 7'-2 to 18'-5	961	5c5	72 Var.	2 Each 7'-2 to 18'-5	961	5c5	66 Var.	2 Each 7'-2 to 17'-6	849
Wingwall, B.F.V.		5c6	46	10'-6"	504	5c6	46	10'-6"	504	5c6	40	10'-6"	438
Wingwall, B.F.V.		5c7	2	17'-7"	37	5c7	2	17'-7"	37	5c7	2	16'-7"	35
Apron, Longit., Bott.		4d1	10	38'-9"	259	4d1	8	38'-9"	207	4d1	8	35'-9"	191
Apron, Longit., Bott.		4d2	6	39'-10"	160	4d2	6	39'-10"	160	4d2	6	36'-9"	147
Apron, Longit., Bott.		4d3	12 Var.	2 Each 4'-8 to 34'-8	158	4d3	12 Var.	2 Each 6'-8 to 36'-8	174	4d3	10 Var.	2 Each 9'-4 to 33'-4	143
Apron, Longit., Top		6f1	16	38'-9"	931	6f1	14	38'-9"	815	6f1	14	35'-9"	752
Apron, Longit., Top		6f2	16 Var.	2 Each 5'-8 to 33'-8	473	6f2	16 Var.	2 Each 5'-8 to 33'-8	473	6f2	14 Var.	2 Each 6'-4 to 30'-4	386
Apron, Longit., Top		6f3	2	39'-4"	118	6f3	2	39'-4"	118	6f3	2	36'-3"	109
Parapet, Vertical		4i1	29	6'-1"	118	4i1	25	6'-1"	102	4i1	25	6'-1"	102
Parapet, Horizontal		9j1	4	15'-8"	213	7j1	4	13'-8"	112	7j1	4	13'-6"	110
Apron, Trans., Top		6m1	48 Var.	15'-10 to 33'-5	1775	6m1	48 Var.	13'-10 to 31'-5	1631	6m1	44 Var.	13'-8 to 29'-9	1435
Apron, Trans., Top		6m2	1	32'-1"	48	6m2	1	30'-1"	45	6m2	1	28'-7"	43
Apron, Trans., Bott.		6m3	37 Var.	9'-6 to 27'-6	1028	6m3	37 Var.	7'-6 to 25'-6	917	6m3	34 Var.	7'-6 to 24'-0	804
Paving Notch, Horizontal		5p1	4	32'-1"	134	5p1	4	30'-1"	126	5p1	4	28'-7"	119
Paving Notch, Horizontal		5p2	3	31'-5"	98	5p2	3	29'-5"	92	5p2	3	27'-11"	87
Wing Slope, Both F.		6s1	4	7'-8"	46	6s1	4	7'-8"	46	6s1	4	7'-8"	46
Wing Slope, Both F.		6s2	4	35'-11"	216	6s2	4	35'-11"	216	6s2	4	32'-8"	196
Wing Slope, F.F.		6s3	2	41'-7"	132	6s3	2	41'-7"	132	6s3	2	38'-4"	115
Paving Notch, Vertical		5t1	26	5'-2"	140	5t1	24	5'-2"	129	5t1	23	5'-2"	124
Paving Notch, Hoops		4t2	26	7'-7"	132	4t2	24	7'-7"	122	4t2	23	7'-7"	117
Estimated Quantities One Headwall	Reinf. Steel	9503 LB				8941 LB				7905 LB			
	Concrete	Parapet Δ	2.3		2.2		2.1						
		Wingwalls	21.2	68.9 CY	21.2	65.3 CY	16.6	56.0 CY					
		Apron	45.4		41.9		37.3						

Notes:  
Weight of bars over 40'-0" long includes an allowance of 2'-5" for lap.  
Lengths shown for bars over 40'-0" long do not include lap.

Δ Includes top of wingwall quantities.

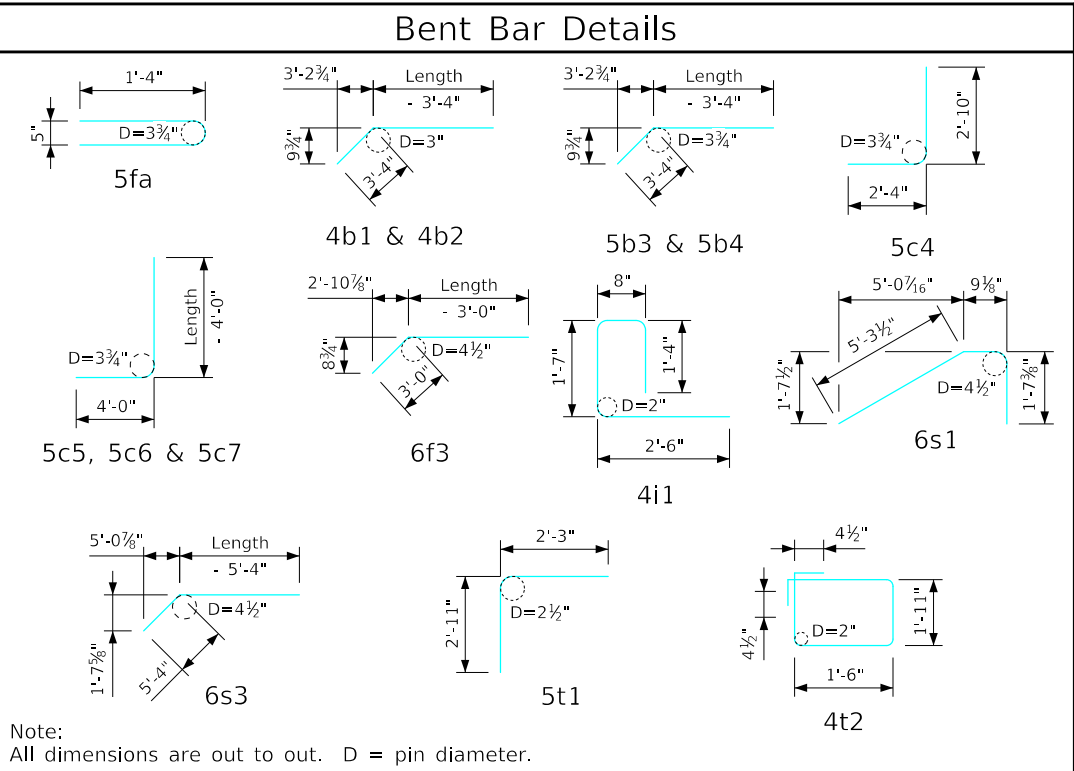

### Headwall Notes:

- See Sheet PPT G1-20 for General Information, Specifications, and Design Stresses.
- This headwall is based on a 3:1 slope normal to centerline of roadway.
- The sides of the apron are to be formed to ensure correct line and grade.
- All slab and apron reinforcing steel is to be supported by bar chairs at intervals of not more than 3'-0" in either direction as outlined in the Standard Specifications.
- Clear distance from face of concrete to near reinforcing bar is to be 2" unless otherwise noted or shown. Clearance to the bottom ends of vertical bars shall be 3 inches.
- Concrete quantities are estimated from back of parapet.
- Horizontal tails of bars "b" & "s" estimated to extend 2'-5" beyond back of parapet (into end of barrel). Longitudinal bars "d" and "f" estimated to project into end section of barrel a minimum of 2'-5" beyond back of parapet. The "Length" column reflects total number of feet necessary to meet these requirements.
- Dimensions are in feet and inches unless otherwise noted or shown.

LATEST REVISION DATE	 APPROVED BY BRIDGE ENGINEER	 Precast Standard Design - Walkways and Trails <b>Precast Reinforced Concrete Pedestrian Tunnel</b> August, 2020	
		<b>Flared Wing Headwalls</b> 0° Skew	<b>PPT-FWH</b> <b>0-4-20</b>

ENGLISH\_LRFD\_SIGNED\_PRECAST\_PEDESTRIAN\_TUNNEL\_STANDARDS.DGN - PPT-FWH 0-5-20 - THIS SHEET ISSUED 08-2020

### Reinforcing for One Barrel End Section

Bar	Location	Shape	14' x 11'-10"			12' x 11'-10"			12' x 10'-10"		
			No.	Length	Wt.	No.	Length	Wt.	No.	Length	Wt.
5a1	Barrel End Section Walls, F.F.V.		18	13'-8"	257	18	13'-7"	255	18	12'-6"	235
4b5	Barrel End Section Walls, F.F.H. & B.F.H.		46	4'-4"	133	46	4'-4"	133	42	4'-4"	122
5e1	Barrel End Section Slab, Bott. Longit.		13	4'-4"	59	11	4'-4"	50	11	4'-4"	50
4e2	Barrel End Section Slab, Top Longit.		12	4'-4"	35	10	4'-4"	29	10	4'-4"	29
4f4	Barrel End Section Floor, Top Longit.		15	4'-4"	43	13	4'-4"	38	13	4'-4"	38
4f5	Barrel End Section Floor, Bott. Longit.		12	4'-4"	35	10	4'-4"	29	10	4'-4"	29
6k1	Barrel End Section Slab, Bott. Transv.		9	15'-8"	212	9	13'-8"	185	9	13'-6"	182
5k2	Barrel End Section Slab, Top Corner		18	12'-10"	241	18	11'-10"	222	18	11'-10"	222
6m4	Barrel End Section Floor, Top Transv.		9	16'-2"	219	9	14'-2"	192	9	14'-0"	189
5m5	Barrel End Section Floor, Bott. Corner		18	19'-10"	372	18	19'-5"	365	18	18'-4"	344
3p1	Barrel Haunch		10	3'-9"	14	10	3'-9"	14	10	3'-9"	14
5z1	Dowel Reinforcing Bars		54	2'-6"	141	50	2'-6"	130	48	2'-6"	125
Reinf. Steel			1761 LB			1642 LB			1579 LB		
Estimated Concrete Quantities one Barrel End Section			Slab	3.2	10.3 CY	2.8	9.4 CY	2.8	8.6 CY		
			Floor	3.4		2.9		2.8			
			Walls	3.7		3.7		3.0			

### Bent Bar Details

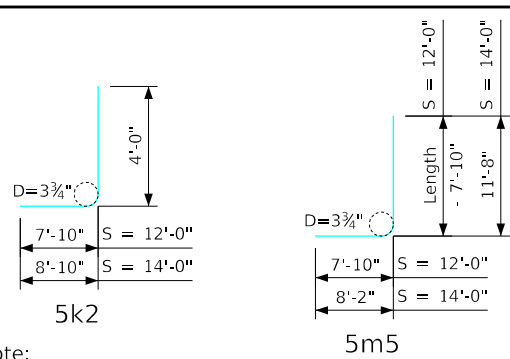

Note: All dimensions are out to out. D = pin diameter.

### Dimension Table

S x H2	14' x 11'-10"	12' x 11'-10"	12' x 10'-10"
D	12.5"	12"	12"
E	15"	14.5"	14"
F	12"	12"	11"

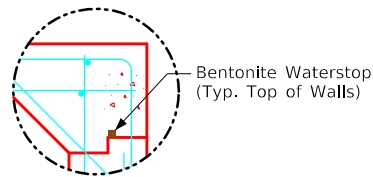

Detail A

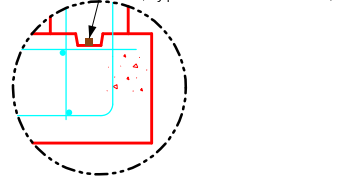

Detail B

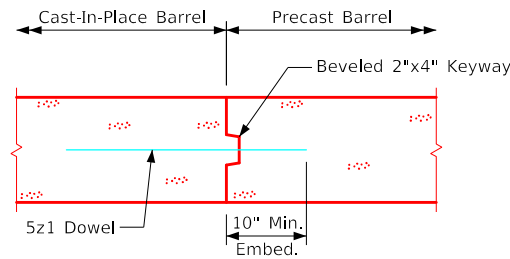

Joint Detail at Cast-In-Place Barrel Connection

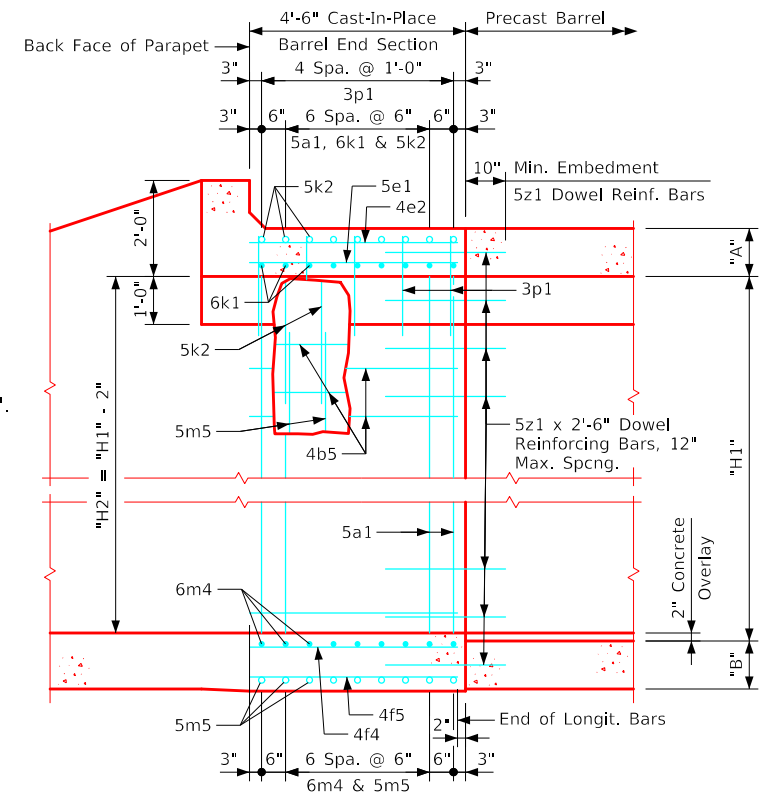

Part Longitudinal Section  
(Along C Culvert)

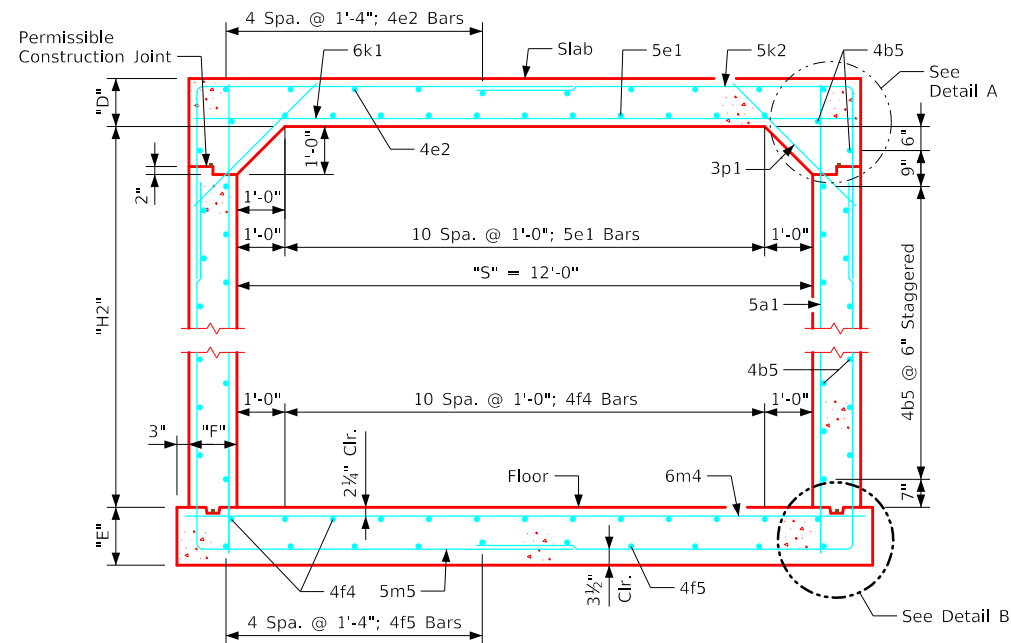

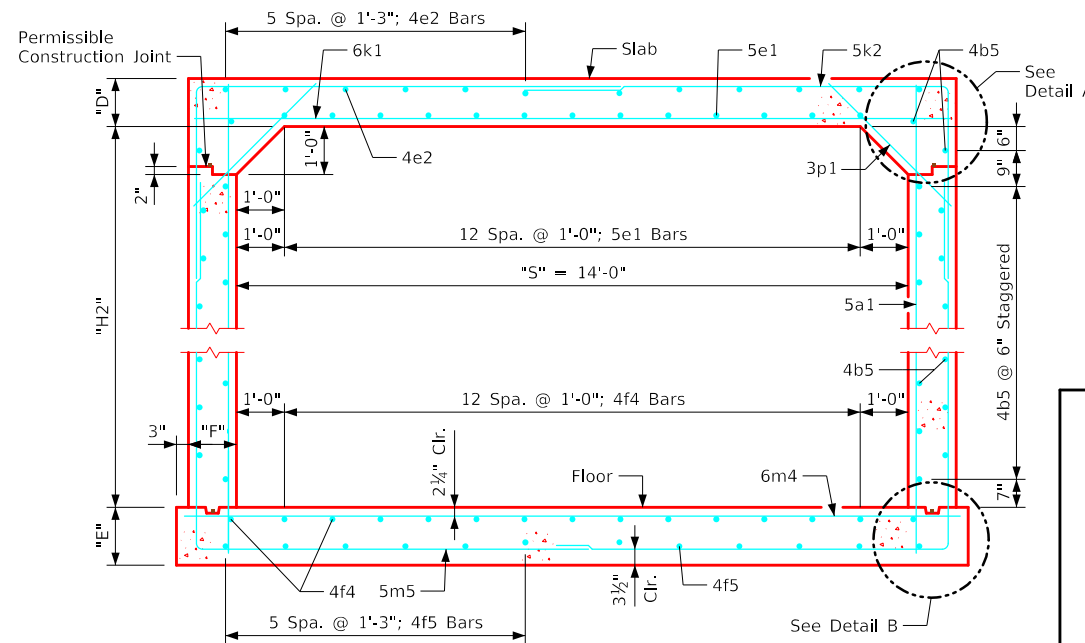

Barrel End Section - "S" = 12'-0"

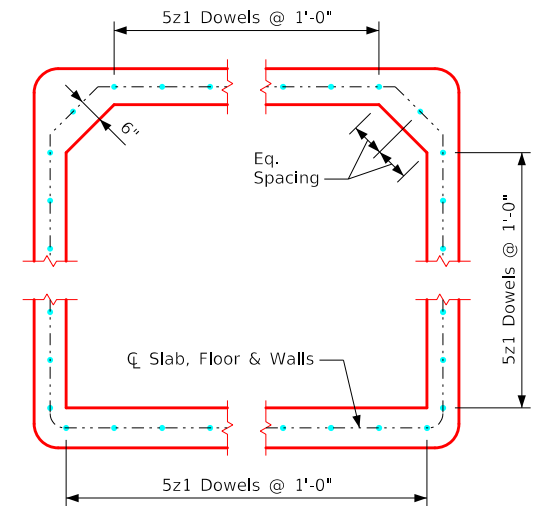

Barrel End Section - "S" = 14'-0"

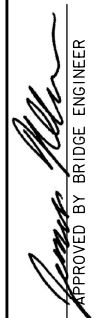

Part Precast Barrel Section  
(Showing Dowel Placement)

LATEST REVISION DATE	 APPROVED BY BRIDGE ENGINEER	 Precast Standard Design - Walkways and Trails <b>Precast Reinforced Concrete Pedestrian Tunnel</b> August, 2020	
		Barrel End Sections	PPT-FWH 0-5-20
		0° SKEW	

ENGLISH\_LRFD\_SIGNED\_PRECAST\_PEDESTRIAN\_TUNNEL\_STANDARDS.DGN - PPT-SR 1-20 - THIS SHEET ISSUED 08-2020

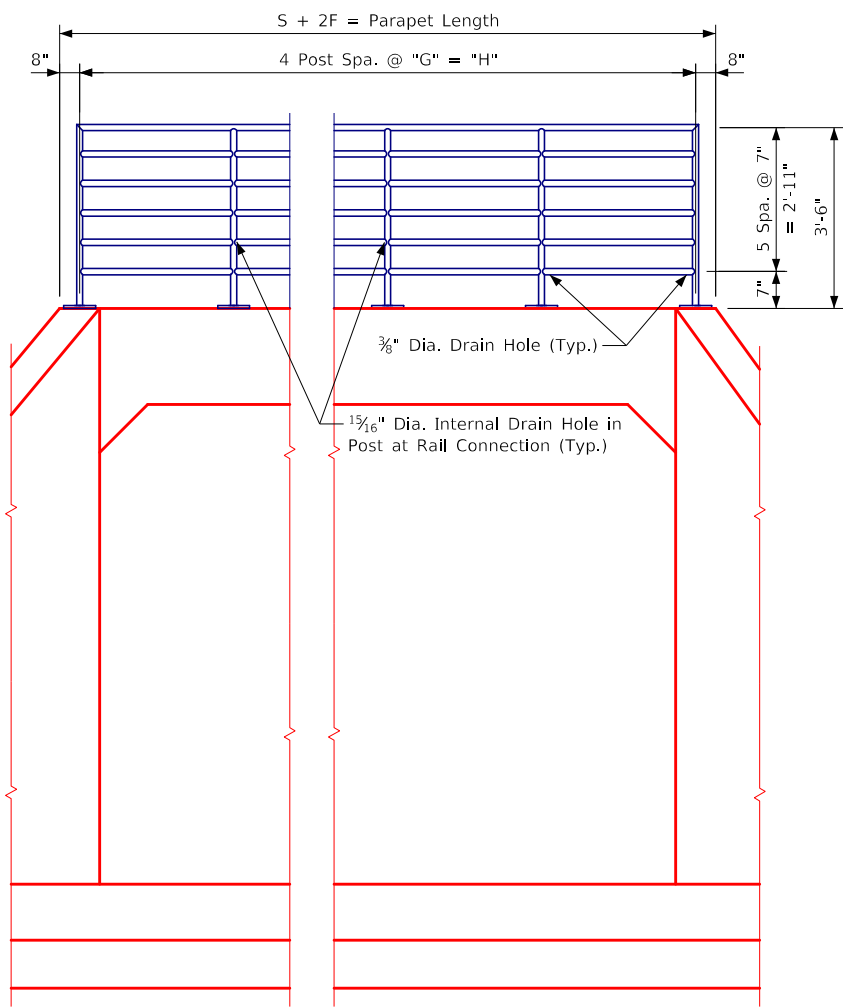

Partial End View of Parapet and Headwall

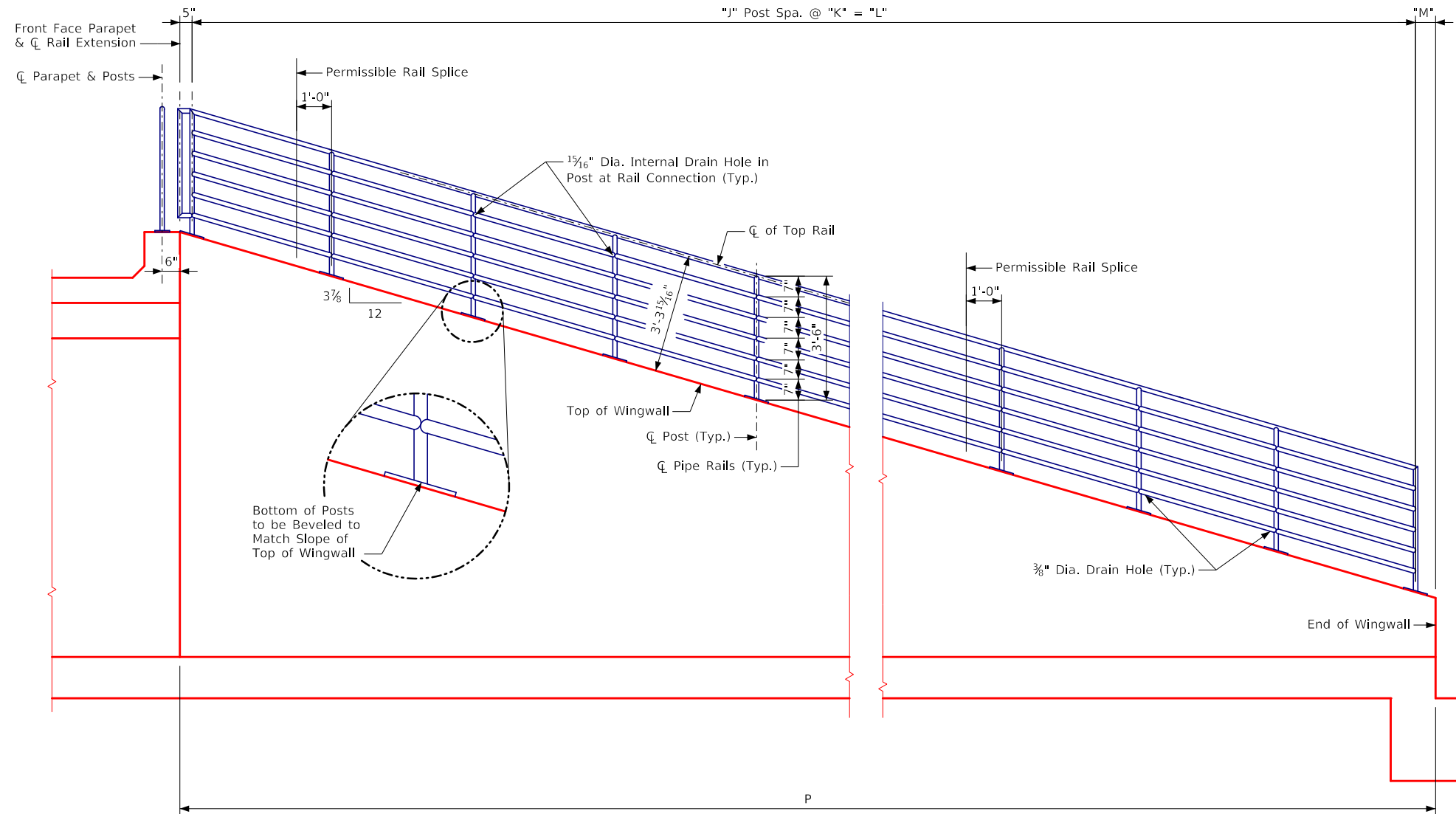

Elevation View of Wingwall

Safety Rail Dimension Table						
Headwall	"G"	"H"	"J"	"K"	"L"	"M"
12'-0" x 10'-10"	3'-1 1/2"	12'-6"	9	3'-7"	32'-3"	10"
12'-0" x 11'-10"	3'-2"	12'-8"	9	3'-11"	35'-3"	11 1/2"
14'-0" x 11'-10"	3'-8"	14'-8"	9	3'-11"	35'-3"	11 1/2"

Notes:

1. Total linear feet quantity of "Steel Pipe Pedestrian Handrail" provided on the "Estimated Quantities Table" in the design plans.
2. Post bases to be installed, centered on top of wingwalls and parapet and spaced as shown.
3. See Sheet PPT-FWH 0-1-20 for Dimension P.
4. See Sheet PPT-FWH 0-5-20 For Dimensions F & S.

LATEST REVISION DATE	 APPROVED BY BRIDGE ENGINEER	 Precast Standard Design - Walkways and Trails Precast Reinforced Concrete Pedestrian Tunnel August, 2020	
		Safety Rail Details	PPT-SR 1-20

ENGLISH\_LRFD\_SIGNED\_PRECAST\_PEDESTRIAN\_TUNNEL\_STANDARDS.DGN - PPT-SR 2-20 - THIS SHEET ISSUED 08-2020

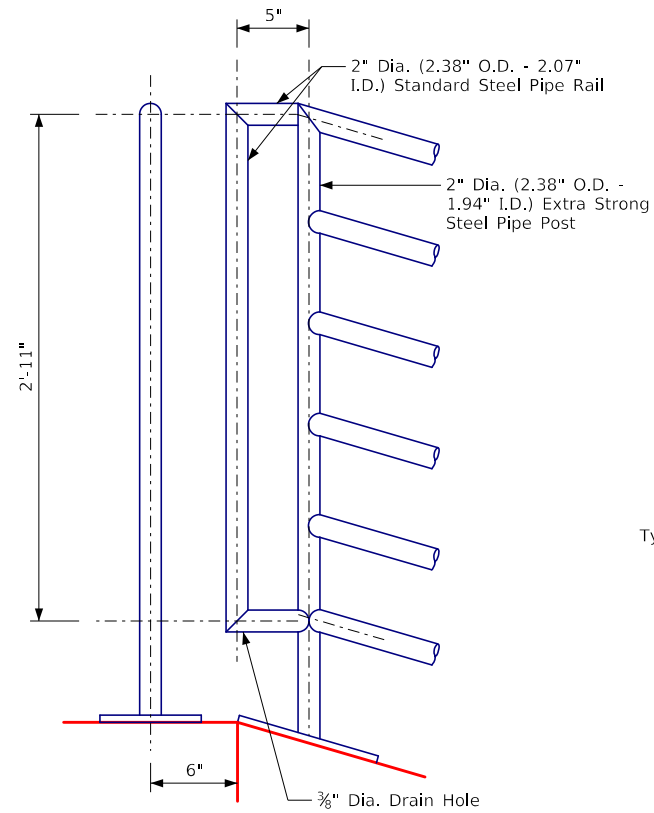

End Rail Details

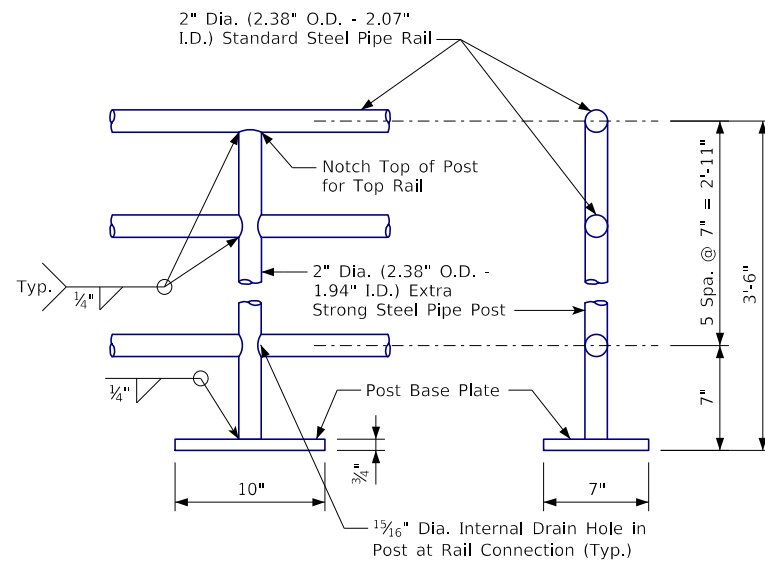

Pipe Handrail Details

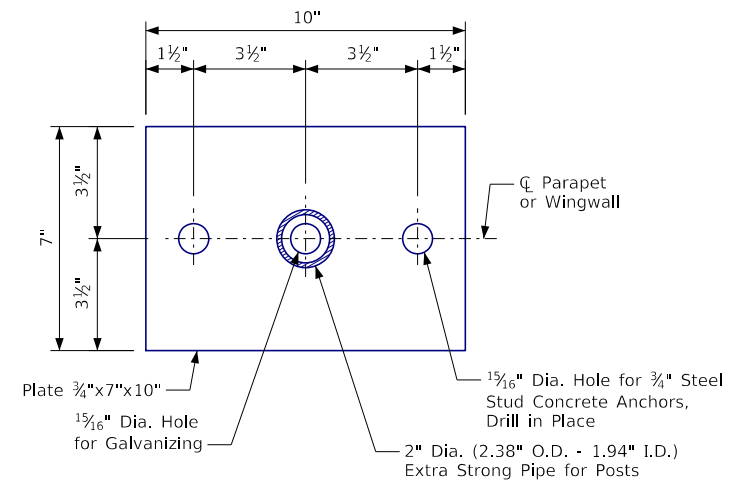

Post Base Plate and Shim Details

Note:  
Pipe handrail assembly to be galvanized after fabrication. Drilled-in drain holes, to facilitate the hot dip galvanizing process, shall be indicated on the shop drawings.

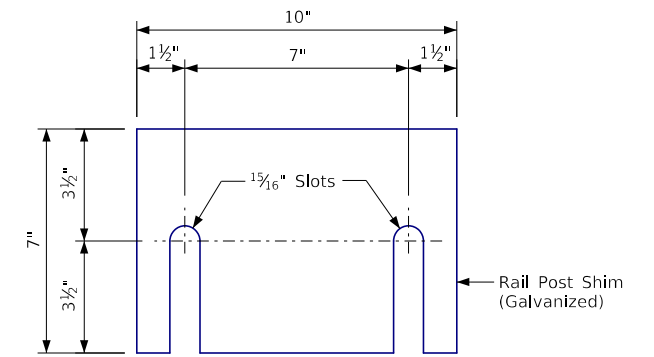

Note:  
Provide 1/16 inch galvanized steel shim at each rail post. Use as required.

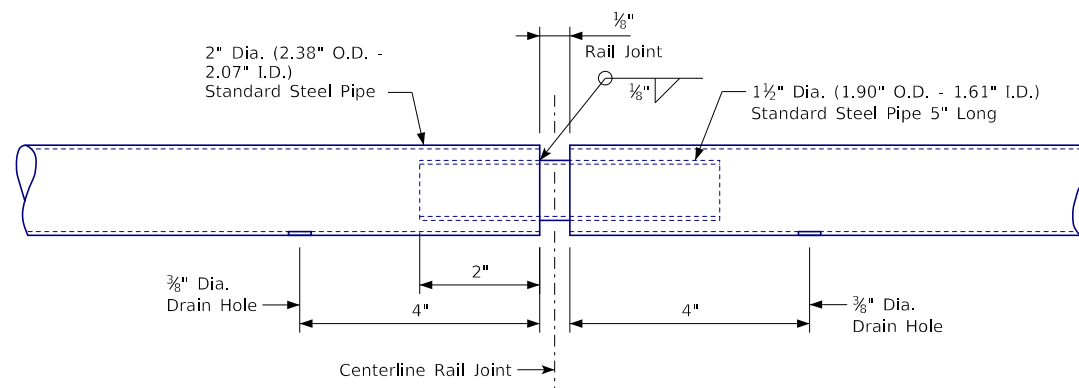

Rail Joint Detail

**Pedestrian Hand Rail Notes:**

1. The steel pipe pedestrian hand rail is to be bid on a linear foot basis measured end to end of rail. The price bid for "Steel Pipe Pedestrian Handrail" shall be full compensation for furnishing all material, including anchor bolts and shims, and all of the equipment and labor required to erect the rail in accordance with these Plans and Specifications.
2. The material for tube rails, posts and splice tubes shall be standard and extra strong steel pipe meeting the requirements of ASTM A53, Type E or S, Grade B. Base plates and shims shall meet the requirements of ASTM A36. Panels and end sections shall be galvanized, after fabrication, in accordance with the requirements of ASTM A123.
3. Ends of rail sections are to be sawed or milled. All cut ends are to be true, smooth, and free of burrs or ragged edges.
4. No painting will be required.
5. The stud concrete anchors shall be galvanized and have a minimum pull out strength of 8000 pounds based on 4000 PSI concrete.
6. Rail is to be centered along the centerline of wingwalls and parapets.
7. Posts shall be set plumb.

LATEST REVISION DATE	APPROVED BY BRIDGE ENGINEER	<b>IOWA DOT</b>	
		Precast Standard Design - Walkways and Trails <b>Precast Reinforced Concrete Pedestrian Tunnel</b> August, 2020	
		Safety Rail Details	PPT-SR 2-20

### General Notes for Textured Concrete Form Liners:

1. See individual design sheets for specific notes and details describing the features which incorporate textured concrete. Work performed to create textured concrete shall be in accordance with the Standard Specifications for formwork and the following:
2. Form the textured concrete surface using a form liner system made of high-strength urethane elastomer, plastic or flexible foam materials capable of withstanding anticipated concrete pour pressures without leakage or causing physical defects. Form liners shall easily attach to forms and be removable without causing concrete surface damage. If recommended by the form liner Manufacturer, use structural backers to prevent deformation of the liner during loading of the forms. The liners shall be designed to form surfaces conforming to the design intent including the shape, lines and dimensions shown in the plans and to avoid visible pattern repeats. Match pattern features at form liner joints to minimize pattern repeats and make the formed concrete surface appear uniform and continuous without visible seams and form marks. When joints are unavoidable, make joints along main features of the pattern in accordance with Manufacturer's recommendations.
3. Form liner edges following curves are to be cut cleanly and parallel to the curve. Use adequate blocking, sealing and other means in order to maintain the appropriate depth and character of texture at cut edges of liners and to prevent mortar leakage.
4. During loading of forms with concrete, take extra care to adequately vibrate concrete in order to maintain all intended features of the form liner in the final surface and to prevent voids. Following removal of forms, finish minor defects to blend with the balance of the surface texture. The completed surface shall be free of blemishes, surface voids and conspicuous form marks to the satisfaction of the Engineer. The Contractor shall correct, at his own cost, any surface defects.
5. Verify that release agents used are compatible with form liner material, and are non-staining. Apply release agent in accordance with the form liner Manufacturer's recommendations.
6. If used, form ties shall be made of non-corrosive materials when the portion permanently embedded in the concrete is less ties and accessories in stone pattern mortar joints and at high points of finished wall.
7. If heating forms during cold weather construction, take special care to avoid damaging form liners. Overheating can warp or melt some form liner materials.
8. Strip formwork using techniques in accordance with liner manufacturer's recommendations after the concrete has achieved the strengths and cure times required by the plans and applicable Specifications. Clean and repair form liner surfaces prior to use. Do not use split, frayed, delaminated or otherwise damaged form liners.
9. All costs associated with concrete texturing and form liners are to be included in the bid item "Structural Concrete (RCB Culvert)".

### General Notes for Concrete Rustication:

1. Strips and panels used as inserts within concrete forms to create the rustication features may be made of wood, steel, plastic or other nonporous material capable of withstanding anticipated concrete pour pressures without physical defects. Wood inserts, if used, shall be free of warp, twist, checks or cracks, and shall be presoaked prior to placement of concrete in the forms.
2. Rustication inserts shall easily attach to forms and shall not allow leakage of concrete between the form and the insert. When steel forms are used, rustication strips may be rigidly attached to the inside surfaces of the forms. When steel forms are not used, rustication strips and other inserts for small recesses on exposed concrete surfaces shall be fastened to the forms in a manner that will permit them to remain in place when the forms are removed. Leave inserts in place until they can be removed without damage to the surrounding concrete.
3. The inserts shall be designed to form surfaces and features conforming to the design intent including the shape, lines, depths and dimensions shown in the plans. Create inserts using a minimum number of splice joints in their length. Splices, if used, shall be tightly joined so as not to allow gaps or leaks, and shall not create any change in alignment or shape of the rustication feature. Do not locate form ties within concrete rustications.
4. For rustication features following the perimeter of rounded surfaces, it may be necessary to use multiple layers of insert material in order to achieve the radius curve. This is acceptable, provided that the final shape, line, depth, and dimension of the features are maintained in the final result.
5. During loading of forms with concrete, take extra care to ensure proper consolidation of concrete around all rustication inserts to preserve the shape, line and depth of all intended features in the final concrete surface. Following removal of forms, repair all defects to achieve the rustication features as specified in the plans. Patch voids, honeycomb areas, etc., in accordance with the Standard Specifications. If surfaces will not receive a colored sealer coating, add white cement to the patching mortar to lighten it in order to match surrounding concrete when dry. Completed surface shall be free from blemishes, surface voids and conspicuous form marks to the satisfaction of the Engineer. The Contractor shall correct, at his own cost, any surface defects.
6. All costs associated with concrete rustication are to be included in the bid item "Structural Concrete (RCB Culvert)".

### Anti-Graffiti Coating Notes:

1. Anti-graffiti surface preparation and application shall be in accordance with the "Special Provisions for Anti-Graffiti Coating" and material used shall be an approved type in accordance with Materials I.M. 491.23. Color shall be clear. Anti-graffiti coating must be compatible with other concrete coatings used on the project in accordance with the Manufacturer's recommendations.
2. Anti-graffiti coating shall be applied to all interior surfaces of the pedestrian tunnel except the walking surface, and all exposed vertical surfaces of the headwalls including the parapets. Anti-graffiti coating is not required on the top horizontal surfaces of the parapets. All costs for anti-graffiti coating shall be included in the bid item "Anti-Graffiti Coating" and is paid for on a square yard basis.

### Tunnel Concrete Coating Notes:

1. All interior surfaces of the pedestrian tunnel except the walking surface, to the limits of the front face of parapets, shall be finished with a 100% acrylic, vapor permeable masonry coating. The coating used shall be certified to allow water vapor transmission in accordance with ASTM E96 or ASTM D1653.
2. The 100% acrylic, vapor permeable masonry coating shall be one of the following listed products:
  - A. TK Products Tri-sheen Acrylic
  - B. Sherwin Williams A-100
  - C. Chemrex Inc. Thorosheen
  - D. Edison Coatings Aqryl-X 200
  - E. Approved equal; submit product information to the Iowa DOT, Bridges and Structures Bureau, Ames, IA 50010. Do not order materials prior to receiving approval for use on the project.
3. Prior to concrete coating application, prepare surfaces in accordance with the "Developmental Specifications for Concrete Surface Preparation and Testing Prior to Coating Application". Apply 100% acrylic, vapor permeable masonry coating in accordance with the "Developmental Specifications for Structural Concrete Coating".
4. One color of concrete coating is to be used on the pedestrian tunnel. The color shall be white matching SAE AMS-STD-595 color number 27925 (semi-gloss). Submit product specifications and color samples in accordance with the "Developmental Specifications for Structural Concrete Coating".
5. No coating overspray or other contamination shall be allowed on the floor surface of the pedestrian tunnel, on the adjacent parapets, headwalls, or on the approach pavement. Take special care to avoid contamination of adjacent surfaces.
6. All costs associated with surface preparation and application of 100% acrylic, vapor permeable masonry coating are to be included in the bid item "Structural Concrete Coating".

LATEST REVISION DATE	APPROVED BY BRIDGE ENGINEER		
		Precast Standard Design - Walkways and Trails Precast Reinforced Concrete Pedestrian Tunnel August, 2020	
		Aesthetic Treatment General Notes	PPT-AD 1-20



ENGLISH\_LRFD\_SIGNED\_PRECAST\_PEDESTRIAN\_TUNNEL\_STANDARDS.DGN - PPT-AD 2-20 - THIS SHEET ISSUED 08-2020

### Textured Concrete Notes:

1. This work consists of applying textured finishes on all designated concrete surfaces of the pedestrian tunnel headwalls shown in this plan. See "General Notes for Textured Concrete Form Liners" on sheet PPT-AD 1-20 for more information regarding the use of form liners. The textured concrete mockup panel must be reviewed and approved by the Engineer before beginning production concrete work that includes texture.
2. The form liner used to produce the texture shown in the plan details shall produce a textured effect of a realistic, random drystack stone masonry surface having stones of varying size and shape. Individual stone dimensions shall be between 3 and 42 inches. Maximum depth of texture shall be between 1½ and 2½ inches.
3. Obtain texture form liner materials from one of the following manufacturers:
  - A. Custom Rock International (Pattern Nos. 1203, 1208)
  - B. Fitzgerald Formliners (Pattern No. 17911)
  - C. Architectural Polymers (Pattern No. 911)
  - D. Other Manufacturers and patterns submitted to and approved by the Iowa Department of Transportation, Bridges and Structures Bureau.
4. The pedestrian tunnel headwall surfaces as designated in the plans shall also receive concrete rustication. See "General Notes for Concrete Rustication" on Sheet PPT-AD 1-20 for more information regarding approved techniques and methods of concrete rustication.

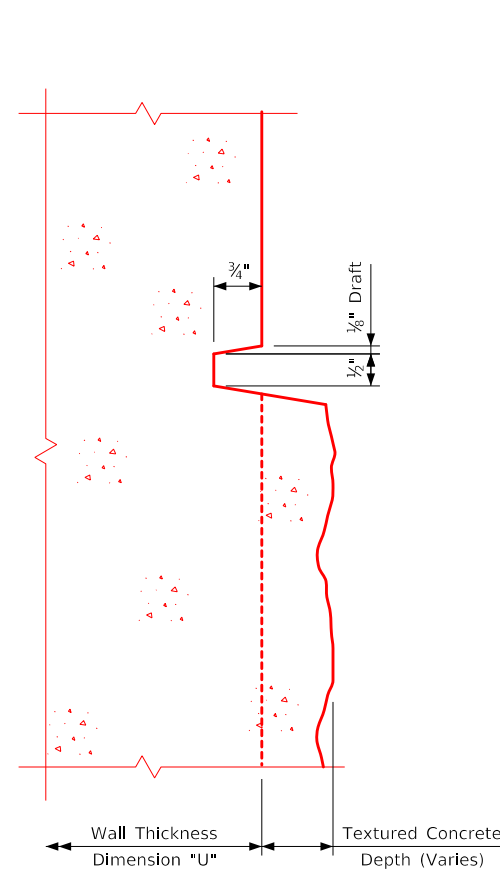

Section A-A

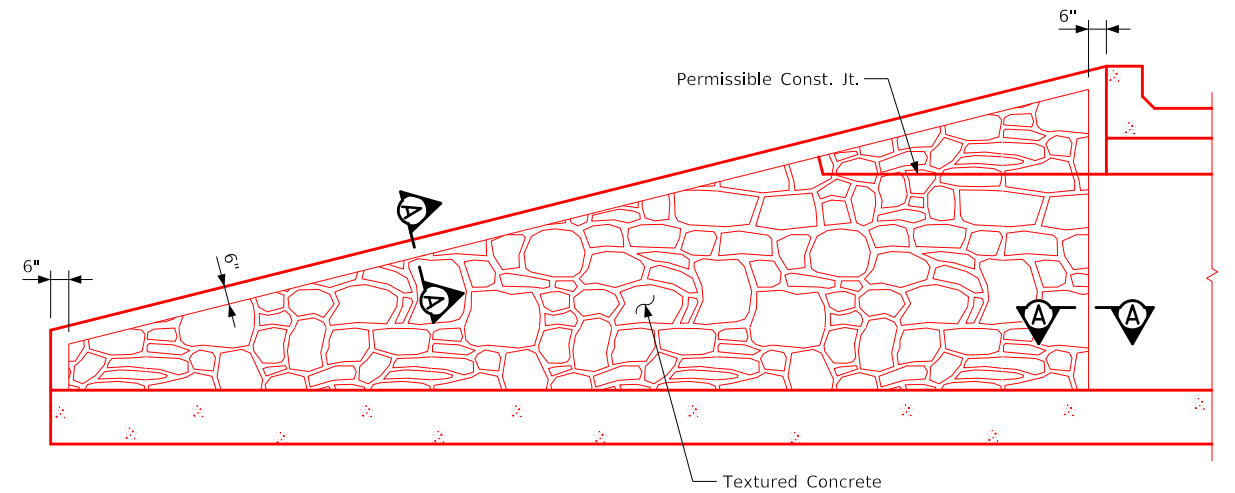

Typical Wingwall Elevation

### Texture Mockup Panel Notes:

1. Prior to beginning any production concrete work that includes texture, a textured concrete mockup panel must be reviewed and approved by the Engineer.
2. Construct a 3-foot high, by 6-inch wide (Min.), by 3-foot long mockup panel in accordance with the Standard Specifications and these plans. See mockup details on this design sheet.
3. Cast the mockup panel(s) on site, using the same forming methods, procedures, form liners, and concrete mixture(s) as are proposed for the production work. Textured face shall be vertical during the casting process. A single mat of No. 5 reinforcing bars in two directions shall be centered within the panel. If the mockup panel is rejected, construct a new mockup panel as directed by the Engineer. Begin textured concrete production work only after the mockup has been approved by the Engineer.
4. All costs associated with the textured concrete mockup panel(s) shall be included in the price bid for "Structural Concrete (RCB Culvert)".

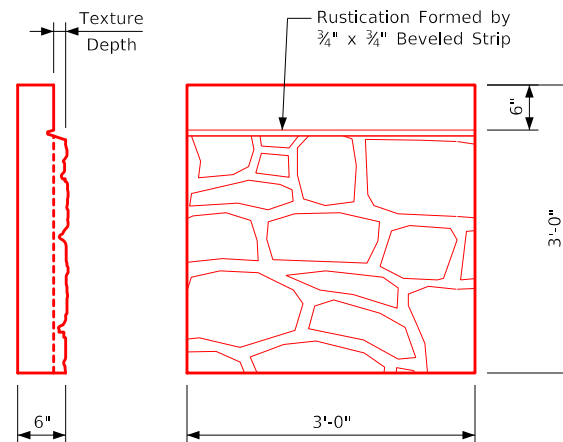

Texture Mockup Panel Details

Textured Concrete - One Headwall	
Location	Quantity (CY)
12' x 10'-10" Headwall	1.7
12' x 11'-10" Headwall	2.0
14' x 11'-10" Headwall	2.0

Note:  
Quantity is based on an average relief of 1¼" over the surface area of the wingwall.

LATEST REVISION DATE	 APPROVED BY BRIDGE ENGINEER	 Precast Standard Design - Walkways and Trails <b>Precast Reinforced Concrete Pedestrian Tunnel</b> August, 2020	
		Pedestrian Tunnel Textured Concrete	PPT-AD 2-20