

IX. Problems and Solutions

Segregation

(Specification 2303.03, C, 4;
Construction Manual sections 2.53 &
Appendix 2-34)

Segregation in hot mix asphalt is a non-uniform distribution of various aggregate sizes throughout the mass. The finished mat has a varied texture and may not meet specification requirements for surface texture, smoothness, or density. Severely segregated pavements require maintenance sooner than properly constructed ones because of excessive moisture damage, raveling, and premature cracking. The primary types of segregation include Truckload Interval, Random, and Longitudinal. Each type of segregation is the result of a specific action in mixing, delivery, and placement operations.



Truckload Interval Segregation

Truckload interval segregation may be seen as crescent or chevron shaped spots (sometimes called “wings”) at the beginning and ends of truckloads. This type of segregation has many potential causes. The most prevalent cause is improper loading of the haul truck at the plant. If mix is placed in the truck bed in one drop from the silo, the coarse aggregate particles in the mix have a tendency to run to both the front of the bed and to the back tailgate. The situation is aggravated by the plant operator continuously opening and closing the silo gates to dribble mix into the truck and “top off” the load. For a tandem-axle truck, this problem is solved by using multiple drops of mix:

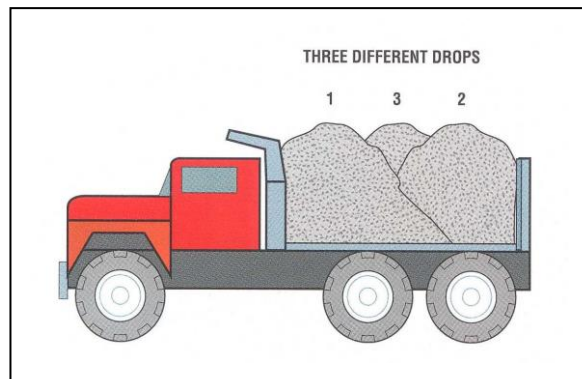

Chapter 9

First, into the front of the truck; then, into the back of the truck; and finally, into the center of the truck bed. Additional drops are made if a larger truck is used. Truck unloading, particularly by raising the truck bed slowly while dumping, can contribute to a segregation problem. The truck bed should be partially elevated before the tailgate is released. This permits the mix to move in mass and to flood the hopper, thus preventing the coarse aggregate from falling out first and causing spotty segregation patterns. Paver operation can also be a cause of load interval segregation. Dumping the paver wings, thus sending coarser material to the middle of the hopper, after running the paver dry and then moving forward before the hopper is recharged can create this form of segregation. If the paver wings are lifted, it should only be done slowly with other non-segregated material in the feeder area, and only enough to keep the mix in the wings “alive”. That is, the mix in the corners of the hopper should not be allowed to cool before being moved to the center of the hopper. This will give the coarse material an opportunity to blend with more homogenous material, thus minimizing the segregation effect. Never allow the paver operator to bang the hopper wings to loosen crusted mix!

Random Segregation

Random segregation consists of areas of coarse aggregate, sometimes referred to as “rock pockets”, that occur randomly across the length and width of the mat. Random segregation is often a result of improper handling of the aggregates in the stockpile and cold-feed bins at the hot mix asphalt plant. Rock pockets or random segregation

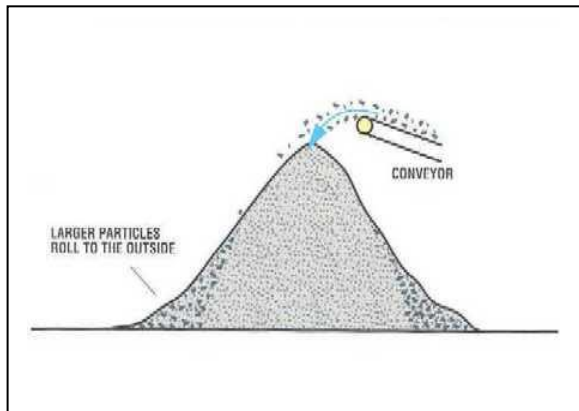

Chapter 9

can occasionally be found on the roadway when the mix is manufactured in a drum mix plant. If the loader operator places a bucketful of segregated aggregate in the cold-feed bin, that material can pass through the drum, surge silo, haul truck, and paver without being completely mixed in with the other aggregates. Random segregation seldom occurs with a batch plant, as the screens and hot bins recombine the segregated material before it is fed to the pugmill. The pugmill further blends the aggregates and eliminates any segregation that may have existed previously. Proper materials handling at the plant can greatly reduce the incidence of this form of segregation.

Longitudinal Segregation

Most longitudinal or continuous forms of segregation can be linked to the paver and, in particular, the material handling system. A longitudinal, segregated strip often develops in the center of the paved lane under the center screw conveyor (auger) support. Segregation is caused by a lack of material and the resulting coarse aggregate “roll down” into the center portion of the mat. This problem has been reduced in newer systems, which permit the conveyors to be raised, allowing unrestricted flow of material into the center area. Also, kickback paddles or reverse-flow augers may be incorporated to redirect mix to the center gearbox area. Following are other areas of the paver where segregation can be a problem: outside edges of the flight feeders, under the outboard screw conveyor supports, and the outer edges of the screed. Most segregation problems in these cases are due to a lack of material flowing to

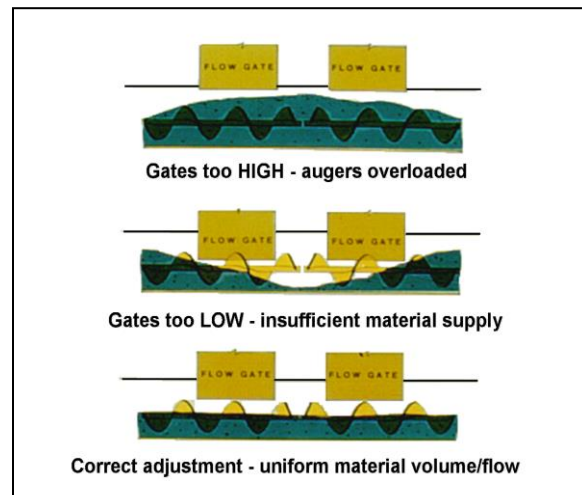
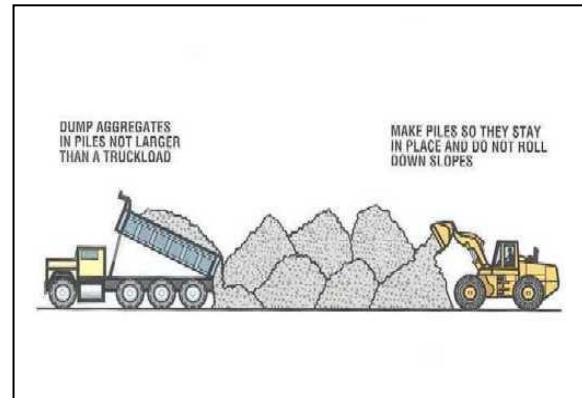

Chapter 9

the areas in question. This may be a result of excessive wear or improper adjustment of the paver's material handling components, combined with the inability of a particular mix to flow. The paver must be properly maintained and operated such that an adequate and consistent head of material is delivered to all locations.

Segregation is observed in the newly laid mat immediately behind the paver and after rolling. Drive a newly placed mat in the early morning, late evening, or when the mat is wet. Segregation may show up more clearly under these conditions. When you think segregation is evident, corrective action should be taken immediately. Notify the contractor and your immediate supervisor as soon as possible.

Construction Manual Appendix 2-34 (K.1) and Appendix 2-34(K.2) help define and give guidance for making segregation price adjustments.

“Temperature” Segregation

Temperature differentials in hot mix asphalt can lead to some of the same problems as mixture segregation. The temperature differentials, in transverse or longitudinal direction, may be caused by delays at the plant or in trucking operations. Improper paver operation and inconsistency in the placement process can also contribute to temperature gradients, especially across the width of the mat. These variations in mat temperature lead to inconsistent compaction, resulting in waves and poor ride quality. A lack of density in the cooler areas of the mat ultimately leads to premature deterioration of those pavement areas.

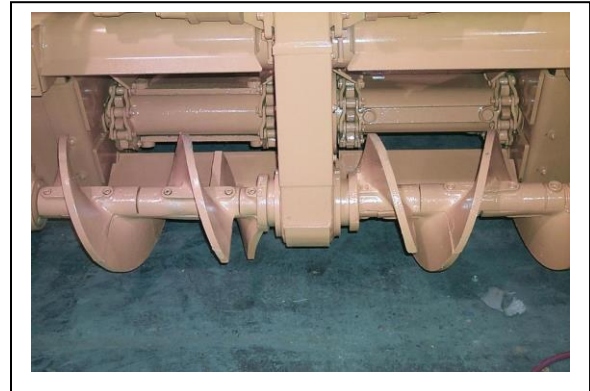
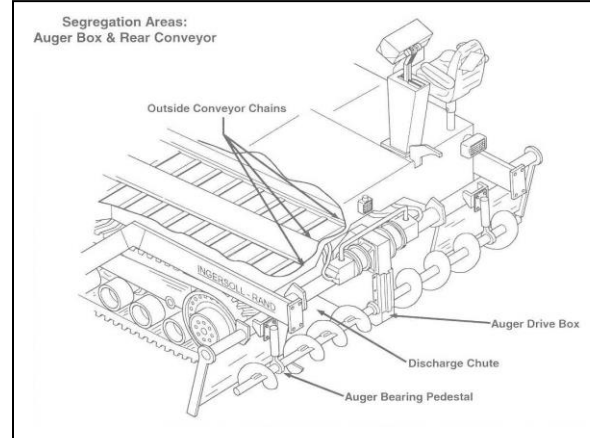

Chapter 9

The best way to avoid temperature segregation is with a consistent paving operation. Frequent temperature monitoring, both at the plant and behind the paver, may reveal sources of inconsistencies in mat temperature. Thermal imaging (infrared) cameras are available that can detect temperature gradients in freshly placed HMA. Though not specified in Iowa, some states do require use of infrared cameras to monitor consistency of mat temperature and quickly identify problems as they develop.

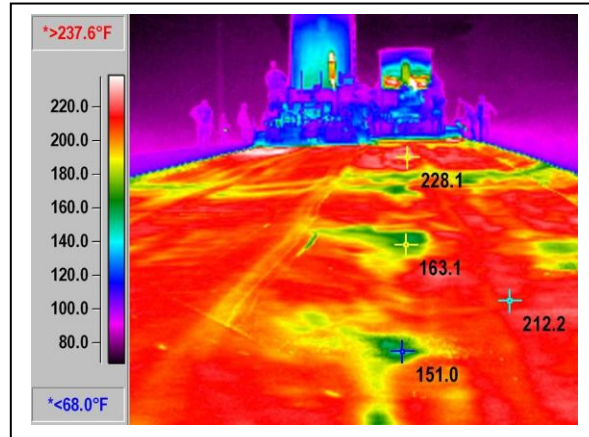

Tack Coat Application

As stated previously in this manual, the purpose of tack coat is to ensure a bond between the existing pavement surface and the new hot mix asphalt overlay. A good bond can increase the overall structural strength of the pavement and prevent intrusion of water between the layers. If a good bond is not formed between the existing surface and the new overlay, a slippage or sliding-type failure can occur.



Three main areas of emphasis have emerged in recent years that must be followed to ensure a tack coat has been properly applied and will likely function correctly: Tack Coat Application Rate, Uniform Tack Coat Application, and Breaking of Tack Coat.

Tack Coat Application Rate

The amount of tack coat applied to the surface to be overlaid is very important. Too little tack coat can result in no bond between pavement layers. Too much tack coat promotes slippage or sliding



between layers and bleeding of asphalt emulsion to the pavement surface. A pavement that is scarified (milled) requires more tack coat than other surfaces since this process creates more surface area to cover. Rates of application and other requirements for tack coats are given in the contract documents. Tack quantities provided daily by the contractor should be compared with the area covered to verify the rate of application.

Uniform Tack Coat Application

Proper tack coat application goes beyond simply applying the proper quantity of tack. The uniformity of the tack coat application also plays an important role and should not be overlooked.

The tack coat material, which is normally asphalt emulsion, should be uniformly heated to the proper temperature so that it may be sprayed from properly functioning nozzles and not come out in strings. Also, additional dilution may be necessary to achieve the uniform, overlapping fan-shaped spray desired from the nozzles.

Breaking of Tack Coat

Tack coat must “break” (cure) before it is covered with hot mix asphalt, to ensure bonding between pavement layers. As water evaporates from the asphalt emulsion, the tack coat becomes “tacky” and changes from a brown color to black. The rate of evaporation will vary depending on the type and grade of emulsion used, the application rate, the temperature of the existing pavement surface, and other environmental conditions. The pavement surface must be completely



clean and free of moisture before the tack coat is applied. Tack coats shall not be applied when the temperature on the base being covered is less than 25 degrees F.

Flushing or Bleeding

Flushing or bleeding is the upward movement of asphalt binder in the hot mix asphalt pavement resulting in the formation of a film of asphalt binder on the surface. The most common cause is too much asphalt binder in one or more of the pavement courses, resulting from too rich a plant mix, an improperly constructed seal coat, too heavy a tack coat, or solvent (such as diesel fuel) carrying asphalt binder to the surface. It may also occur when a new mat is released to traffic before it has sufficiently cooled, or by over-compacting during rolling operations. Some possible solutions to these situations include reducing the asphalt binder content, checking the plant calibration, reducing the tack rate, prohibiting the use of solvents, allowing the mat to cool longer before opening to traffic, and finally, establishing and maintaining a consistent rolling pattern.



Tender Mixes

High Temperature Tenderness

Some HMA mixes exhibit tenderness (low mix viscosity) at high temperatures, typically seen as pushing and shoving under the initial breakdown rollers. Likely causes for high temperature tenderness include excess sand or excess asphalt binder in the mix.



An incorrect binder grade can also contribute to the tenderness problem.

A simple solution to this problem is to delay initial breakdown rolling, allowing the mix viscosity to increase to the point of supporting the rollers. The danger in delaying rolling is failure to obtain required density, due to the cooler mat temperatures. Binder and aggregate changes may also be needed to overcome mix tenderness occurring at or near placement temperatures.

Mid-Range Tenderness

On some Superpave designed mixtures, a tender zone has been identified in temperature ranges of approximately 200-240 degrees F. The mixture can be satisfactorily compacted above this range or below this range, but the mixture tends to push and shove under steel-wheeled rollers within the temperature range. Rolling with a steel roller within the tender zone may actually cause decompaction and will likely damage the mat. If used carefully, a pneumatic roller may be utilized to compact within this tender range but may have mix pick-up problems when modified asphalt binders are used. Pneumatic rollers can also introduce tire marks in the mat that may be difficult to remove later with the finish roller.

When a mixture is being produced that is found to be tender, the preferred compaction method is to obtain density prior to cooling into the tender zone. It is important to get the breakdown roller(s) close behind the paving machine in order to obtain as much compaction as possible before the mat cools into the tender zone temperature range.



Chapter 9

This may require additional rollers or, in some cases, the mixture temperature may be increased slightly to provide more compaction time. Once the mat has cooled below the tender zone, a steel-wheeled roller may be used to finish compaction and remove marks.

Mix Pickup

Mix pickup, particularly by pneumatic (rubber-tired) rollers, has always been a concern when compacting HMA mixes. The problem has been magnified in recent years with the increasing use of polymer-modified binders. Polymer-modified binders tend to be more “sticky” than conventional binders, requiring additional diligence on the part of the contractor during compaction operations.

When the binder sticks to the roller, fines are pulled from the surface of the mat. This creates an open texture on the mat surface, which in extreme cases can lead to similar consequences as mix segregation. The fines accumulate on the tires until they slough off, forming “patties” on the surface of the pavement. Though very undesirable from roughness and cosmetic standpoints, the patties themselves are not usually detrimental to pavement performance. If possible, remove the loose patties from the pavement surface before performing additional rolling.

The best technique to minimize mix pickup is to keep roller tires hot, as close to mix temperature as possible. The roller tires (and drums) should be kept clean, to prevent mix from accumulating.



Chapter 9

To do so, the roller's spray bars, mats, and scrapers should be in place and properly functioning. Use of approved release agents in the roller's water system may also help prevent mix from sticking to tires and drums.

Roller Marks

There are a variety of causes for roller marks in a finished HMA surface. Mix tenderness, mentioned previously, may result in roller tire indentations that are unable to be removed by subsequent rolling. Excessive tire pressures or roller weights, along with improper rolling techniques, can also contribute to the problem.

As mentioned previously in this chapter, rolling a very tender mix should be avoided if possible. Contractors should properly maintain their equipment (tire pressures, ballast, etc.) and operate rollers at appropriate speeds, avoiding abrupt turns and stopping on hot mat, while maintaining consistent rolling patterns. Workmanship and attention to details are keys to a good looking mat.

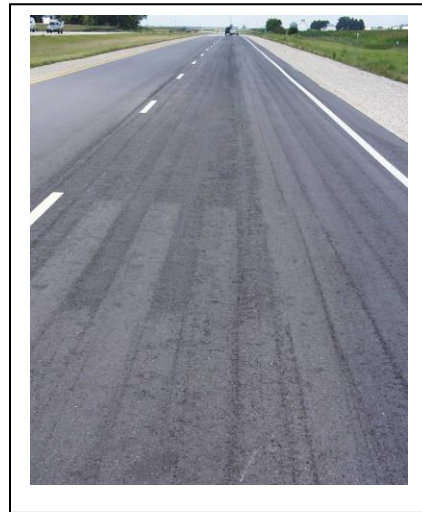

Wavy Surface

There are a wide variety of sources that may cause the pavement to have a wavy surface. It all starts with the mix coming from the plant. Temperature fluctuations in the mat are a problem and can lead to waves due to non-uniform compaction. Also, excessive speed or incorrect impact frequency of a vibratory roller may result in corrugations or “washboarding” effect on the pavement surface.

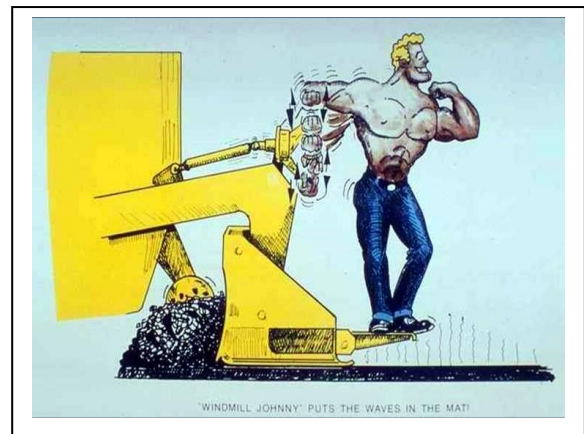

Another possible cause is drivers improperly setting or holding the brakes on delivery trucks. This impedes the forward motion of the paver, thereby reducing paving speed and increasing mat depth in localized areas. The paver itself can create waves as well. In addition to paver speed, fluctuating hopper level and the paver's feeder screws and grade control devices can all contribute to making waves. Work with the Contractor to determine the cause and the adjustments or changes in operation necessary to eliminate the problem.



Reflective Bumps

Reflective bumps typically occur on the first lift of HMA resurfacing over filled pavement joints. This results in a lack of smoothness and may lead to cracking and further deterioration of the pavement. It is believed that the heat from the overlay draws the joint filler / sealant to the surface, where it creates a bubble under the HMA lift. Steel rollers often accentuate the bump as they roll across the joint location.

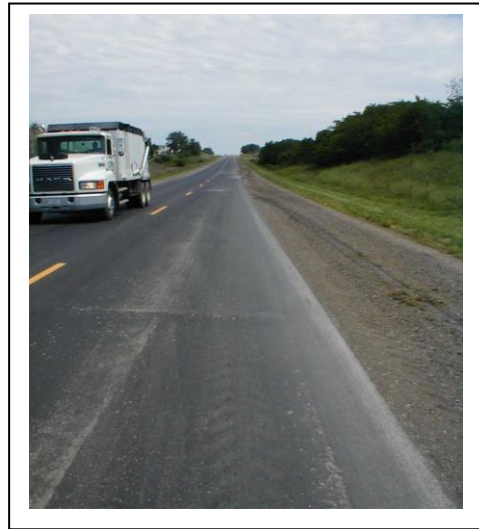

To minimize the potential for reflective bumps, it is important that all loose or excess joint material be removed prior to overlay. It is also recommended to keep Maintenance forces aware of upcoming resurfacing projects so that crack filling or joint sealing is not done in the months just prior to the resurfacing.

During construction, make sure to use the proper tack coat application rate and consistency. If reflective bumps are encountered, breakdown with a pneumatic roller and/or delaying or

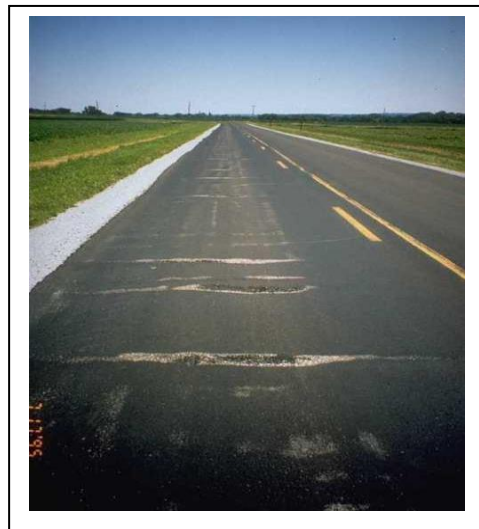

eliminating the steel finish roller may help minimize the effect. If the project involves multiple lifts of resurfacing, good results have been obtained by “tight blading” (shaving off) the bumps prior to placing upper HMA lifts.

Cracking

There are several different types of cracking that can occur in a HMA pavement surface. Cracking may occur immediately in a newly placed mat or may show up at a later time. Over-rolling can be a prime cause of cracking in a newly placed mat. Watch for over-rolling, particularly at transverse headers or when the contractor is trying to roll out a bump. Following are discussions of some of the more common types of cracking in HMA pavements, which may occur at time of construction (checking) or at some point later in the life of the pavement (low temperature or fatigue).

Checking

Checking is defined as short transverse cracks that typically do not extend completely through the course but are approximately ½ inch in depth. Checking is primarily due to mix deficiencies resulting in a tender mix but may also be caused by excessive deflection in pavement structure under the compaction equipment. To a lesser extent, overheated mix can contribute to checking as well. The long-term solution is to change mix properties. In the short-term, the amount of checking can be reduced by changing the rolling zone and type of rollers used to compact the mix.



Chapter 9

Low temperature, fatigue, and reflection cracking are other types of cracking that may develop later in the life of hot mix asphalt pavements.

Low Temperature (Thermal) Cracking

Low temperature cracking is largely an environmental distress, due to stresses and strains induced by temperature change. This distress shows up as transverse cracks in full depth pavement, spaced from 20 to 100 feet apart. Low temperature cracking is not traffic or aggregate related; the asphalt binder in the mix largely influences it.

Low temperature cracking may be prevented or minimized by:

- Using a less stiff (softer) asphalt binder.
- Using an asphalt binder less prone to aging (based on experience & testing results).
- Constructing hot mix asphalt with proper air voids.

Fatigue Cracking

Fatigue cracking first exhibits itself as distress in wheel paths. It results in progressive damage, such as longitudinal cracking, alligator cracking, or potholes. Fatigue cracking is affected by a number of factors, including asphalt binder, aggregates, pavement structure, or failure of the subgrade.

Fatigue cracking may be prevented or minimized by:

- Designing for actual number of heavy loads.
- Keeping subgrade dry (low deflections).
- Using thicker pavements.
- Using resilient paving materials.

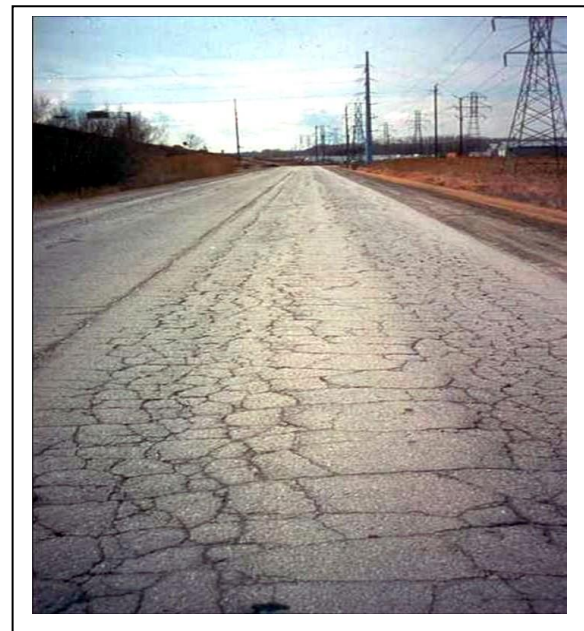

Chapter 9

- Using materials that are not moisture sensitive.

Reflection Cracking

Reflection cracking occurs in HMA overlays over cracked or jointed pavements. The cracks in the overlays reflect the crack pattern in the pavement structure underneath. They are caused by vertical or horizontal movements in the pavement beneath the overlay and brought on by expansion and contraction with temperature or moisture change.

While little can be done to completely prevent this problem, there are treatments available that have varying degrees of success in delaying the onset of reflection cracking. Most of these treatments involve placement of fabric, membrane, or another elastic interlayer between the existing pavement and the HMA overlay.



Rutting

Pavement rutting is a permanent deformation, typically seen in the vehicle wheel paths. Rutting usually occurs during periods of high temperature extremes, combined with heavy vehicle axle loads on the affected pavement. Rutting may occur in the subgrade or subbase, due to a weak subgrade or underlying layer, or in the hot mix asphalt itself. If properly designed and constructed, gyratory (Superpave) mixes should not experience rutting.

Rutting may be prevented or minimized by:

- Specifying the appropriate asphalt binder grade.

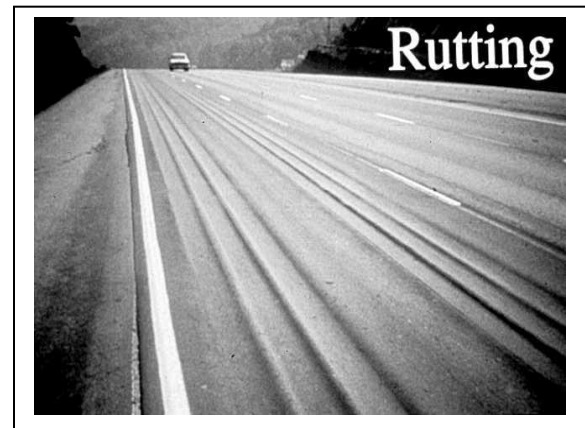

Chapter 9

- Not using too much asphalt binder (stay below the maximum film thickness).
- Using cubical, crushed aggregate.
- Providing good aggregate gradation (skeleton).
- Achieving proper compaction.

Crushing Aggregate

Aggregate crushing may be seen as white spots on the surface after rolling. This is often a result of rolling a cold mat or using a vibratory breakdown roller that is too heavy or operating at excessive amplitude. Softer aggregates are obviously more prone to crushing than harder, more durable material. Aggregate crushing was more common on projects using early coarse Superpave mixes, which typically had more stone-on-stone contact than more recent mixes.

Current mix requirements have reduced the problem to some extent, by providing more room within the mix for aggregate to be reoriented during the compaction process. As a rule of thumb, the compacted lift thickness should be 3 to 4 times the nominal maximum aggregate size in the mix.

The breakdown rolling needs to take place at a high enough mat temperature so that the asphalt binder's viscosity remains low enough to lubricate (rather than bind) the aggregate. During compaction, this helps the particles slide past each other and reorient themselves into a more dense configuration.



In addition, vibratory breakdown rollers should use low amplitude and high frequency settings to “massage” (rather than “hammer”) the mix into place.

Longitudinal (Centerline) Joints

Pavements with high quality longitudinal (centerline) joints will last longer and require less maintenance than those with poorly constructed joints. As discussed in a previous chapter, there are certain procedures to follow in order to obtain a tight, well-matched centerline joint. These concepts are worthy of repeating here.



First Lane Placement

- Use a string line to maintain true edge alignment at longitudinal joint locations. The string line should be secured with extra nails in curves to minimize the “chord” effect, thereby facilitating a better joint match by the second lane.
- Provide enough mix at the end of the screed by maintaining a consistent head of mix along the length of the paver augers. Mix confinement by end gate will result in uniform edge to match.
- The vertical face of the exposed longitudinal joint (cold mat) must be tack coated as a separate operation before placing the adjacent lane. This insures a good seal at the joint. Do not allow tack to be sprayed on the surface of the lane being matched.



Second Lane Placement

- Allow 1/2 to 1-1/2 inches of overlap at the joint, with 1-inch being preferred. Too much lap at

centerline will result in a wide scab of mixture at the surface or the appearance of a white streak at the joint, caused by the roller crushing aggregate in the mix against the surface of the cold mat.

- Allow enough loose lift thickness to compensate for roll down so that no bump or dip is produced at the joint (20 to 25 percent reduction in thickness is typical). If loose lift thickness is insufficient prior to rolling, the joint will appear smooth but lack density.
- Keep the end plate of the paver tight against the screed and tight against the surface of the cold mat. Do not allow mix to run out between the edge of screed and end plate, or in front of the end plate.
- Minimize the amount of handwork used in constructing longitudinal joints. This includes raking, luting, and “bumping” the joint. If excess mix is placed at the joint location, the extra material should be pulled back and removed, rather than “broadcast” across the mat’s surface. Once adjusted, the paver will do a better job of uniformly placing the mix than by using hand tools.
- Compact the joint from the hot side of the joint, not the cold side. This allows thru traffic to use the adjacent lane and also prevents damage to the cold mat by vibratory (breakdown) rollers. Never have the vibrators turned on when the breakdown roller is being supported mainly on the cold side of the joint.

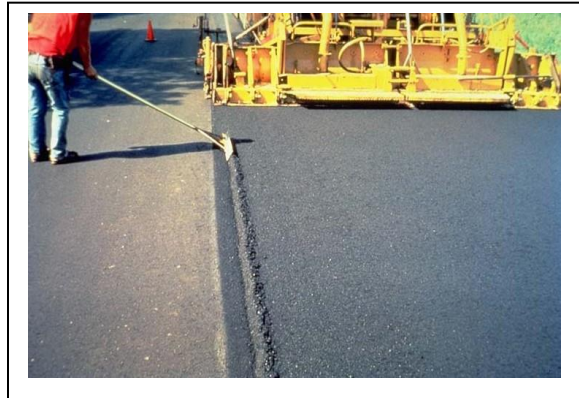

Chapter 9

Notched Wedge Longitudinal Joint

The Notched Wedge Joint has been used successfully to overcome density and resulting cracking and raveling problems often associated with conventional butt joint construction. This alternative has been shown to increase the in-place density at the longitudinal joint, resulting in a tighter, longer lasting joint.

As its name suggests, the configuration (cross-section) of the Notched Wedge Joint consists of “notch” and “wedge” portions.

Notch

- Located at the top of the lift.
- Defines the joint location.
- Provides a vertical edge for matching and compacting the second side against.
- Compacted notch depth is approximately $\frac{1}{4}$ " more than the nominal maximum aggregate (mix) size, but no more than half the intended lift thickness. Loose notch depth must account for roll-down of the mat during compaction.

Wedge

- Sloping portion of the joint, diagonally from the bottom of the notch.
- Slope of the wedge may vary, but is typically 12:1.
- Width of the wedge is typically 12", but may vary with the lift thickness.
- Vertical step at the toe of the wedge is acceptable (and usually preferred).

The Notched Wedge Joint (NWJ) is formed by an attachment to the end of the paver screed, which extrudes the shaped edge of the first side (lane)

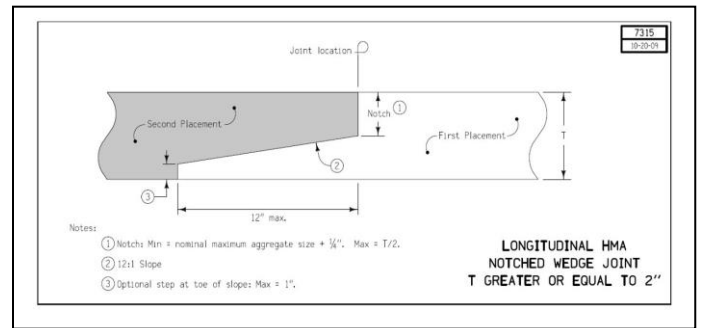

Chapter 9

placed. Adjustments can be made to vary the notch depth and wedge slope. A small trailing roller acts to “set” the wedge, while providing some compaction. Conventional methods are used for compaction of the mat itself, and for placing and compacting the second side of the joint (lane) to match.

Details of the NWJ may be included in the contract documents for the project. If the NWJ is not specified for the project and the contractor requests approval to use it, contact your supervisor and/or the Office of Construction to determine if its use is appropriate for the situation.



Screed Marks / Mat Texture

There are a number of different issues that may contribute to the appearance of screed marks and variations in mat texture behind the paver. Some of these mat defects may be purely cosmetic in nature, while others could result in poor pavement characteristics or performance.



Screed Settling

Screed settling usually occurs when the paver is stopped for lengthy periods of time. Delays may be caused by paver or plant-related breakdowns, or due to a lack of timely arrivals of mix delivery trucks. Another source of screed settling occurs whenever a delivery truck backs into and bumps the paver, causing the screed to drop. The resulting dip in the mat may be difficult to remove, sometimes becoming even more pronounced by the efforts to roll it out.



Chapter 9

Cold Screed

A paver's screed should be heated before paving proceeds. Generally, the screed heaters may then be turned off after paving is underway, as the mix then keeps the screed hot. If the screed is too cold, mix will not readily flow under the screed, with larger aggregate catching and dragging under the screed plate. The resulting pavement surface appears coarse and open-textured, similar to a segregated mix.



Screed Crown

If there is an open or torn texture at the center of the mat behind the paver, additional lead crown may be needed in the front edge of the screed. This forces more mix into the central portion of the screed, closing the texture. If the tears occur on the outer edge, there may be too much crown in the leading edge, forcing too much material in the center and too little at the edges. Reducing the center crown slightly will distribute more material toward the edges and provide a more uniform mat.

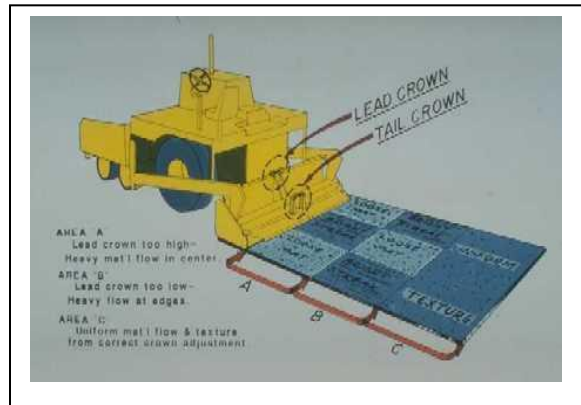

Mat Problem Trouble-Shooting

Many potential problems and possible solutions regarding hot mix asphalt paving are included in the Mat Problem Trouble-Shooting Guide, found in the Appendix (Chapter 10).

Problem	CAUSES									
	1. Poor Mix Compaction	2. Poor Precompaction	3. Poor Longitudinal Joint	4. Poor Transverse Joint	5. Screed Not Responding to Correction	6. Screed Marks	7. Mat Showing Under Roller	8. Roller Marks	9. Poor Mix Compaction	10. Poor Precompaction
Wavy Surface - Short Waves (Ripples)	✓	✓	✓	✓	✓	✓	✓	✓	✓	✓
Wavy Surface - Long Waves	✓	✓	✓	✓	✓	✓	✓	✓	✓	✓
Tearing of Mat - Full Width	✓	✓	✓	✓	✓	✓	✓	✓	✓	✓
Tearing of Mat - Center Streak	✓	✓	✓	✓	✓	✓	✓	✓	✓	✓
Tearing of Mat - Outside Streaks	✓	✓	✓	✓	✓	✓	✓	✓	✓	✓
Mat Texture - Nonuniform	✓	✓	✓	✓	✓	✓	✓	✓	✓	✓
Screed Marks	✓	✓	✓	✓	✓	✓	✓	✓	✓	✓
Screed Not Responding to Correction	✓	✓	✓	✓	✓	✓	✓	✓	✓	✓
Auger Shadows	✓	✓	✓	✓	✓	✓	✓	✓	✓	✓
Poor Precompaction	✓	✓	✓	✓	✓	✓	✓	✓	✓	✓
Poor Longitudinal Joint	✓	✓	✓	✓	✓	✓	✓	✓	✓	✓
Poor Transverse Joint	✓	✓	✓	✓	✓	✓	✓	✓	✓	✓
Transverse Cracking (Checking)	✓	✓	✓	✓	✓	✓	✓	✓	✓	✓
Mat Showing Under Roller	✓	✓	✓	✓	✓	✓	✓	✓	✓	✓
Roller Marks	✓	✓	✓	✓	✓	✓	✓	✓	✓	✓
Poor Mix Compaction	✓	✓	✓	✓	✓	✓	✓	✓	✓	✓

Procedure for Using Table
 1. Find problem above.
 2. Checks indicate causes related to the paver.
 3. X's indicate other problems to be investigated.

NOTE: Many times a problem can be caused by more than one item. Therefore, it is important that each cause listed be eliminated to assure solving the problem.