

① Slope 10:1 or flatter without pipe, 8:1 or flatter with pipe.

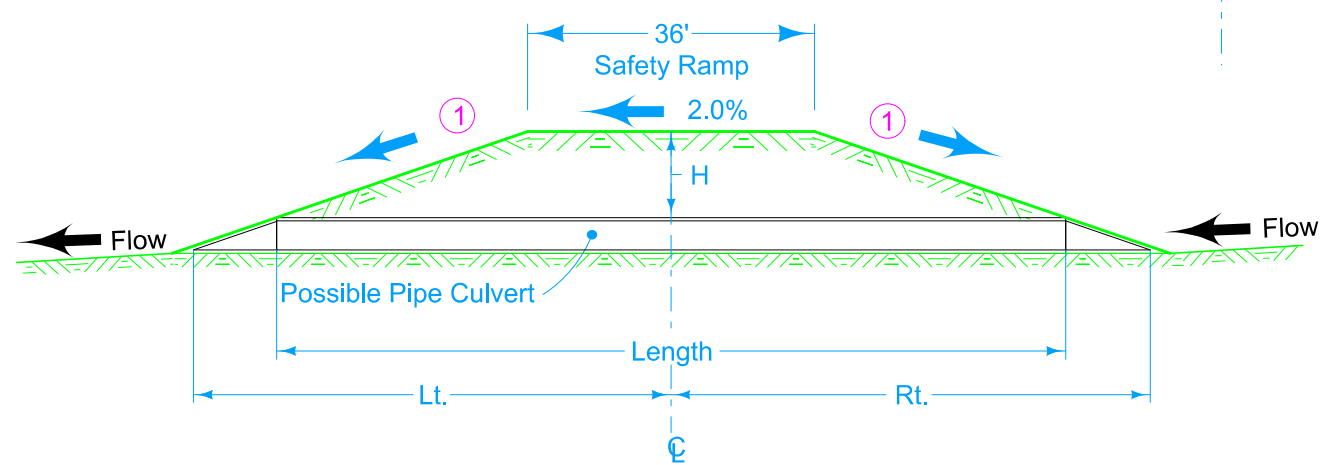
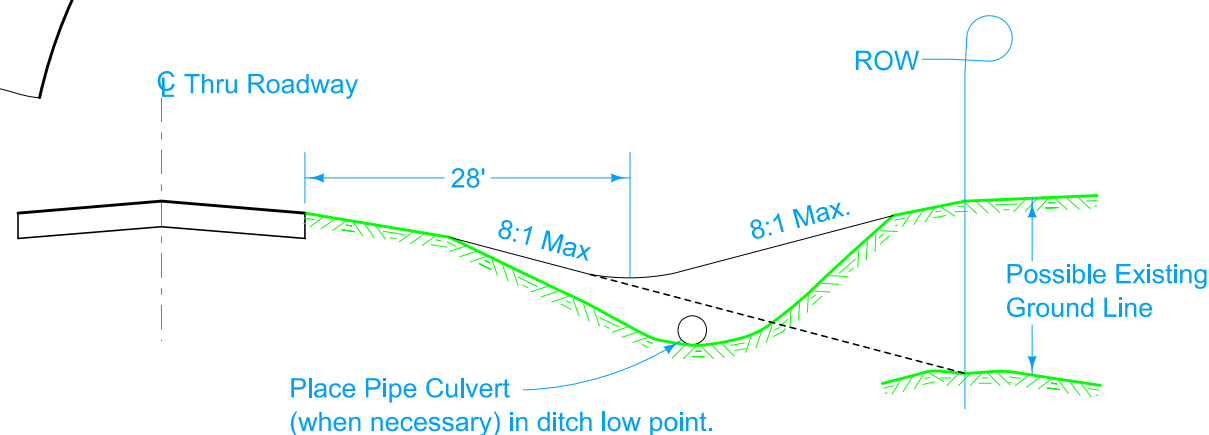

Possible Contract Items:
 Aprons, Unclassified Culvert, Unclassified Entrance Pipe Excavation, Class 10

Possible Tabulation:
 102-3

	REVISION	
	2	04-18-17
STANDARD ROAD PLAN		EW-502
REVISIONS: Added Designer Info button.		SHEET 1 of 1
APPROVED BY DESIGN METHODS ENGINEER		

SAFETY RAMP