

Extend thrust blocks to undisturbed soil. Excavation into trench wall may be necessary.

Form vertical surfaces of poured concrete thrust blocks except on bearing surface.

Encase all fittings in polyethylene wrap. Do not allow concrete to directly contact joints or fitting bolts.

Diameter of Pipe, D (inches)	MINIMUM BEARING SURFACE (sf)				
	Bends				Tees and Dead Ends
	11 $\frac{1}{4}$ ^o	22 $\frac{1}{2}$ ^o	45 ^o	90 ^o	
4	1	1	2	4	3
6	1	2	4	8	6
8	2	4	7	14	10
10	3	6	11	21	15
12	4	8	16	29	21
14	5	11	21	39	28
16	7	14	27	50	36
18	9	17	34	63	45
20	11	21	42	78	55
24	15	31	60	111	78
30	24	47	92	171	120
36	34	67	132	244	173

Minimum surface area based on water pressure of 150 psf and allowable soil pressure of 1,000 psf.

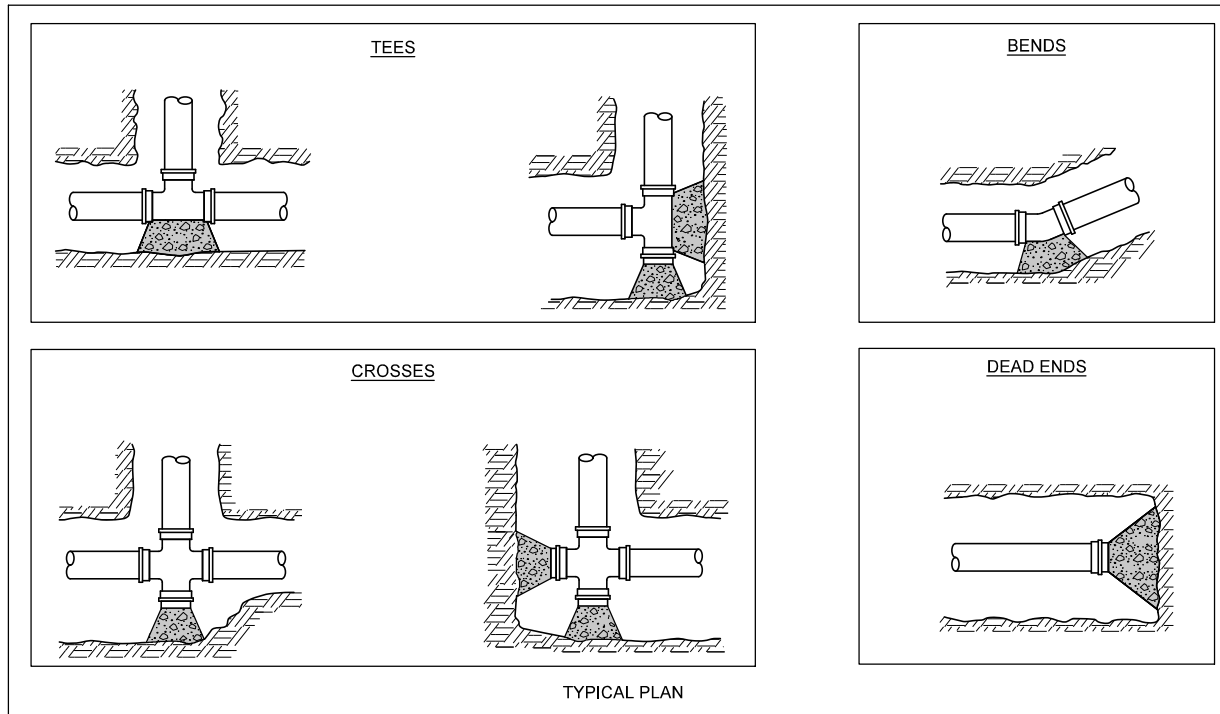

		REVISION
		1 10-18-16
FIGURE 5010.101	STANDARD ROAD PLAN	WM-101
		SHEET 1 of 2
<small>REVISIONS: Replaced Iowa DOT and SUDAS logos with new logos.</small>		
 SUDAS DIRECTOR		 DESIGN METHODS ENGINEER
THRUST BLOCKS		

CHANGES IN PIPE DEPTH

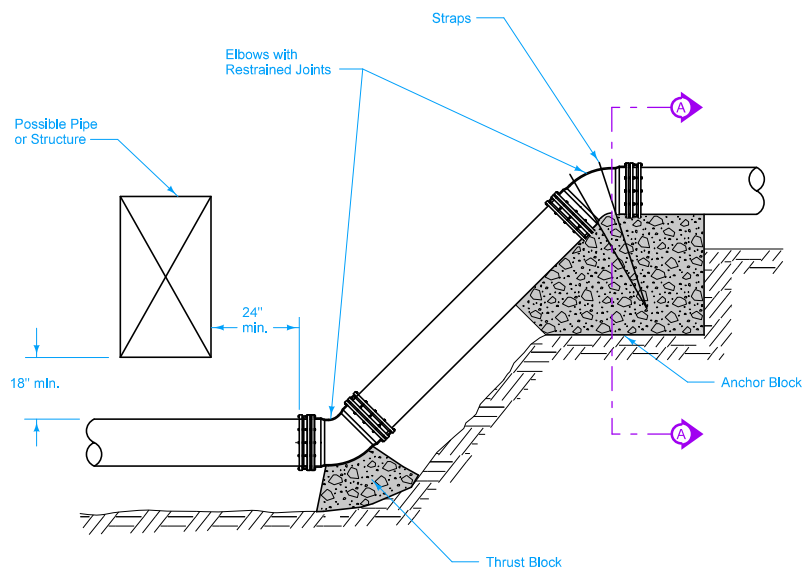

ELEVATION

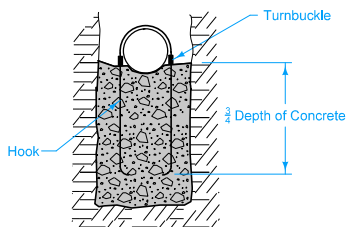

SECTION A-A

DEAD ENDS (ALTERNATE METHOD)

Use only when allowed by the Engineer, or when specified in the contract documents.

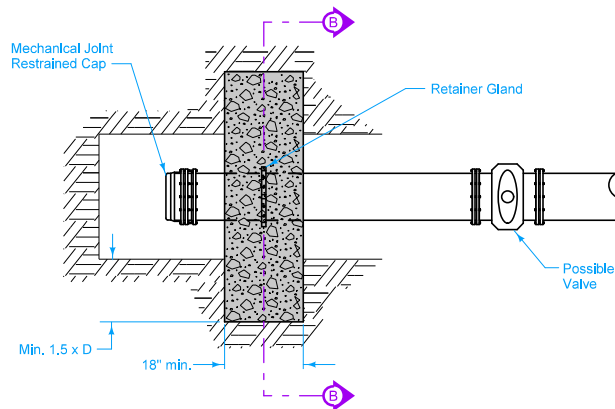

PLAN

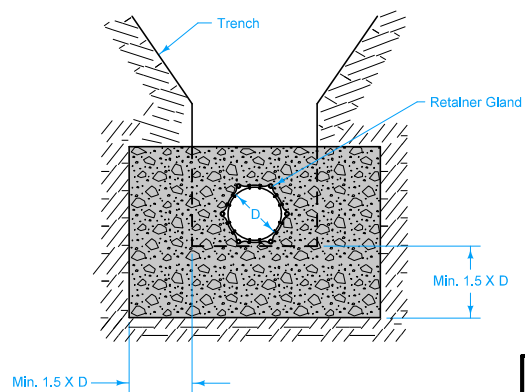

SECTION B-B

FIGURE 5010.101 SHEET 2 OF 2

		REVISION
		1 10-18-16
FIGURE 5010.101	STANDARD ROAD PLAN	WM-101
		SHEET 2 of 2

REVISIONS: Replaced Iowa DOT and SUDAS logos with new logos.

Paul D. Wigand SUDAS DIRECTOR *Brian Smith* DESIGN METHODS ENGINEER

THRUST BLOCKS