

R_1 = Radius of foundation. Minimum $13\frac{1}{2}$ " and minimum of 2" greater than R_2 .

R_2 = Radius of the reinforcing tie. Minimum of 1" greater than R_3 .

R_3 = Radius of the anchor bolt circle.

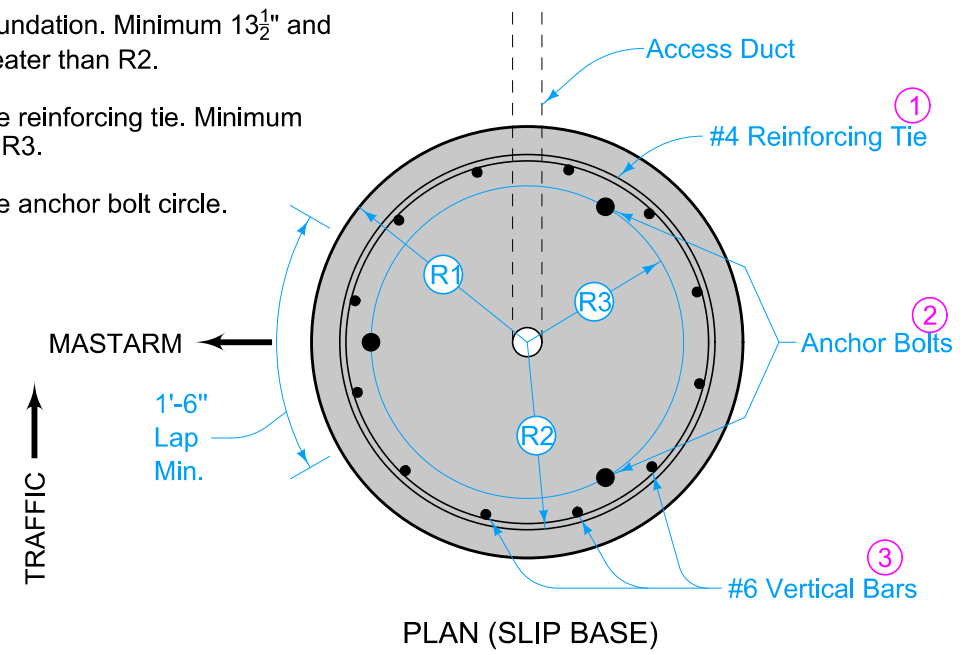

The Type A Foundation is the normally required foundation construction. Where rock, shale, sandstone, broken or shattered rock, or other similar material is encountered, the Engineer may approve the use of the Type B or C Foundation. Dispose of all excavations in the area adjacent to the foundation and shape to the natural contour unless directed otherwise by the Engineer.

Minimum diameter of foundation is determined by the Anchor Bolt Circle required for the diameter of the pole being installed. Where dimensional requirements indicated cannot be met with normal foundations, enlarge the foundation as necessary to accommodate the required diameter at no additional cost to the Contracting Authority.

Provide minimum 2" clear for all reinforcement.

Cap open ends of conduit during construction to prevent infiltration of foreign material. After the cable is installed, seal the upper end of the ducts against entry of moisture by a method approved by the Engineer.

For access ducts, use a 2" nominal inside diameter duct.

For Transformer Base foundations, install a minimum of two access ducts, unless specified otherwise. Also install a 1" nominal inside diameter duct for the ground wire duct.

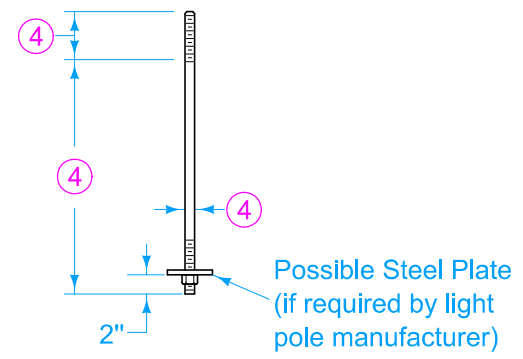
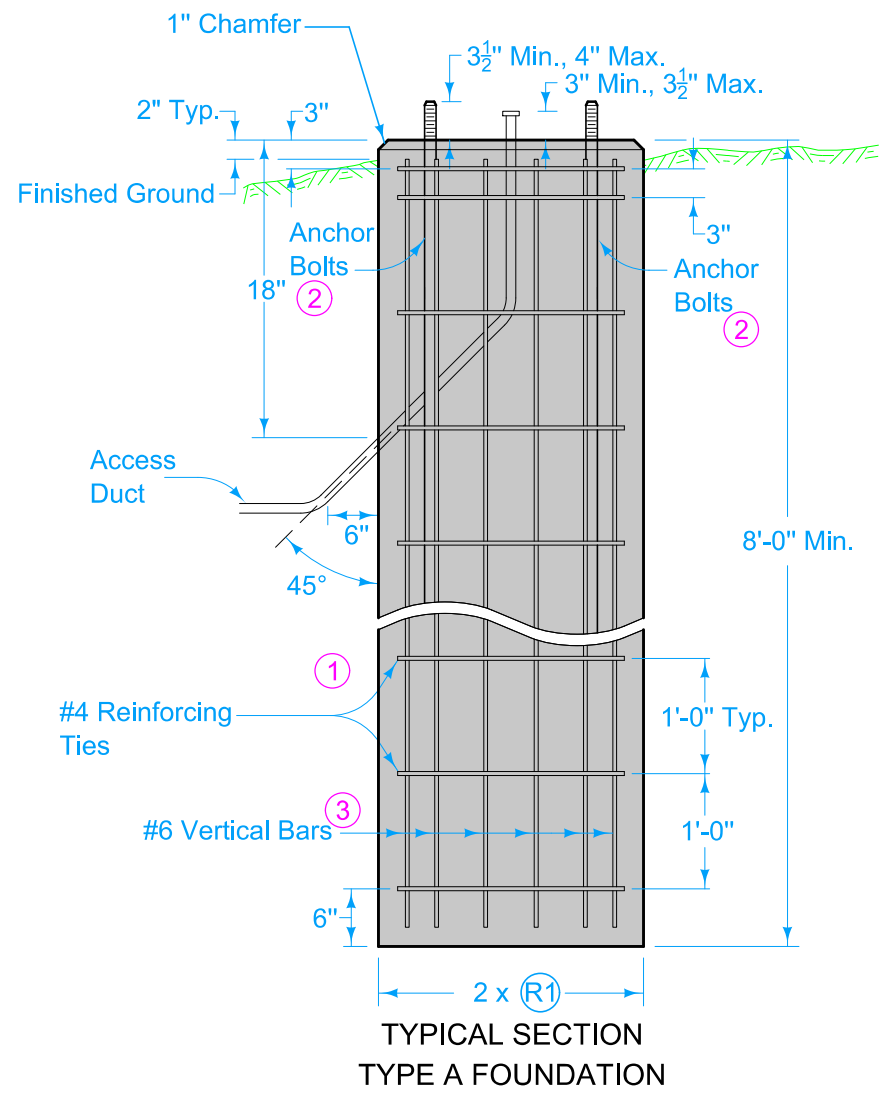

ANCHOR BOLT

- ① #4 bars lapped a minimum of 1'-6" as indicated. Ties may be welded to vertical bars.
- ② Use full length galvanized anchor bolts: four for Transformer Base, three for Slip Base. Refer to the light pole manufacturer's requirements for anchor bolt, nut, and plate dimensions. Obtain a template from the light pole manufacturer for anchor bolt placement. Do not weld anchor bolts.
- ③ Place 12 equally spaced bars. Use #6 bars for 27 inch diameter drilled shaft. Use #7 bars for 30 inch diameter drilled shaft. Use #8 bars for 36 inch diameter drilled shaft.
- ④ Refer to light pole manufacturer's recommendations for Anchor Bolt dimensions.

 STANDARD ROAD PLAN	REVISION
	2 04-18-17
LI-201	
SHEET 1 of 2	

REVISIONS: Revised number and size of vertical bars. Eliminated hooked anchor bolts. Added new Type C foundation.

Shawn Miller
APPROVED BY DESIGN METHODS ENGINEER

LIGHT POLE FOUNDATION

If the excavation for a Type B Foundation is left open for more than 1 calendar day, install temporary barrier rail if any part of the excavation is located within the clear zone. Temporary barrier rail layout requires the Engineer's approval. Temporary barrier rail is incidental to the Type B Foundation and will not be paid for separately.

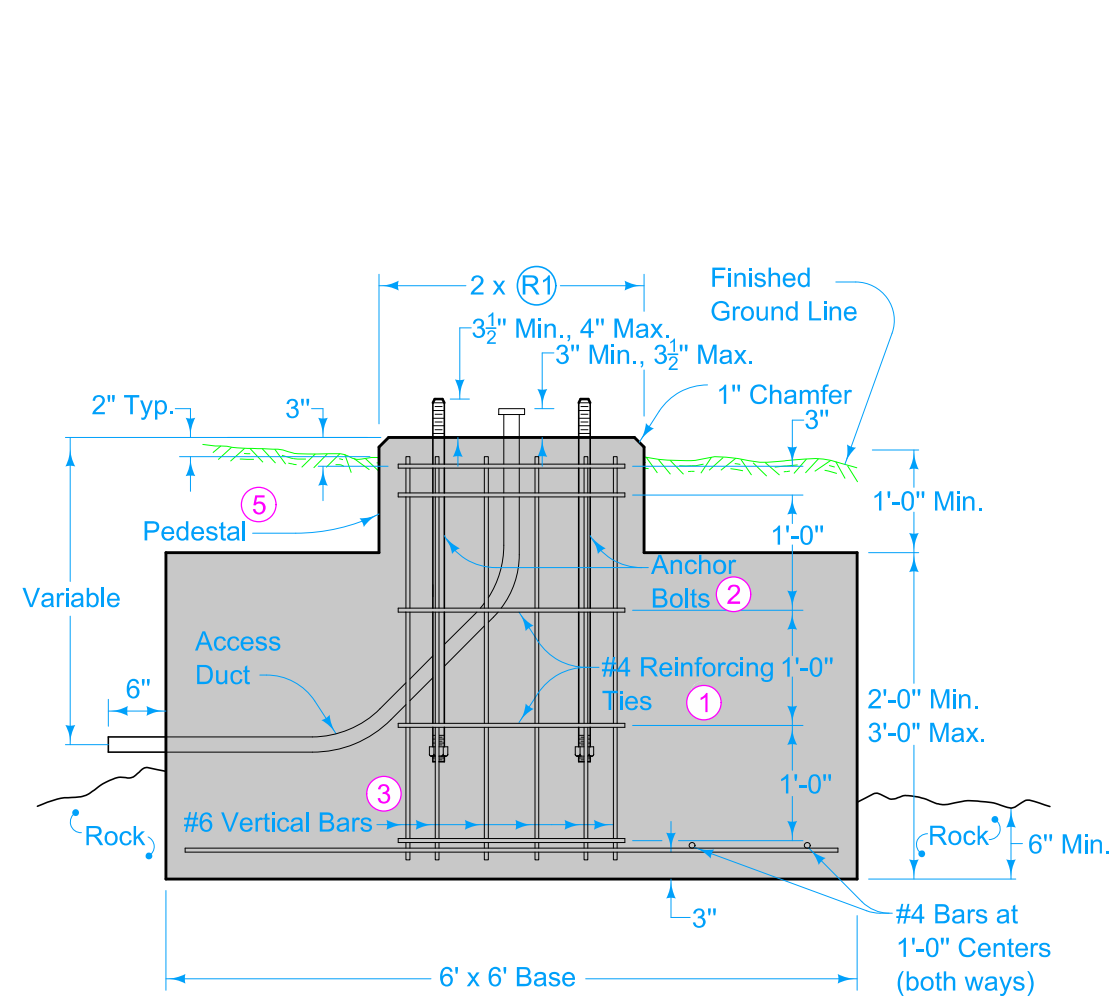

TYPICAL SECTION
TYPE B FOUNDATION

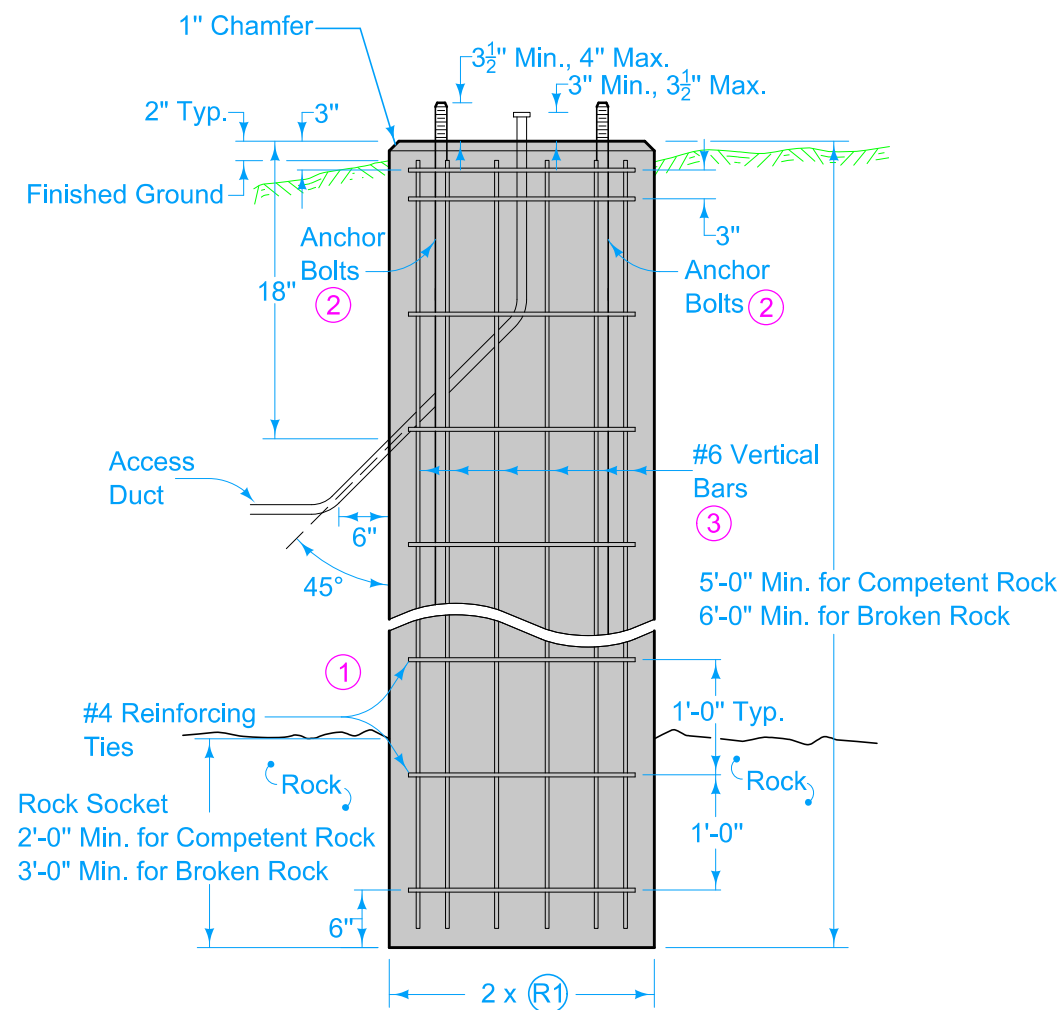

TYPICAL SECTION
TYPE C FOUNDATION

- ① #4 bars lapped a minimum of 1'-6" as indicated. Ties may be welded to vertical bars.
- ② Use full length galvanized anchor bolts: four for Transformer Base, three for Slip Base. Refer to the light pole manufacturer's requirements for anchor bolt, nut, and plate dimensions. Obtain a template from the light pole manufacturer for anchor bolt placement. Do not weld anchor bolts.
- ③ Place 12 equally spaced bars. Use #6 bars for 27 inch diameter drilled shaft. Use #7 bars for 30 inch diameter drilled shaft. Use #8 bars for 36 inch diameter drilled shaft.
- ⑤ Foundation base may be thickened and pedestal omitted at the contractor's option.

 STANDARD ROAD PLAN	REVISION	
	2	04-18-17
	LI-201	
SHEET 2 of 2		
REVISIONS: Revised number and size of vertical bars. Eliminated hooked anchor bolts. Added new Type C foundation.		
 APPROVED BY DESIGN METHODS ENGINEER		
LIGHT POLE FOUNDATION		