

Lane layouts shown are typical.

Centerlines and lane lines may be painted either side of centerline.

Drawings on sheets 1, 2 and 3 are oriented to represent direction of traffic moving from left to right.

6 inch lines intended for primary system roads, and 4 inch lines intended for secondary system roads.

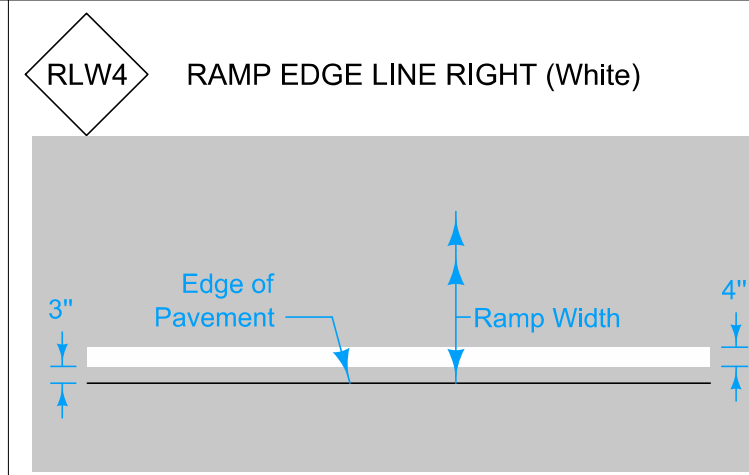
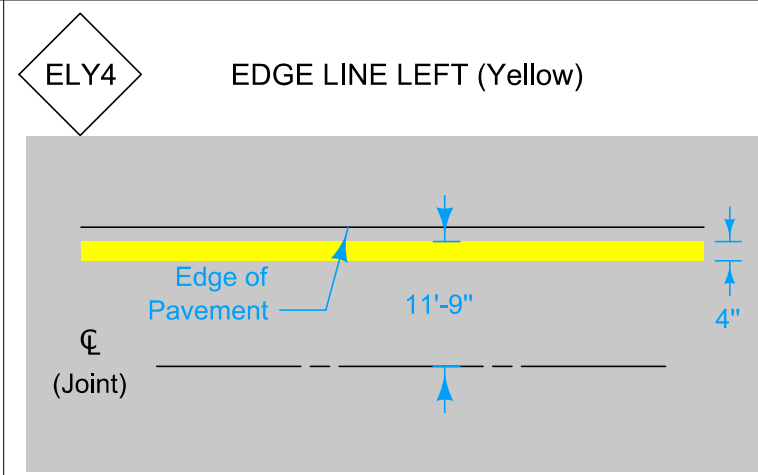
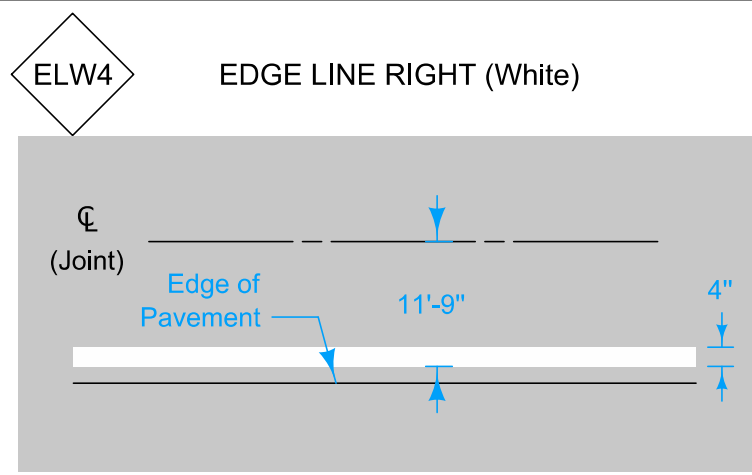
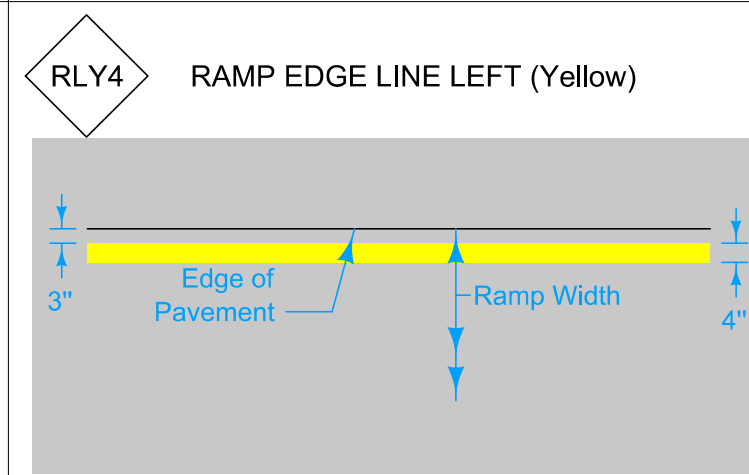
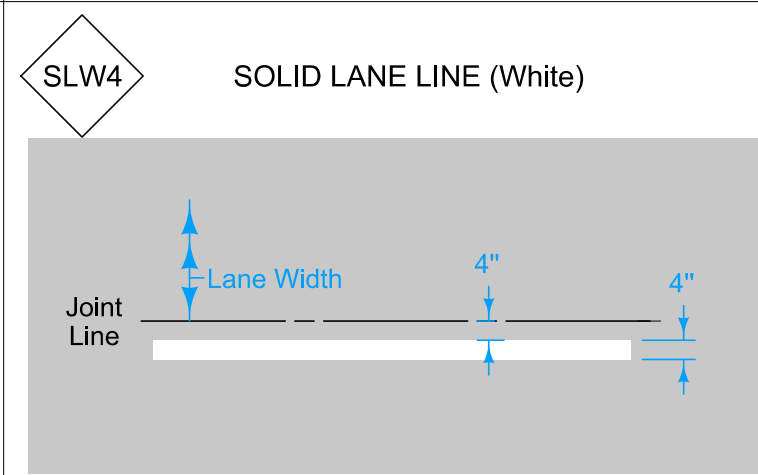
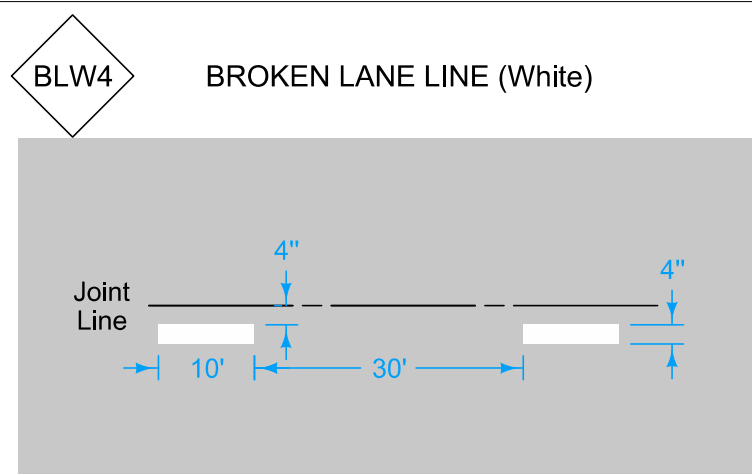

Possible Contract Item:
Pavement Marking Line Items

Possible Tabulation:
108-22

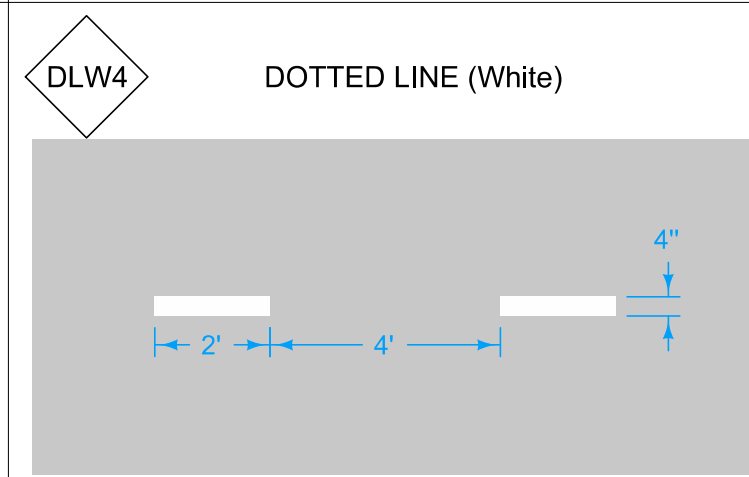
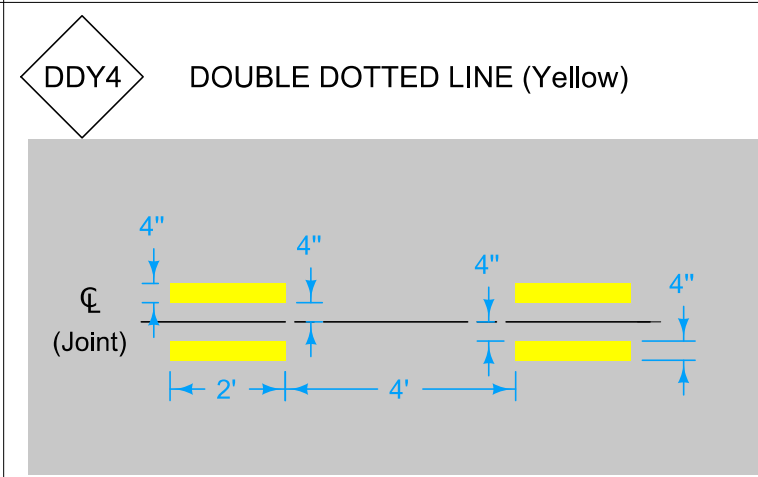
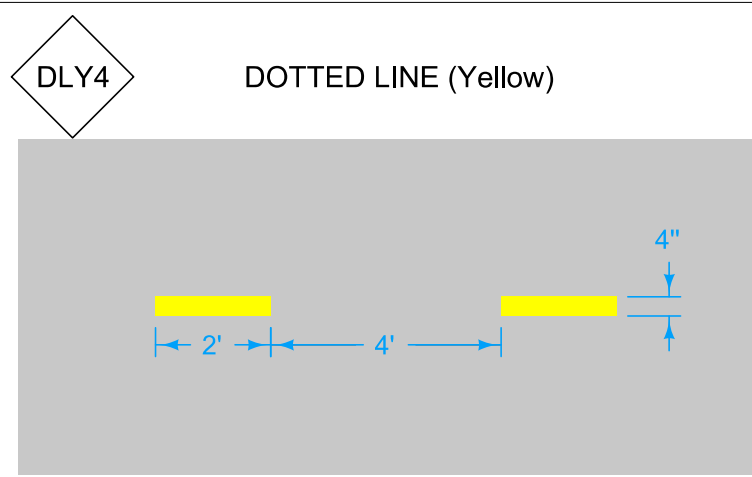

	REVISION
	5 10-15-24
	PM-110
STANDARD ROAD PLAN	
SHEET 1 of 4	
REVISIONS: Added note about primary and secondary roads.	
 APPROVED BY DESIGN METHODS ENGINEER	
LINE TYPES	

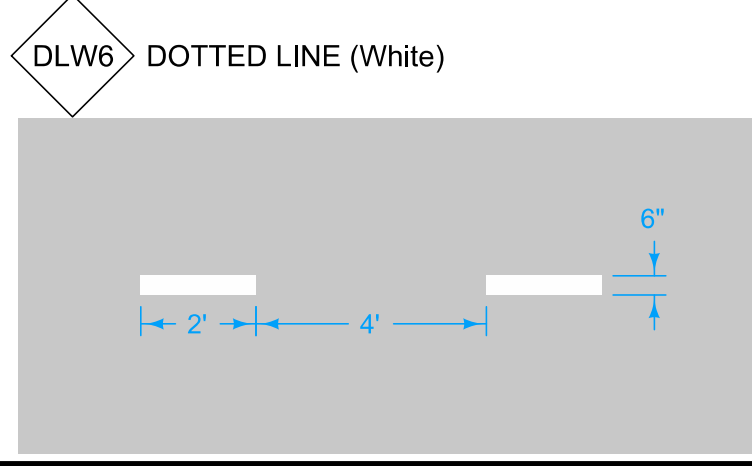
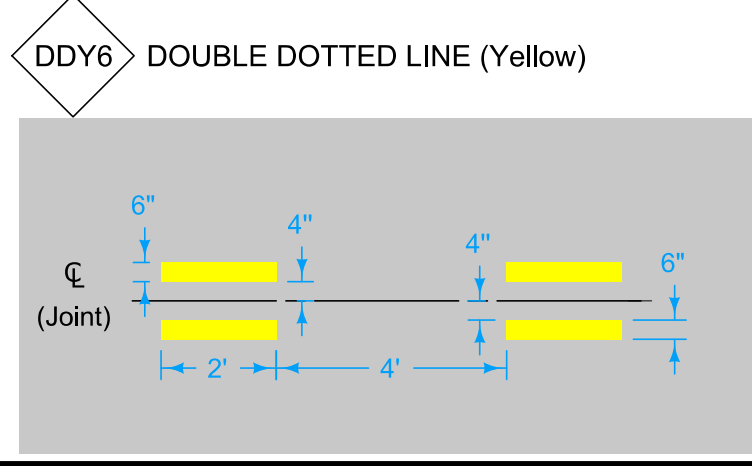
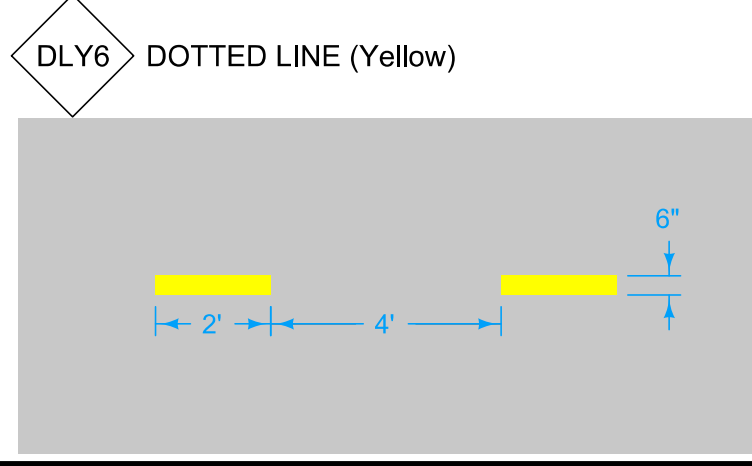
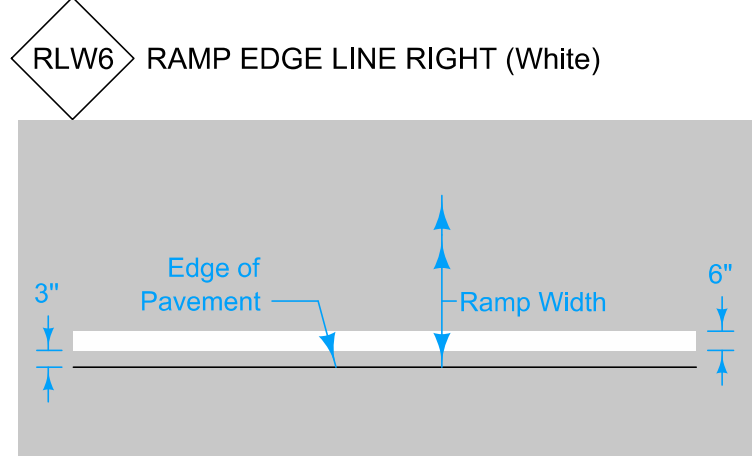
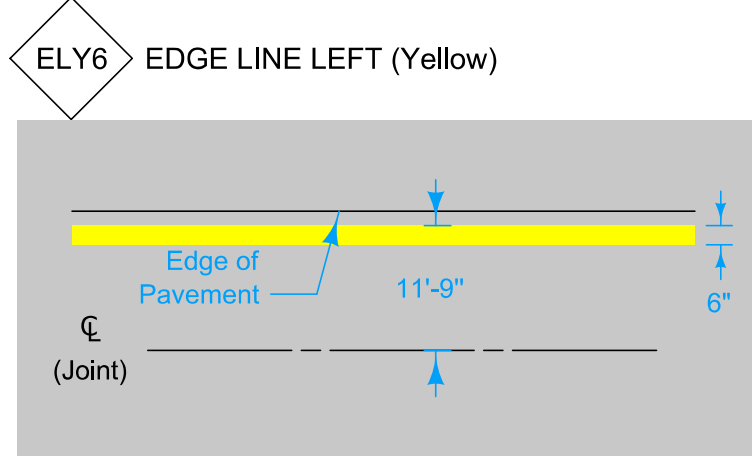
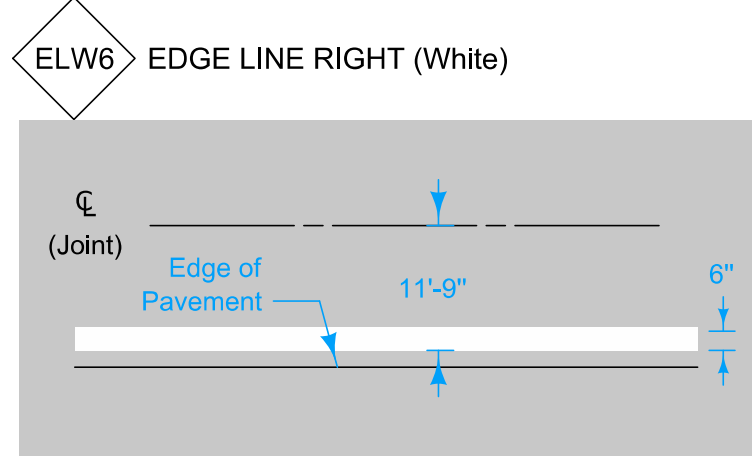
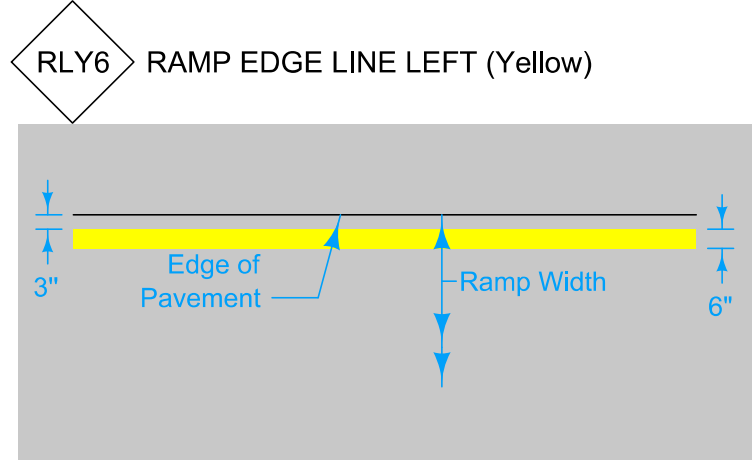
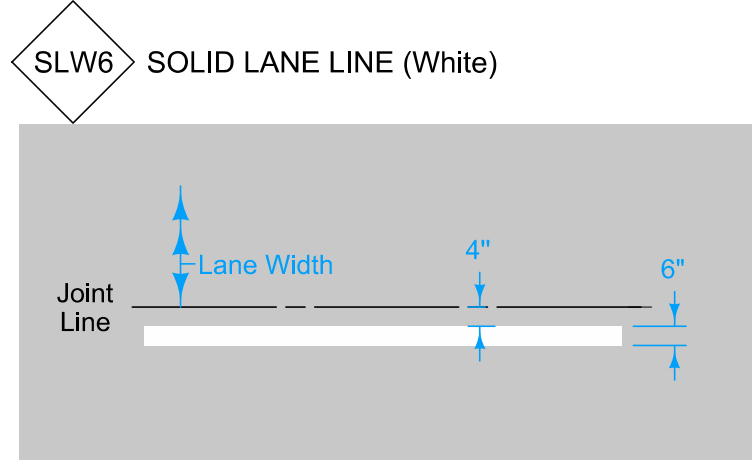
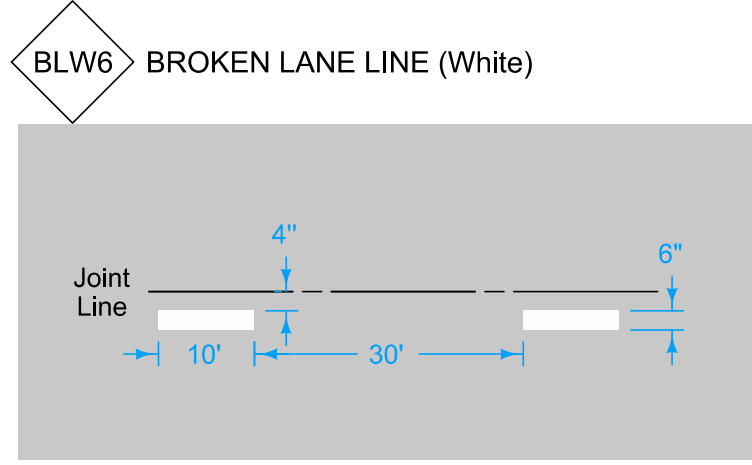
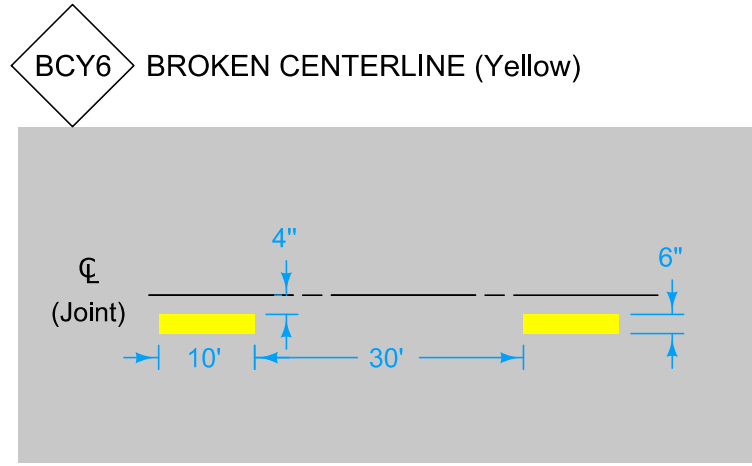
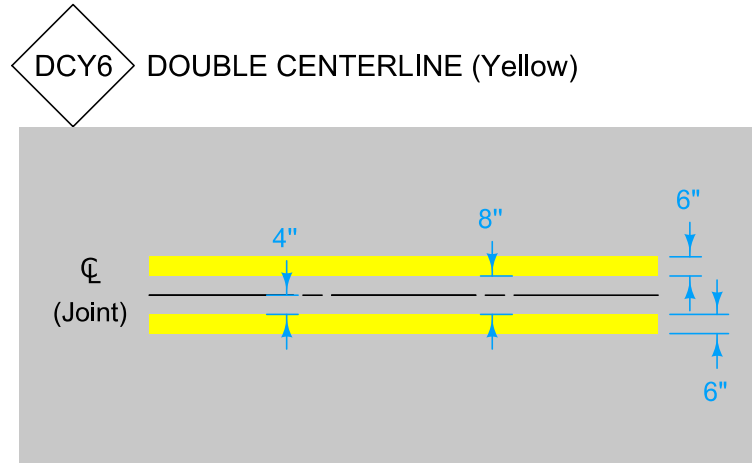
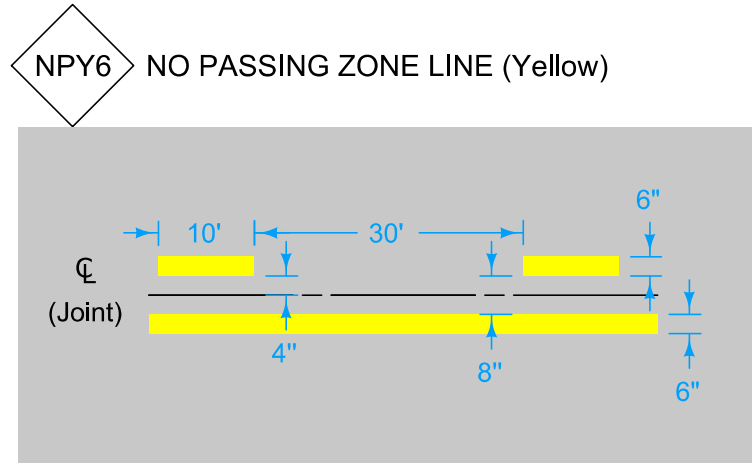

	REVISION
	5 10-15-24
STANDARD ROAD PLAN	
PM-110	
SHEET 2 of 4	
REVISIONS: Added note about primary and secondary roads.	
APPROVED BY DESIGN METHODS ENGINEER	
LINE TYPES	

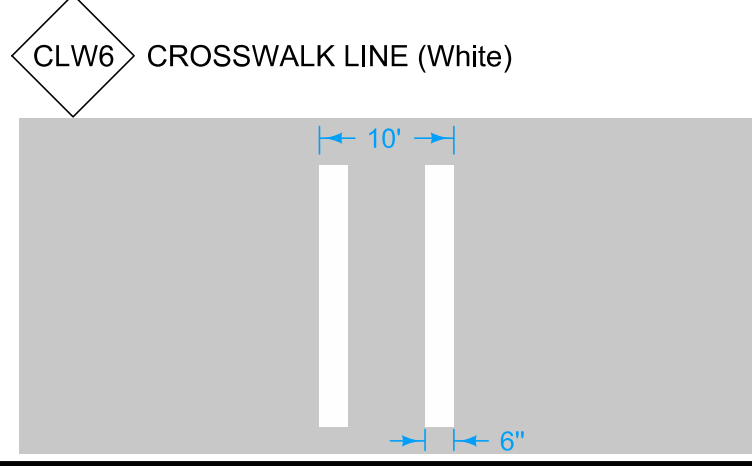
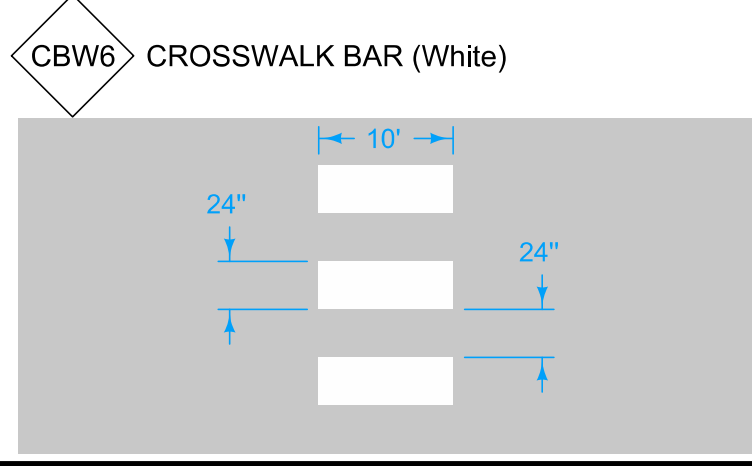
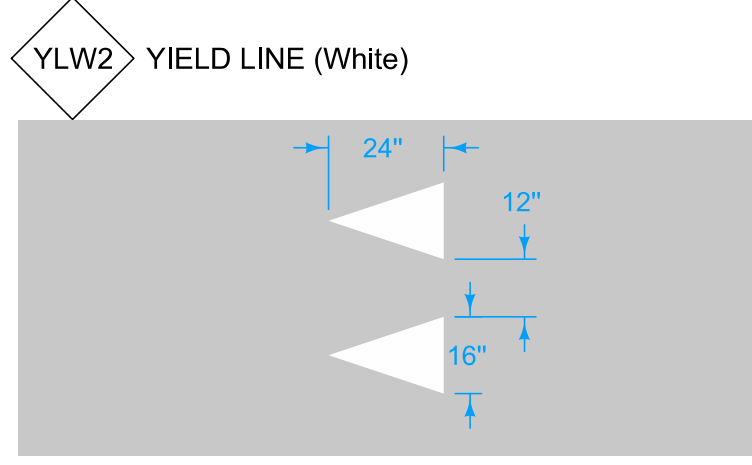
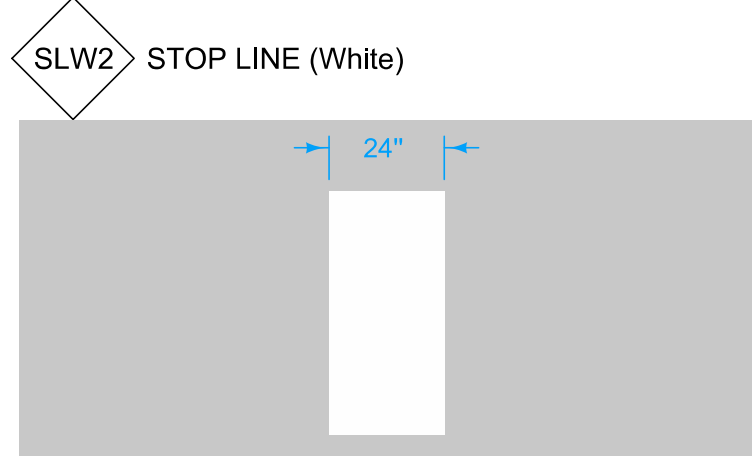
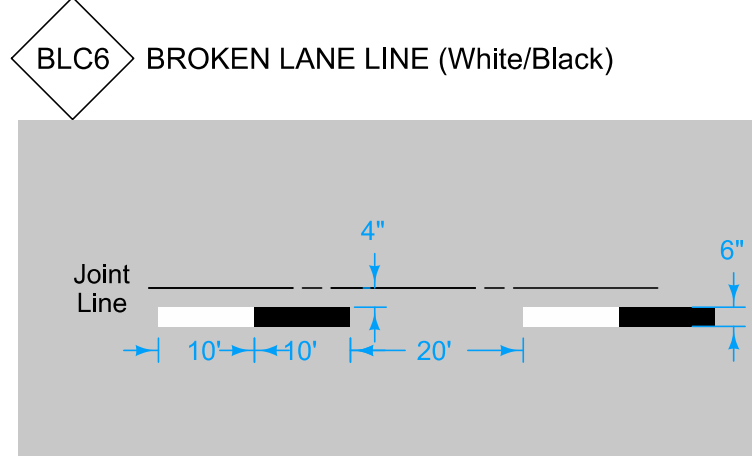
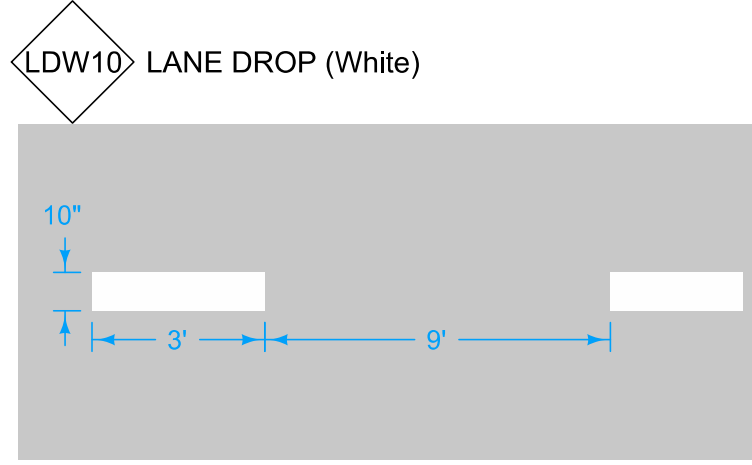
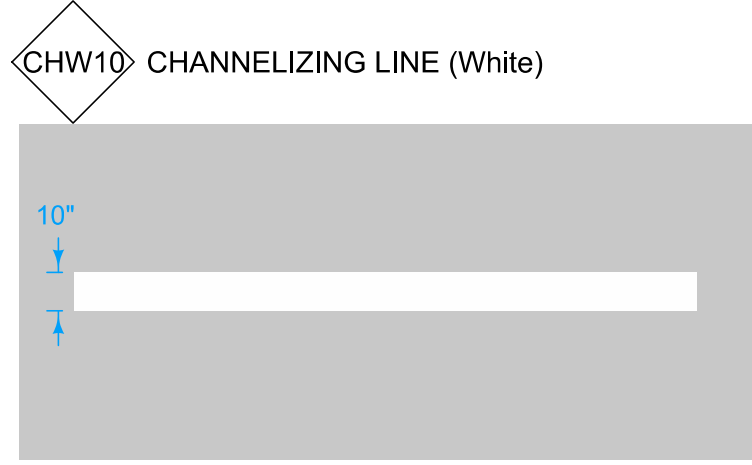
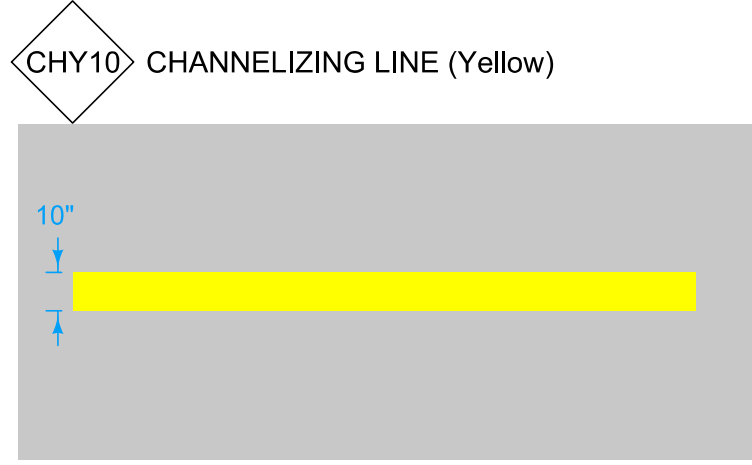
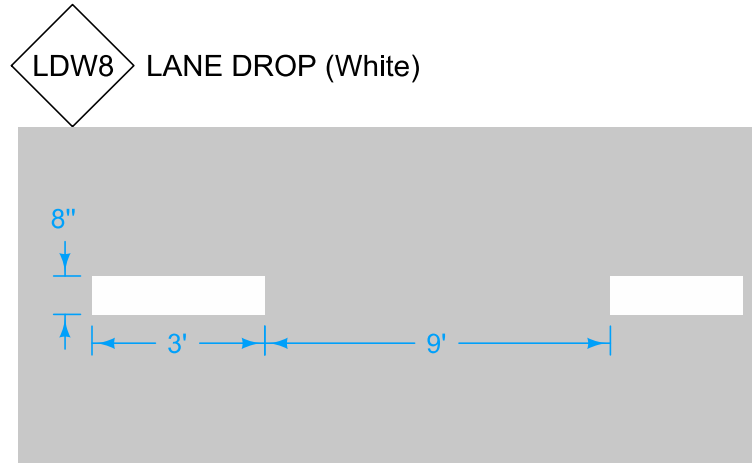
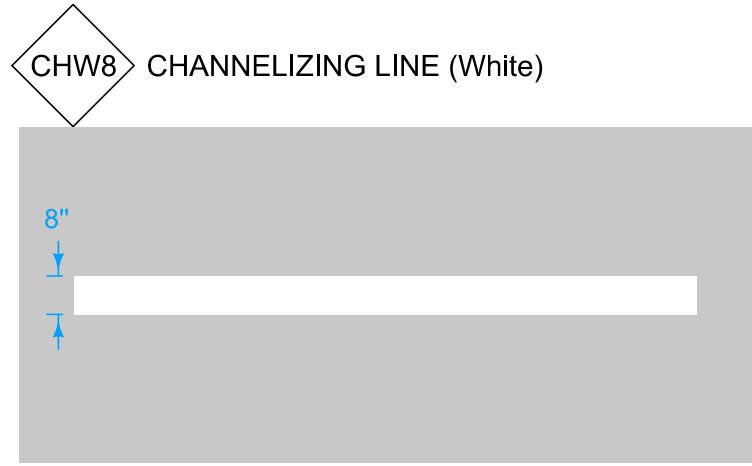
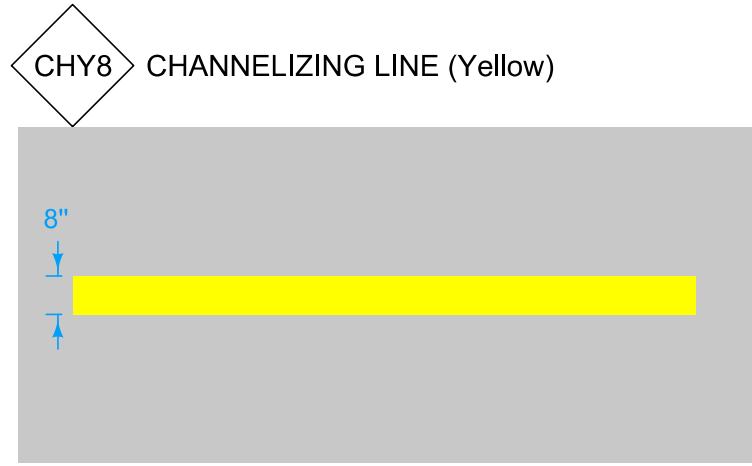

	REVISION	
	5	10-15-24
STANDARD ROAD PLAN		PM-110
		SHEET 3 of 4
REVISIONS: Added note about primary and secondary roads.		
APPROVED BY DESIGN METHODS ENGINEER		
LINE TYPES		

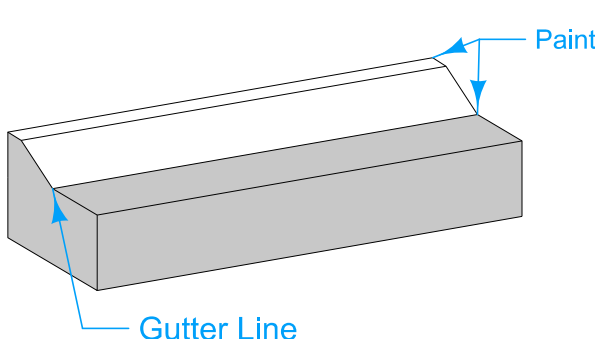
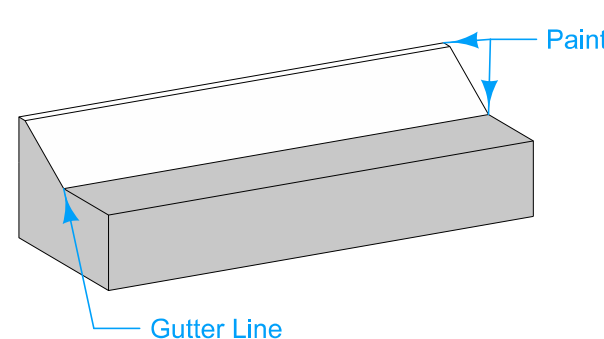
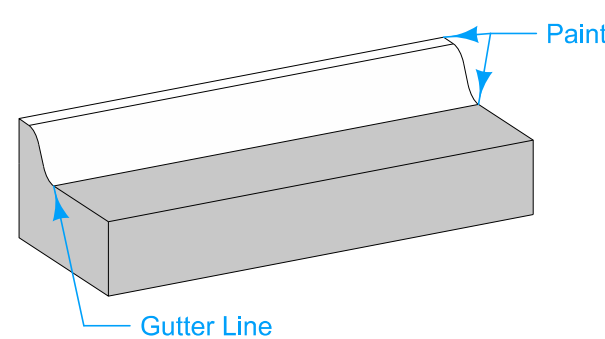
<p>SPW4 SLOPED CURB 4" (White)</p> 	<p>SPW6 SLOPED CURB 6" (White)</p> 	<p>STW6 STANDARD CURB 6" (White)</p>  <p>① Apply paint from back of curb to gutter line.</p>
--	---	---

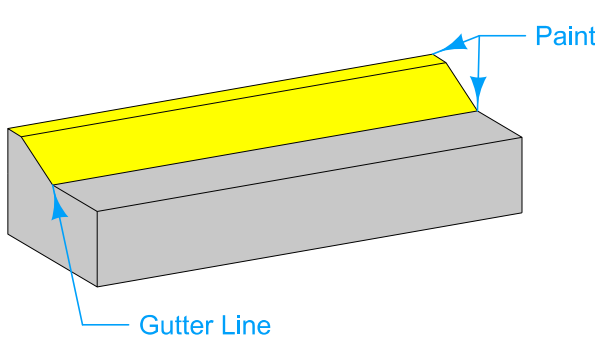
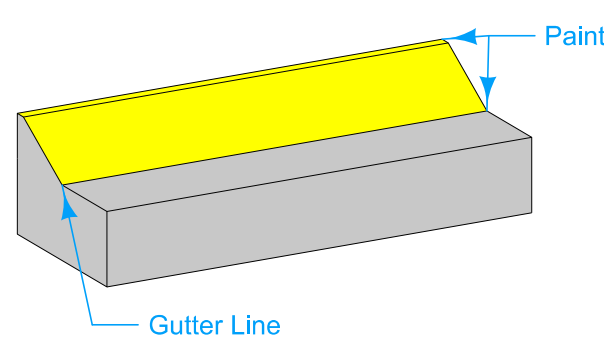
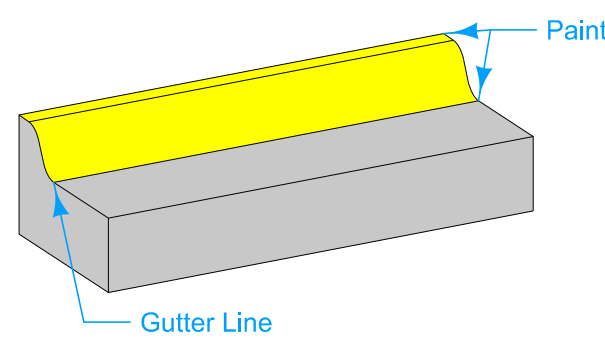
<p>SPY4 SLOPED CURB 4" (Yellow)</p> 	<p>SPY6 SLOPED CURB 6" (Yellow)</p> 	<p>STY6 STANDARD CURB 6" (Yellow)</p> 
---	--	---

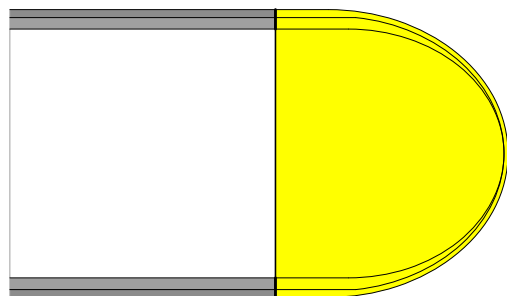
<p>MNY6 MEDIAN NOSE (Yellow)</p> 		
--	--	--

 <p>STANDARD ROAD PLAN</p>	<p>REVISION 5 10-15-24</p>
	<p>PM-110 SHEET 4 of 4</p>
<p>REVISIONS: Added note about primary and secondary roads.</p>	
<p><i>Steve Miller</i> APPROVED BY DESIGN METHODS ENGINEER</p>	
<p>LINE TYPES</p>	