

Layouts shown are for typical installations. Drawings are oriented to represent direction of traffic moving from left to right.

Center markings within the lane.

All dimensions shown are nominal. For proper proportion details, see current MUTCD Standard Highway Signs and Markings booklet.

Pavement word, symbol, and arrow markings are to be proportionally scaled to fit within the width of the facility upon which they are applied.

Except for the SCHOOL word marking, all markings are to be no more than one lane in width.

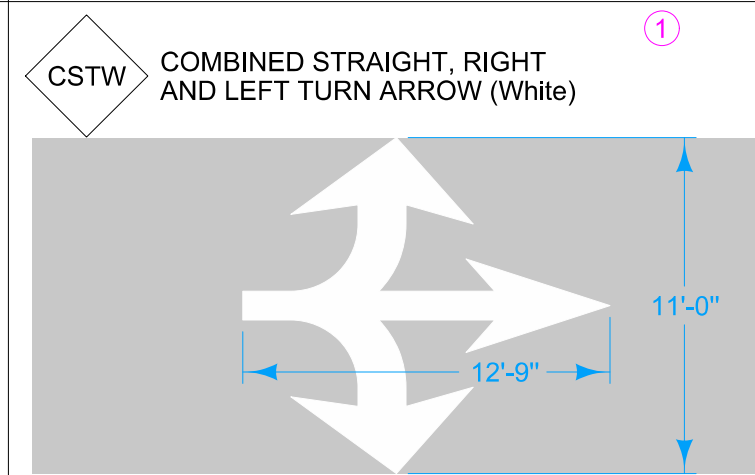
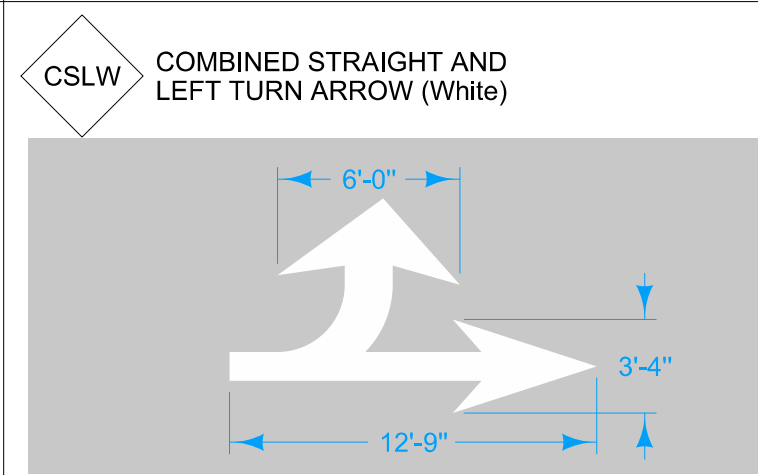
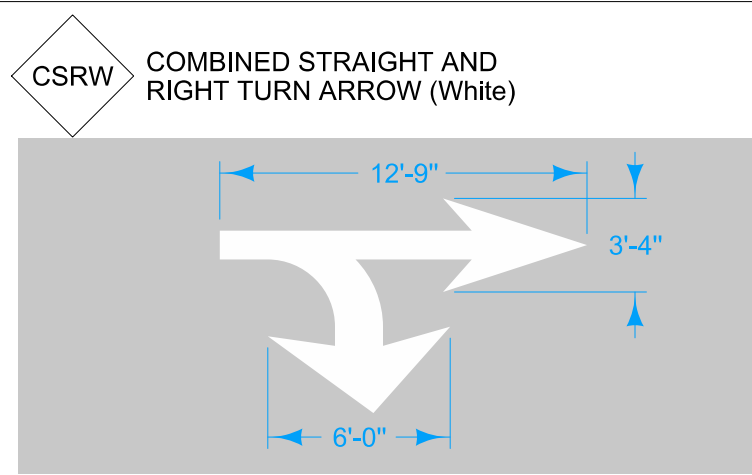

① Add template for Right Turn Arrow (RTAW) to Left Turn Arrow (LTAW) or Combined Straight and Left Turn Arrow (CSLW) to create new templates.

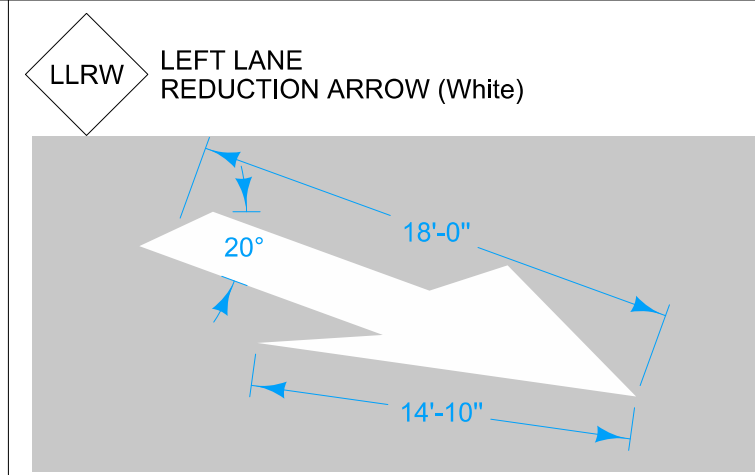
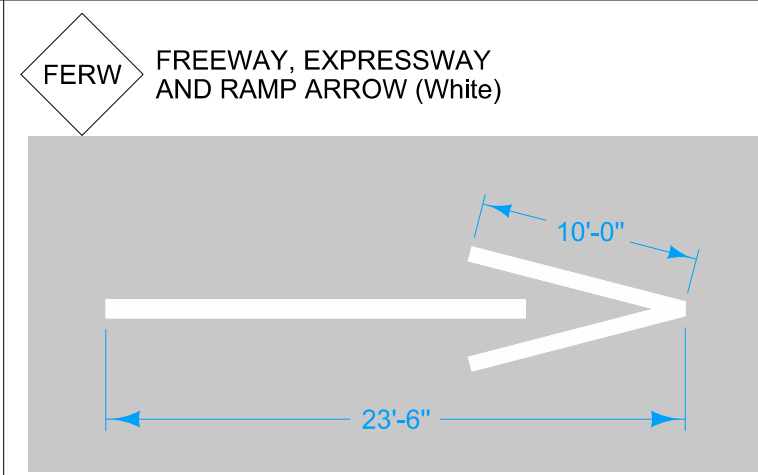
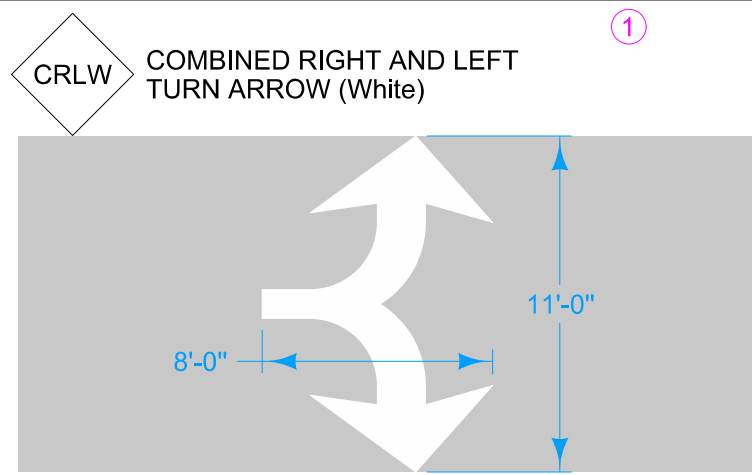

Possible Contract Item:
Pavement Marking Symbols and Legends Items

Possible Tabulation:
108-29

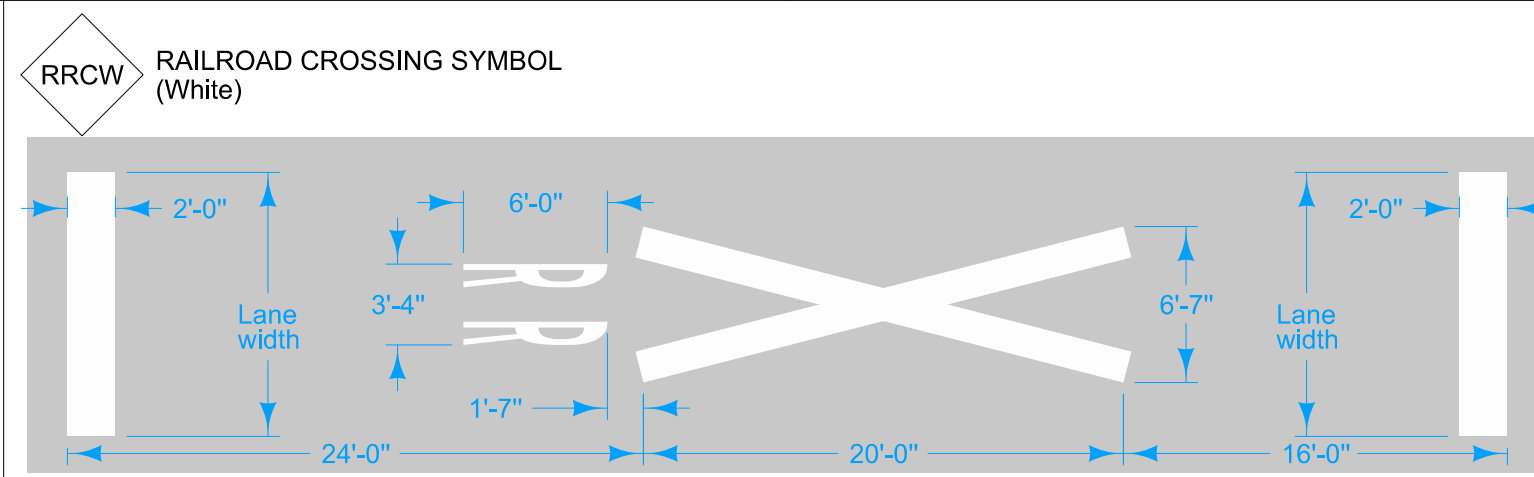
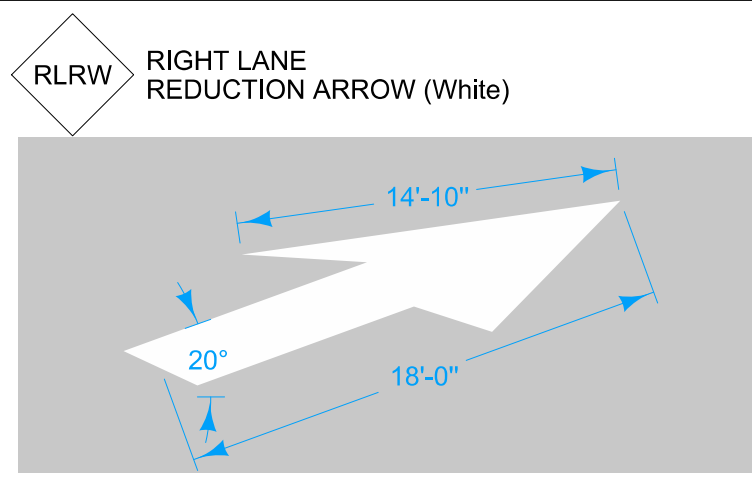

	REVISION	
	4	04-21-20
	<h2>PM-111</h2>	
STANDARD ROAD PLAN		
SHEET 1 of 2		
REVISIONS: Added SLSW.		
APPROVED BY DESIGN METHODS ENGINEER		
<h3>SYMBOLS AND LEGENDS</h3>		

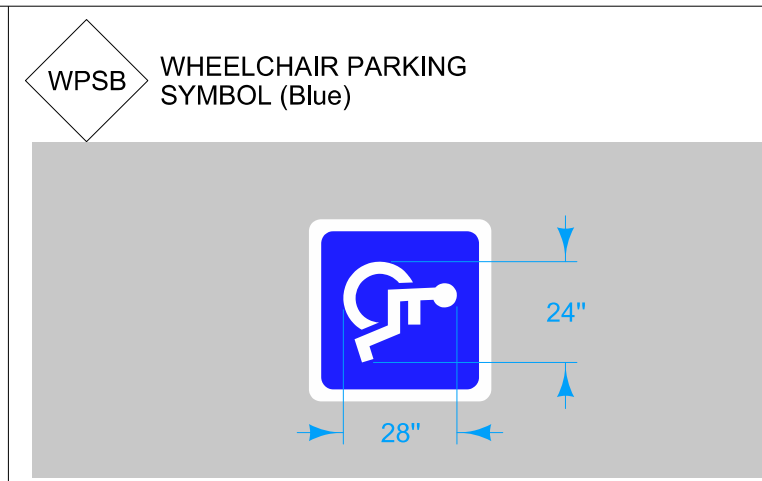
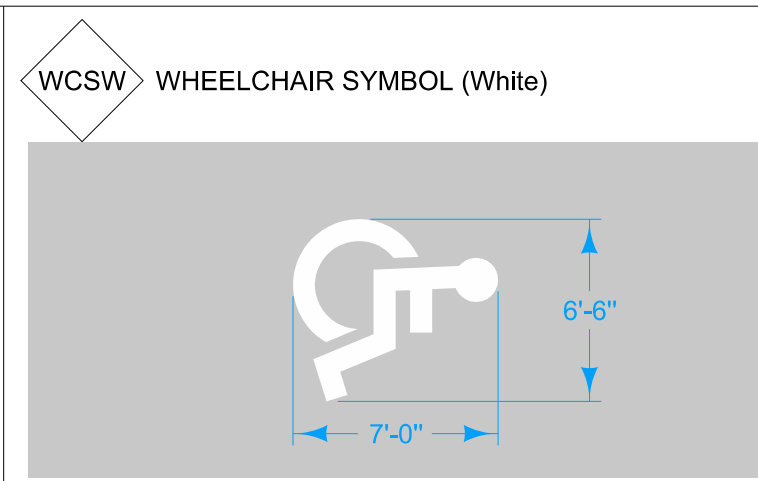
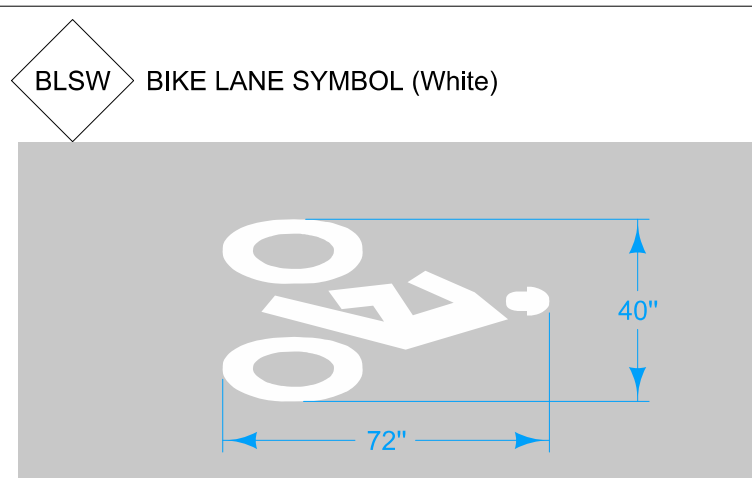

② When placed across one lane, use the smaller dimensions shown. When placed across two lanes, use the larger dimensions shown.

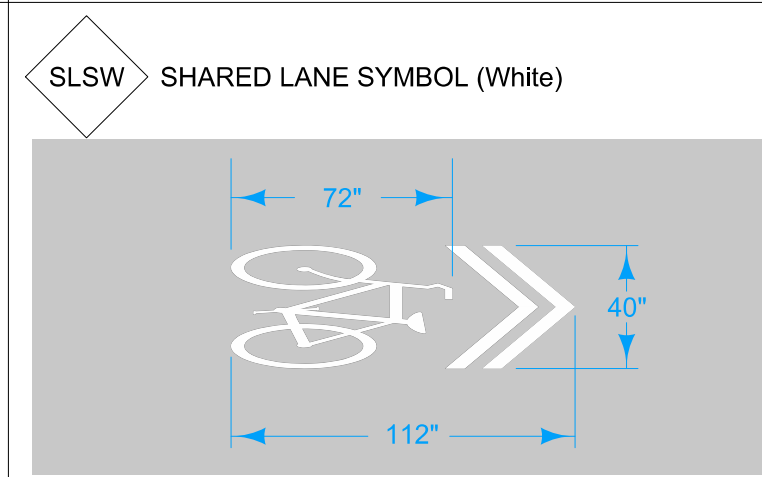
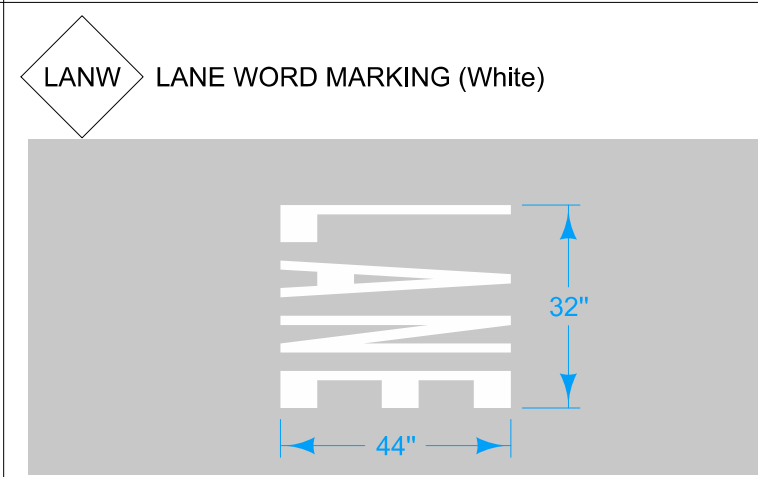
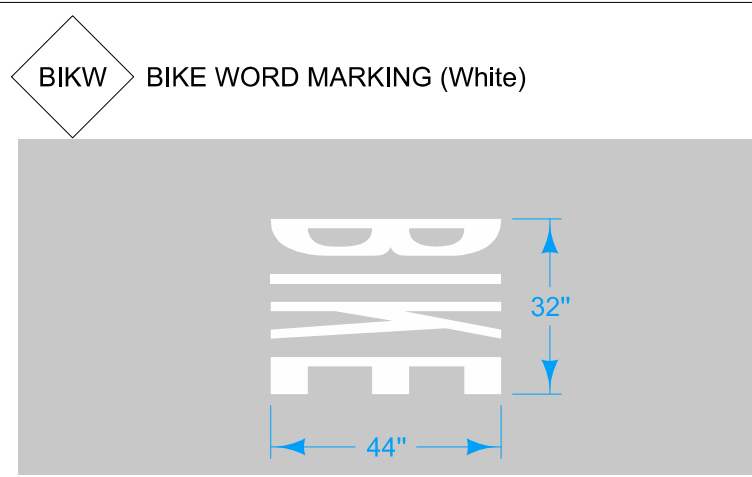
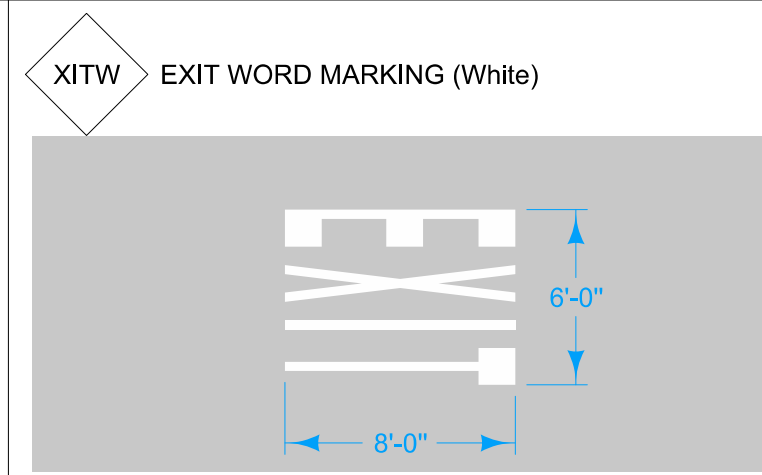
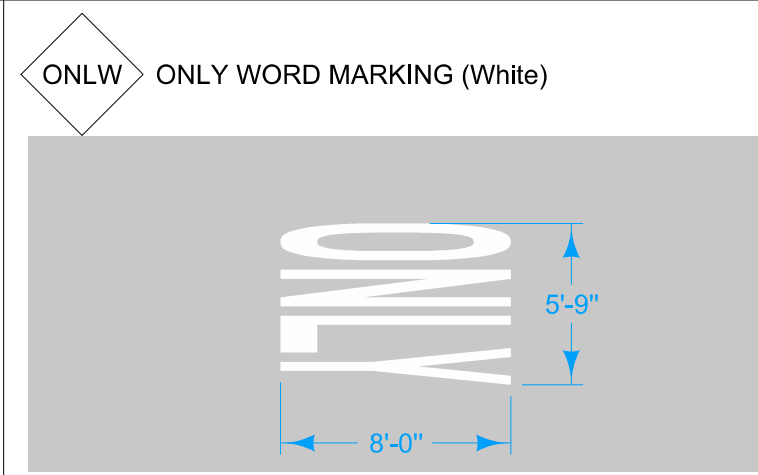
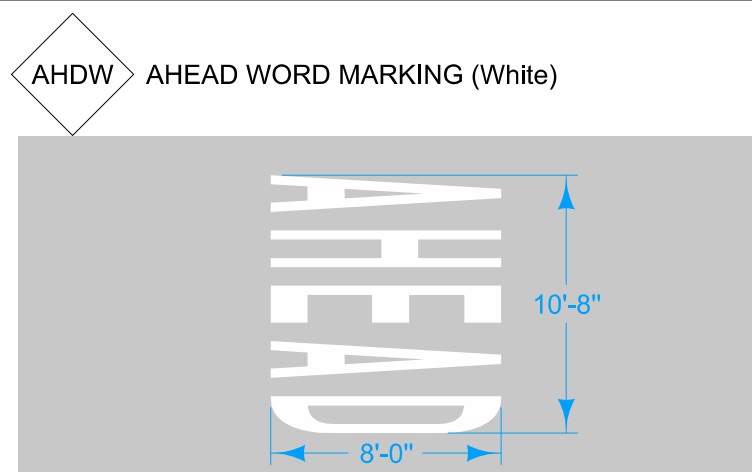
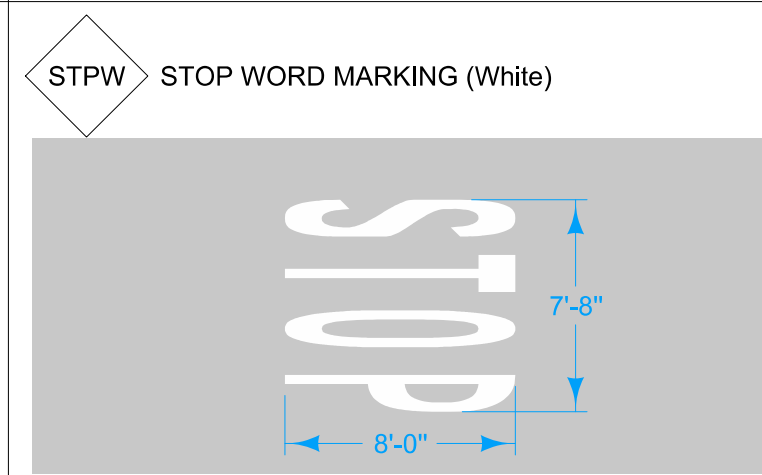
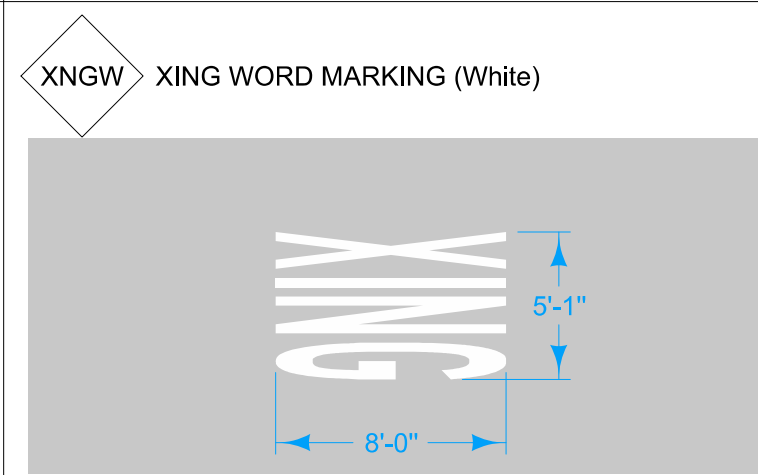
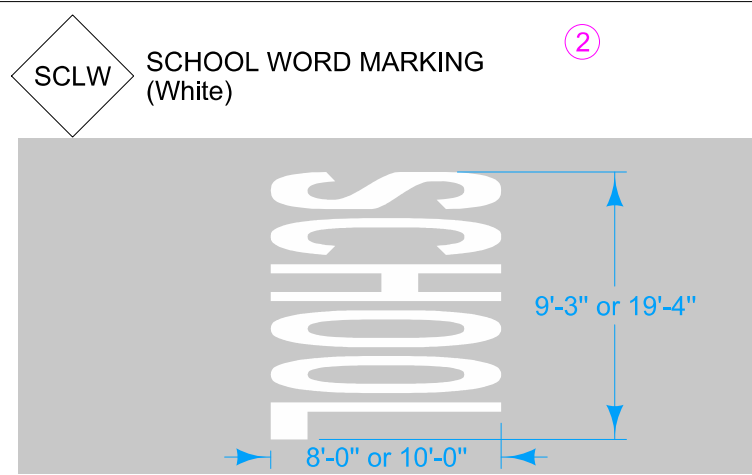

<p>STANDARD ROAD PLAN</p> <p>REVISIONS: Added SLSW.</p> <p><i>Steve Miller</i> APPROVED BY DESIGN METHODS ENGINEER</p> <p>SYMBOLS AND LEGENDS</p>	REVISION
	4 04-21-20
	PM-111 SHEET 2 of 2