

TRANSITION DETAILS - TANGENT TO CURVE

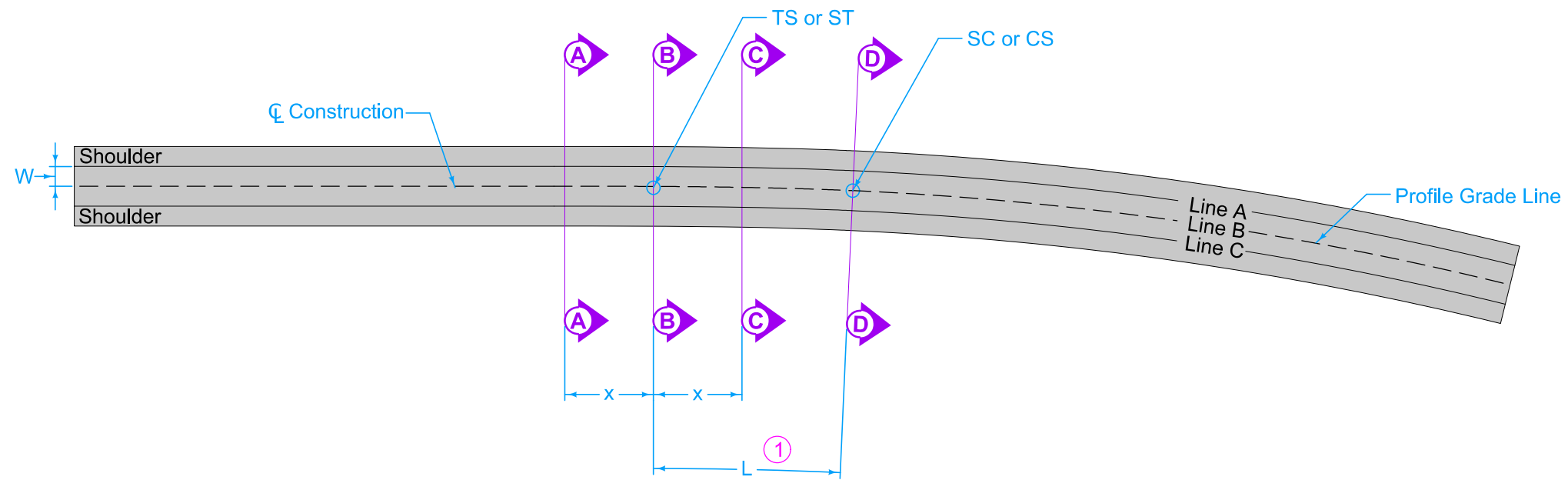

TRANSITION DETAILS - SPIRAL CURVE

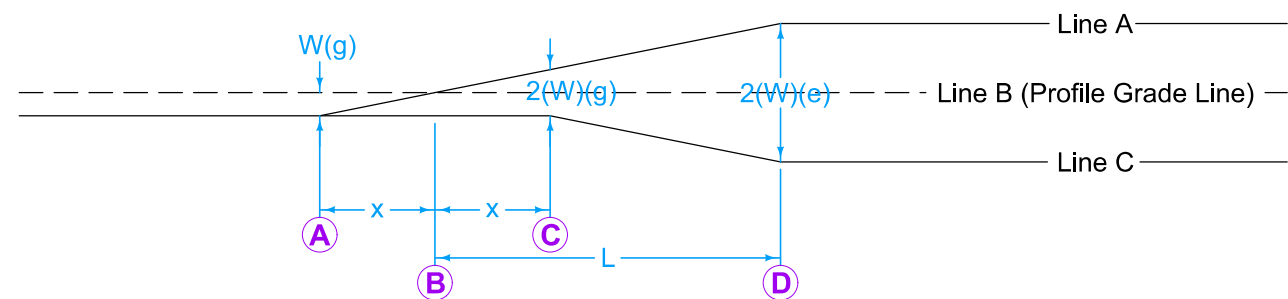

DIAGRAMMATIC PROFILES OF THE PAVEMENT EDGE LINES

Refer to specific curve data contained in project plans for tangent runoff length (x), runoff length (L) and full superelevation (e).

When spiral curve transitions are not required:
Place 70% of full superelevation at the PC and PT
Place 30% of the runoff length within the curve.

Unless otherwise specified, all lengths are measured along the centerline of construction.

Superelevations on this standard are shown for curves to the right. Curves to the left are a mirror image of what is shown.

Smooth curves should be established at the time of construction at sections A-D along the profile edges of lines A-C.

Axis of rotation coincides with profile grade location.
 $m = 30\%$ of Runoff Length (L)

$W = 12'$ Regardless of Pavement Width

$g =$ Normal Cross Slope (2%)

$L =$ Distance to Change Cross Slope from 0% to e

$e =$ Superelevation Rate

$x =$ Distance to Change Cross Slope from 0% to 2%

$s =$ Normal Shoulder Slope

① Spiral curve length coincides with runoff length (L)

Possible Tabulation:
101-18

	REVISION	
	3	04-15-25
STANDARD ROAD PLAN		PV-301
		SHEET 1 of 2
REVISIONS: Corrected spelling.		
 APPROVED BY DESIGN METHODS ENGINEER		
SUPERELEVATION DETAILS TWO LANE ROADWAY		

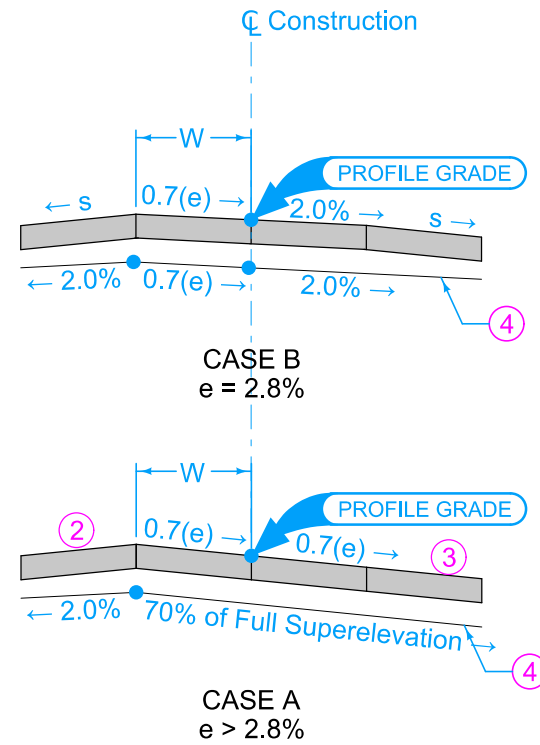
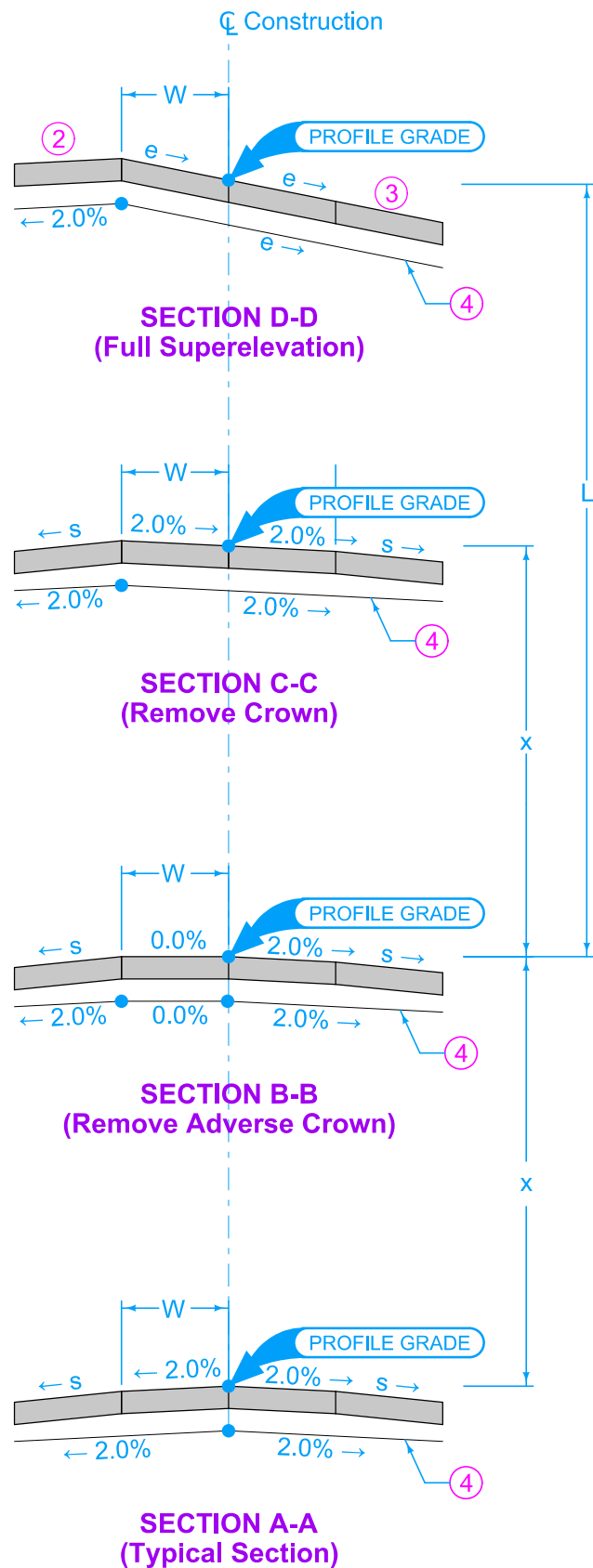

SECTION AT THE PC OR PT

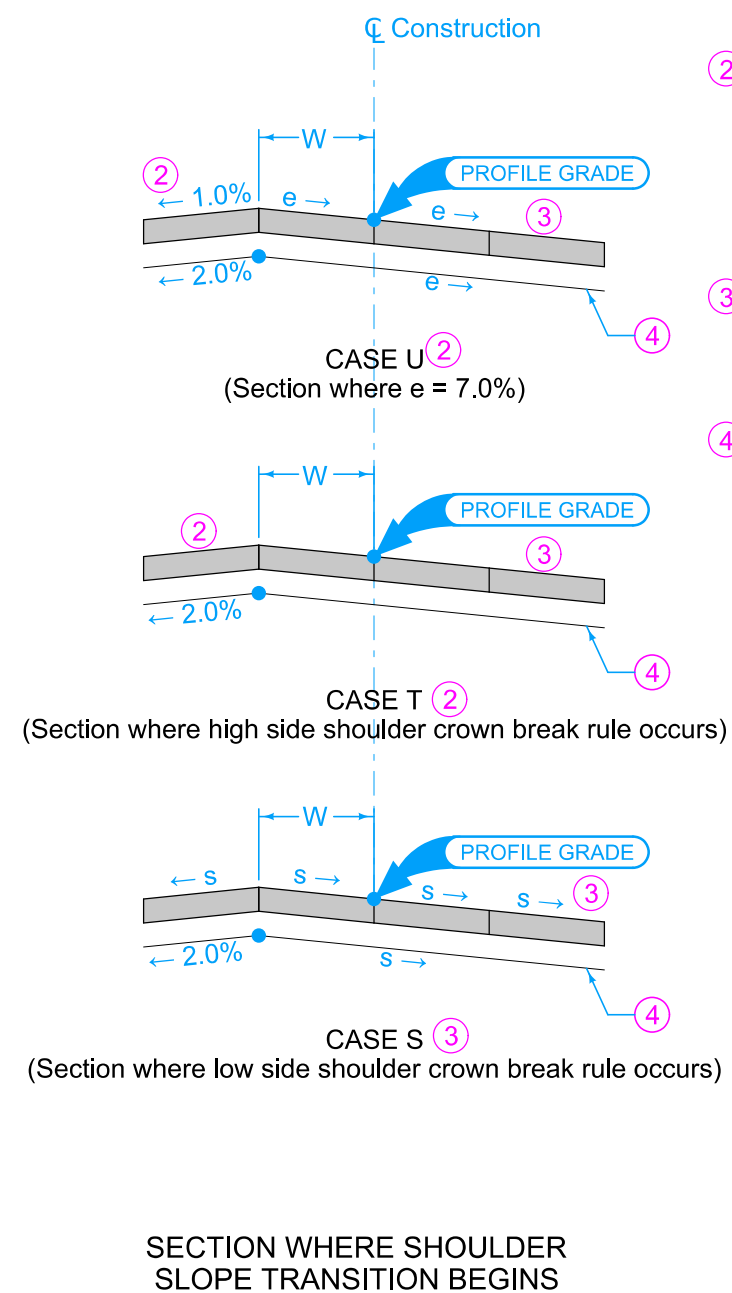

- ② High Side Shoulder: Maintain normal shoulder cross slope (s), until the cross slope break with the adjacent pavement reaches 8.0%. Maintain 8% breakover until superelevation rate reaches 7%. If superelevation rate exceeds 7.0%, maintain a 1% shoulder cross slope away from the adjacent pavement.
- ③ Low Side Shoulder: Maintain normal shoulder cross slope (s) until the adjacent pavement slope equals s , then slope the shoulder at the same cross slope as the adjacent pavement.
- ④ Subgrade Surface: Subgrade surface cross slope parallel to pavement surface cross slope.

	REVISION	
	3	04-15-25
STANDARD ROAD PLAN		PV-301
REVISIONS: Corrected spelling.		SHEET 2 of 2
 APPROVED BY DESIGN METHODS ENGINEER		
SUPERELEVATION DETAILS TWO LANE ROADWAY		