

# Horizontal Intersection Design: Rural Two-Lane

Design Manual  
Chapter 6  
Geometric Design

Originally Issued: 09-01-95  
Revised: 06-18-04

This section provides a procedure for designing intersections on rural two-lane highways.

The procedure should *not* be used for:

- intersections on four-lane highways.
- urban intersections.
- intersections on transitional highways (where speeds are slowing down or speeding up as a rural roadway transitions to or from an urban or more-congested environment).
- signalized intersections. Signal warrants should be checked in the *Manual on Uniform Traffic Control Devices*. For signalized intersections, use *Highway Capacity Manual* procedures to determine lane configuration (some software packages incorporate procedures similar to the *Highway Capacity Manual*. These are also acceptable).

Before designing a rural intersection following these procedures, make sure there is adequate horizontal sight distance (see Section 6A-4). If sight distance requirements are not met, the profile grade may be changed or the intersection relocated.

## Auxiliary Lane Warrants

The auxiliary lane warrants described in this section do *not* apply to:

- intersections on four-lane highways.
- intersections where there is a stop condition on the mainline.

Warrants are determined by plotting the thru traffic volume and the turning traffic volume on Figure 1 for rural two-lane highways. Traffic volumes should be adjusted for the percentage of heavy vehicles. Divide each approach volume by the appropriate correction factor from Table 1 before plotting on Figure 1.

Design year ADT is used to determine left-turn lane warrants. A left-turn lane provides a full-width lane for vehicle storage. If a left-turn lane is warranted on only one approach of the mainline at a four-way intersection, a left-turn lane should be provided on the opposite approach as well.

Warrants for right-turn lanes are based upon present ADT and are divided into two categories—major and minor. A major right-turn lane provides a full-width lane for deceleration from the design speed on the mainline. A minor right-turn lane assumes vehicles will decelerate to 30 mph on the mainline before entering the auxiliary lane.

Meeting warrants does not necessitate installing an auxiliary lane. Designers should use these warrants along with other project and site specific factors, such as operational considerations, proximity to urban or recreational areas, etc. to determine if an auxiliary lane should be installed. The decision process should be documented and placed in the project file.

# Rural Two-Lane Highways

## Rural Two-Lane Highways

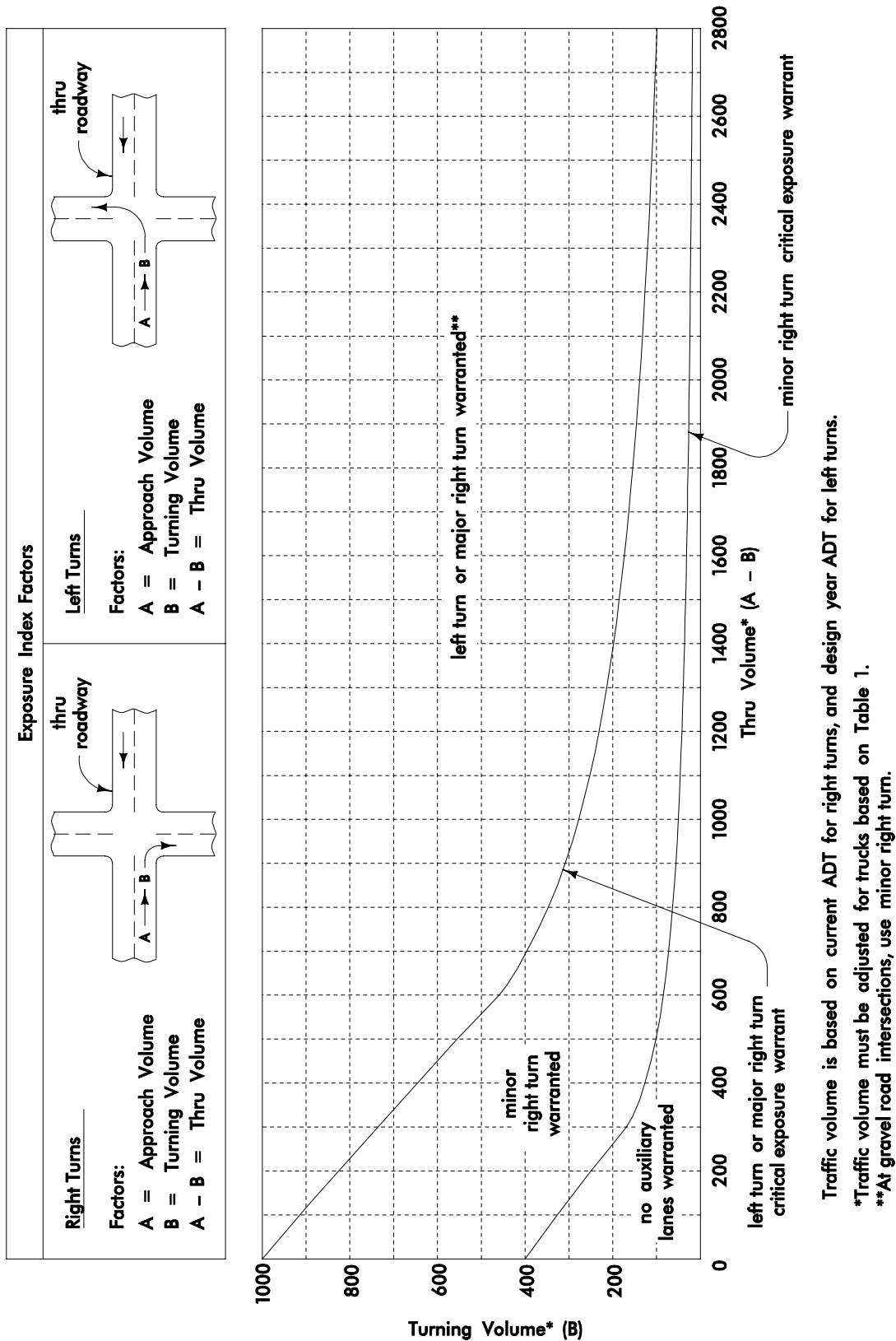

Figure 1: Rural two-lane highway auxiliary lane warrants.

**Table 1: Truck adjustment factors. Divide each approach volume by the appropriate factor.**

Truck %	Correction Factor	Truck %	Correction Factor	Truck %	Correction Factor	Truck %	Correction Factor
0	1.05	6	0.99	12	0.93	18	0.87
1	1.04	7	0.98	13	0.92	19	0.86
2	1.03	8	0.97	14	0.91	20	0.85
3	1.02	9	0.96	15	0.90	25	0.80
4	1.01	10	0.95	16	0.89	30	0.75
5	1.00	11	0.94	17	0.88	35	0.70

## Auxiliary Lane Design

### Left-Turn Lane Design

If a left-turn lane is warranted, begin by selecting the median width. Because curbs are not desirable on high-speed facilities, painted medians are normally used. For painted medians, the minimum median width is 16 feet (4.8 meters). This accommodates a 12-foot (3.6-meter) turn lane and a 4-foot (1.2 meter) minimum width median between the left-turn lane and the opposing traffic lane.

The lane length and taper ratio are based upon storage requirements—the lane is not designed for deceleration. Develop the lane with a taper at a 10:1 ratio. Use Figure 2 to determine the length of the left-turn lane. The minimum length is 150 feet (45 meters) and the length should be increased in 25-foot (7.5-meter) increments (25 feet 7.5 meters per vehicle is provided for storage).

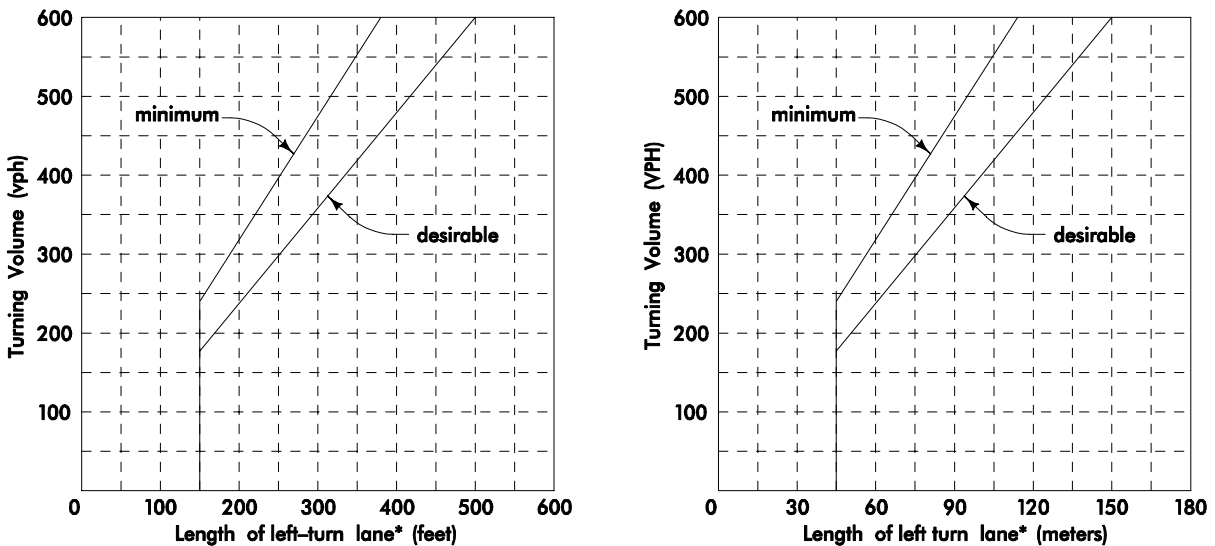

\*Table value is rounded up to the nearest 25' (7.5 m) increment for design. Minimum length is 150 feet (45 meters)

**Figure 2:** Left-turn lane storage length.

Full median width should be maintained throughout the storage lane length and the taper length. Reverse curves with 12,000-foot radii should be used to transition back to a two-lane roadway beyond the intersection (see Figure 3).

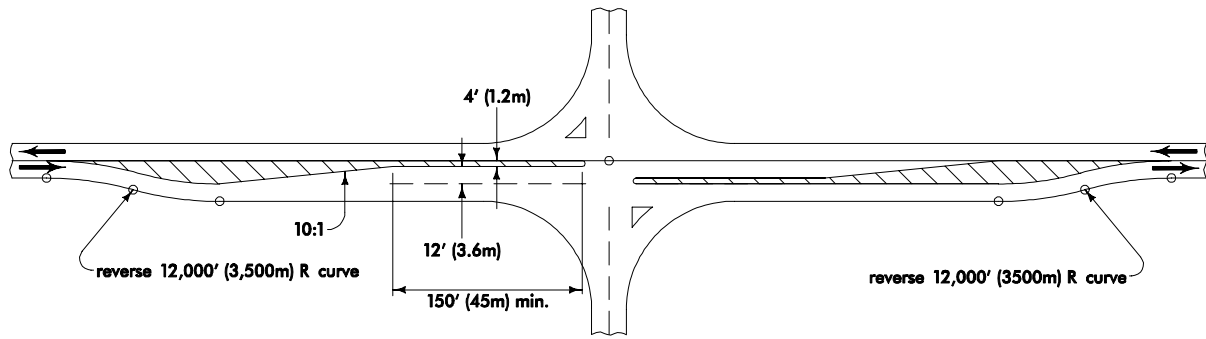

**Figure 3:** Rural channelized intersection.

To provide optimum operating characteristics for the approaching driver, the centerlines of the approaching legs can be offset by the median width (see Figure 4).

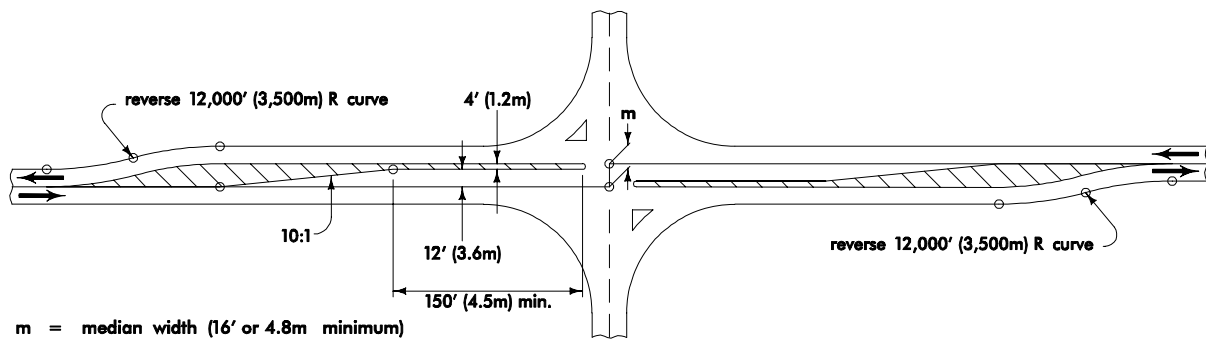

**Figure 4:** Rural channelized intersection with centerlines offset.

### Major Right-Turn Lane Design

A major right-turn lane (see Figures 5 and 6) provides for full deceleration from the design speed on the mainline to the speed allowed by the control radius at the intersection. The control radius is the shortest radius of the intersection return. Use Table 2 to determine the length of the deceleration lane—the required length is a function of the design speed and the control radius. Correct for grades greater than 3% by multiplying the table value by the appropriate correction factor from Table 3. The deceleration lane length does not include the taper or any portion of the intersection return.

**Table 2: Deceleration lane lengths for major right-turn lanes.**

**English units**

warrant	design speed (mph)	taper ratio	deceleration lane length (L)* (ft)				
major	40	15:1	295	280	265	235	185
	45		350	340	325	295	250
	50		405	395	385	355	315
	55		455	450	440	410	380
	60		500	490	480	460	430
	65		540	530	520	500	470
	70		590	580	570	550	520
control radius (ft)			50	70	90	150	230

**metric units**

warrant	design speed (km/h)	taper ratio	deceleration lane length (L)* (m)				
major	60	15:1	90	85	80	65	55
	70		105	100	95	85	70
	80		125	120	115	100	90
	90		140	140	135	120	110
	100		165	160	155	145	135
	110		180	175	170	160	150
	120		195	190	185	175	170
control radius (m)			10	20	25	50	80

\*interpolate directly for intermediate control radii and design speeds

Use parallel type  
  Option—parallel or taper  
  Use taper type

**Table 3: Gradient factor. Multiply the correction factor for grade by the deceleration lane length.**

	upgrade	downgrade
3% to 4%	0.9	1.2
5% to 6%	0.8	1.35

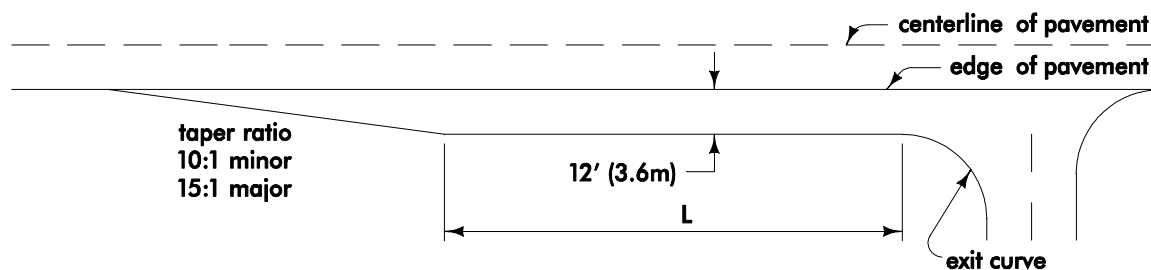

**Figure 5:** Parallel type right-turn deceleration lane—for major or minor right-turn lanes.

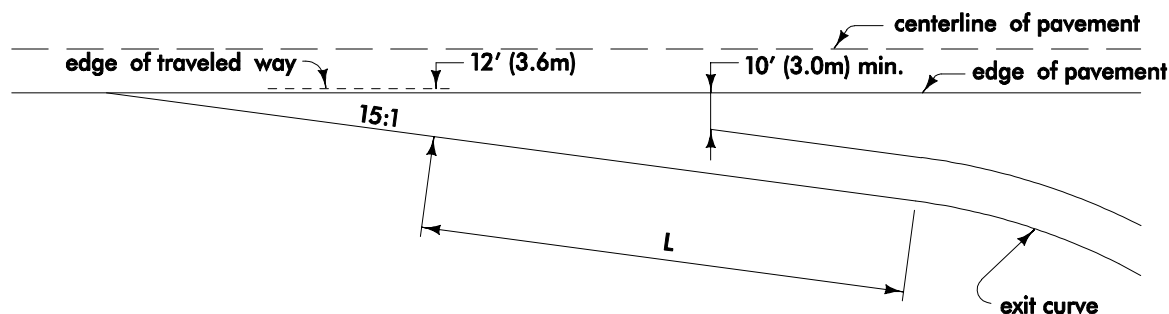

**Figure:** Taper type right-turn deceleration lane—for major right-turn lanes.

### Minor Right-Turn Lane Design

A minor right-turn lane provides for deceleration from 30 mph on the mainline to the speed allowed by the control radius at the intersection. When a minor right-turn lane is warranted use a design speed of 30 mph and a parallel-type layout with a 10:1 taper ratio (see Figure 5). The lane length can be determined from Table 4. Apply the appropriate correction factor for grades greater than 3% using Table 3. As with major right-turn lanes, the lane length does not include the taper or any portion of the intersection return. A 4-foot (1.2-meter) shoulder should be constructed adjacent to the deceleration lane, using the same material as the mainline shoulder.

**Table 4: Deceleration lane lengths for minor right-turn lanes.**

#### English units

warrant	design speed (mph)	taper ratio	deceleration length (L)* (ft)			
minor	30	10:1	185	175	160	140
control radius (ft)			50	70	90	150

#### metric units

warrant	design speed (km/h)	taper ratio	deceleration lane length (L)* (m)			
minor	50	10:1	70	65	60	45
control radius (m)			10	20	25	50

\*interpolate directly for intermediate control radii

### Intersections with Gravel Sideroads

Left-turn warrants and design for intersections with gravel sideroads are the same as with paved sideroads.

When the intersection of a rural two-lane highway with a gravel sideroad warrants a right-turn lane, only **minor** right-turn lane criteria should be used.

Continue the deceleration lane pavement through the intersection to the point where the return radius meets the shoulder line of the deceleration lane (see Point X on Figure 7). At this point, begin the lane drop taper at a 10:1.

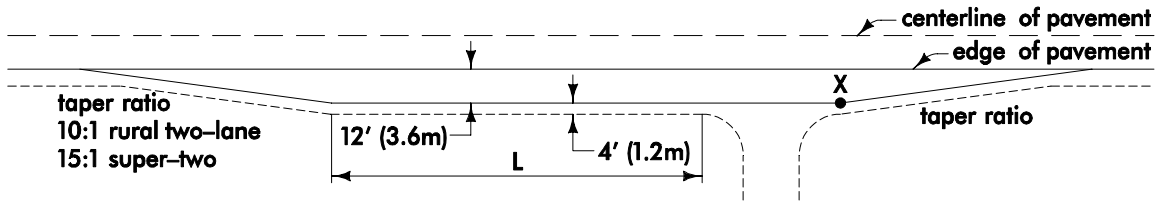

**Figure 7:** Deceleration lane.

## Stop-Sign Islands

Stop-sign islands are used to regulate traffic, aid the driver in negotiating the intersection, and protect and store crossing and turning vehicles.

Stop-sign islands are required on all paved sideroad approaches to the thru route. However, when the sideroad design year ADT is less than 100 vpd, the island is optional. Placement of the stop sign must meet MUTCD criteria. Therefore an island may be required even if the sideroad has less than 100 vpd in order to permit proper location of the stop sign.

Figure 8 illustrates requirements for the placement of islands. In order to command attention, the desired island size is 100 square feet (9 square meters). The minimum acceptable size for an island is 75 square feet (7 square meters).

Use 4-inch (100-millimeter) sloped curbs for stop-sign islands on rural roadways. See Section 3C-2 and Detail 6144 for more information about curbs on stop-sign islands.

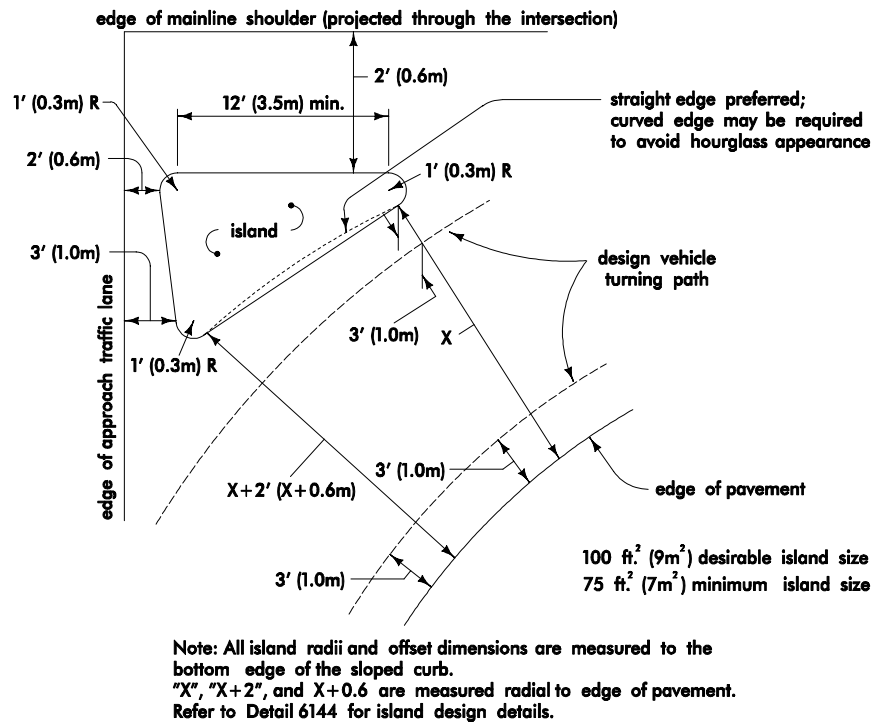

**Figure 8:** Offset requirements for intersection stop-sign island.

## Design Vehicle

The next step is to select an appropriate design vehicle. Based on a site evaluation, determine the largest vehicle that will frequently turn at the intersection (not just the occasional user). Consider:

- location of the intersection in relation to the surrounding land use (factories, parks, schools, etc.)
- the type of intersecting roadway (primary or secondary road, entrance, etc.)

Normally, the WB-50, the WB-62, or the WB-67 truck tractor-semitrailer combinations are appropriate at the intersection of two primary roadways. At other locations, such as non-primary, secondary, state park or institutional roads, the appropriate design vehicle may be a single-unit truck, bus or RV. Refer to Chapter 2 in AASHTO's *A Policy on Geometric Design of Highways and Streets* for more information about selecting a design vehicle.

## Turning Path Placement

After determining the lane configuration and the design vehicle, select a turning-path radius and draw the turning path on a plan view of the intersection.

The selected design vehicle turning path should be centered within the traffic lane at the beginning and the end of the turn. Connect the entry and exit paths with a single turning radius, which cannot be shorter than AASHTO's minimum radius guidelines (see Exhibit 2-2 in *A Policy on Geometric Design of Highways and Streets*).

### Left Turns

For most left turns, a 50-foot (15-meter) turning path radius is preferable. However, a longer radius may be used with very obtuse angles. Radius increments of 25 feet (5 meters) are preferred but 5-foot (1-meter) increments are acceptable.

In addition, the turning path for a left turn may swing wide to provide clearance for a vehicle waiting at the stop bar. Figure 9 on the next page illustrates a turning path for this situation.

### Right Turns

At intersections with little or no skew, a 75-foot (25-meter) turning path radius for right turns is suitable. If the approach requires a stop-sign island, the turning radius may need to be increased to accommodate the island (see Figure 8).

Intersection skew may justify increasing or decreasing the turning path radius. Any alteration in radius should occur in preferred 25-foot (5-meter) increments or minimum 5-foot (1-meter) increments.

Approximately 3 feet (1 meter) of clearance should be maintained from median noses, islands, faces of curb, and pavement edges. Where encroachment or insufficient clearances exist for either left or right turns, the designer may select a different turning path radius or modify the geometrics of the intersection. This can be done by changing one or a combination of the following:

- the lane alignment (for example, by widening the median).
- the horizontal alignment of the mainline.
- the skew angle of the intersection. See Section 6A-8 for the Department's policy on the skew angle of intersections.

Carefully study the various options to determine the best solution for your situation.

The next step in the process is to graphically lay out the returns. When designing without the aid of CADD, draw the intersection at 20 scale in English or 250 scale metric. A drawing at this scale is necessary for accuracy.

---



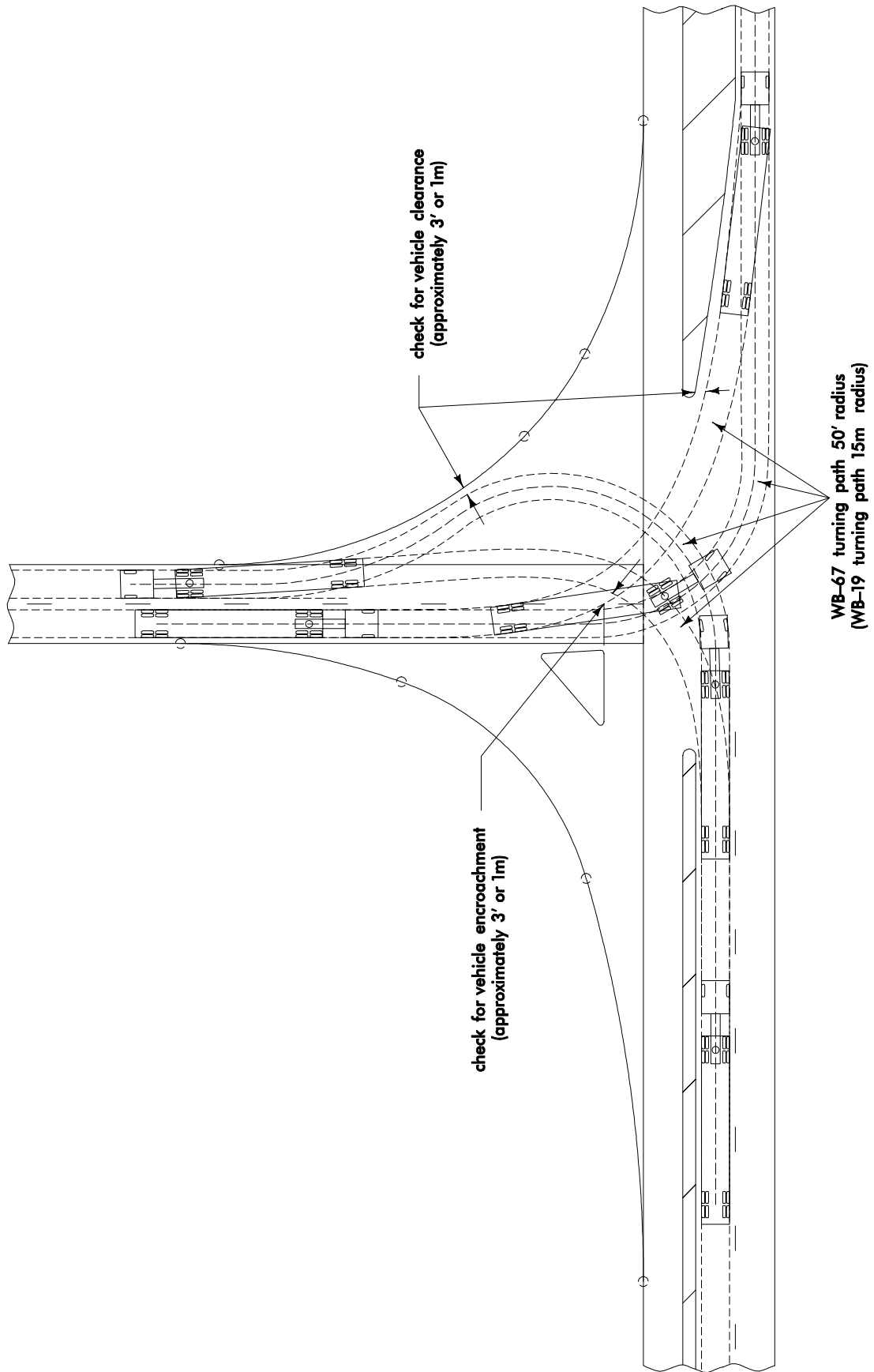

**Figure 9:** Left-turn movements for channelized intersection.

## Graphic Layout of Return Radii

Draw the edge of pavement concentric to the turning path, at approximately 3 feet (1 meter) from the wheel path. Select return radii in 5-foot (1-meter) increments with up to three radii and/or tapers for one return (see Figures 12 and 13). Add the stop-sign island to the graphic layout (see Figure 8 for required offsets).

## Geometric Plan

Using the graphic layout as a guide, set geometric controls and calculate the return geometry. An accurate geometric plot should be checked with the turning path template to assure that the actual geometrics closely approximate the graphic layout. If necessary, adjust the geometric controls and recalculate the geometry until a close approximation of the graphic layout is achieved.

## Jointing

See Section 7A-3 for information on jointing rural intersections.

## Design Review

If the design requires review by another office or agency, the following information is required:

- a 20 scale for English units or 250 scale for metric units layout of the intersection. The selected design vehicle should be identified and the turning path shown on the layout, along with lane lines and proposed geometric data.
- design speed on the mainline and ADT traffic (including turning volumes).
- plan and profile sheets along the mainline and sideroad for distances sufficient to check sight distance at design speed.
- typical cross sections.

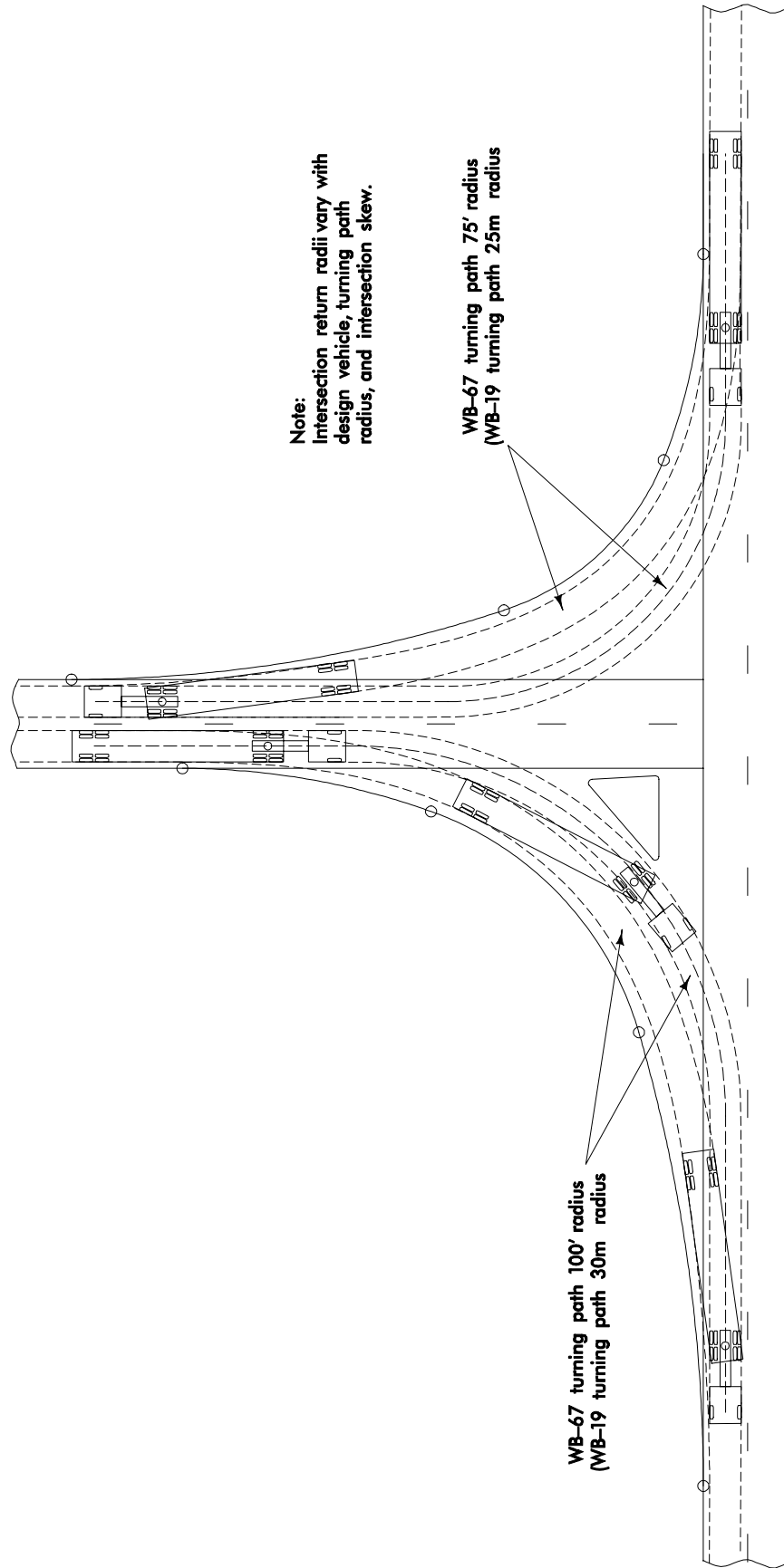

**Figure 10:** Intersection layout (little or no skew).

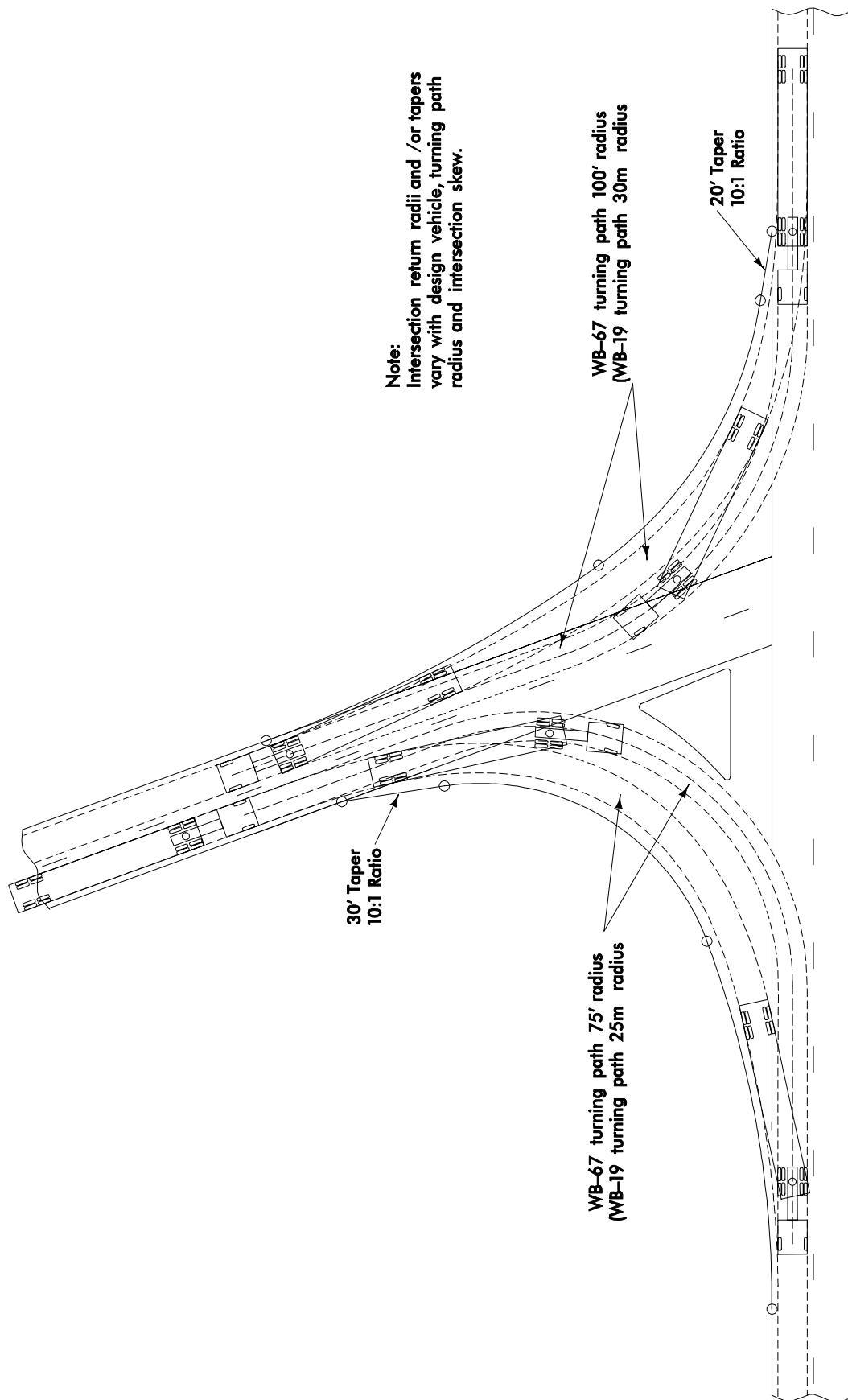

**Figure 11:** Intersection layout (skewed condition).