



TRAFFIC AND SAFETY MANUAL

Chapter 2 – Signing 2A - General

Mounting Requirements

Originally Issued: 12-17-01, Last Revised: 12-17-01

Wood Posts

Wood posts for sign installation are available from inventory in two sizes, 4" x 4" and 4"x6". Available lengths are shown in the following table.

<u>Size</u>	<u>Available Lengths</u>
4"x 4"	10', 12', and 14'
4"x 6"	16', 18', 20', 22' and 24'

If posts longer than are available are required for special situations, splicing by overlapping and bolting 2 posts together is permissible. Details on the proper method to splice posts are shown in Figure 4.

In selecting the proper size and number of posts to be used for installing a particular sign, the chart shown in Figure 1 should be used. The scale along the bottom of the chart is the horizontal dimension of the sign given in either inches or feet. In a like manner, the scale along the left edge of the chart is the vertical dimension of the sign. Enter the chart from these 2 points and project lines vertically and horizontally to the point where they intersect. For example, if the sign was 72" wide and 48" high, the resulting point is in the area where 2 – 4"x 6" posts are required. This chart was developed based on the relationships between post combinations and sign area to withstand wind load.

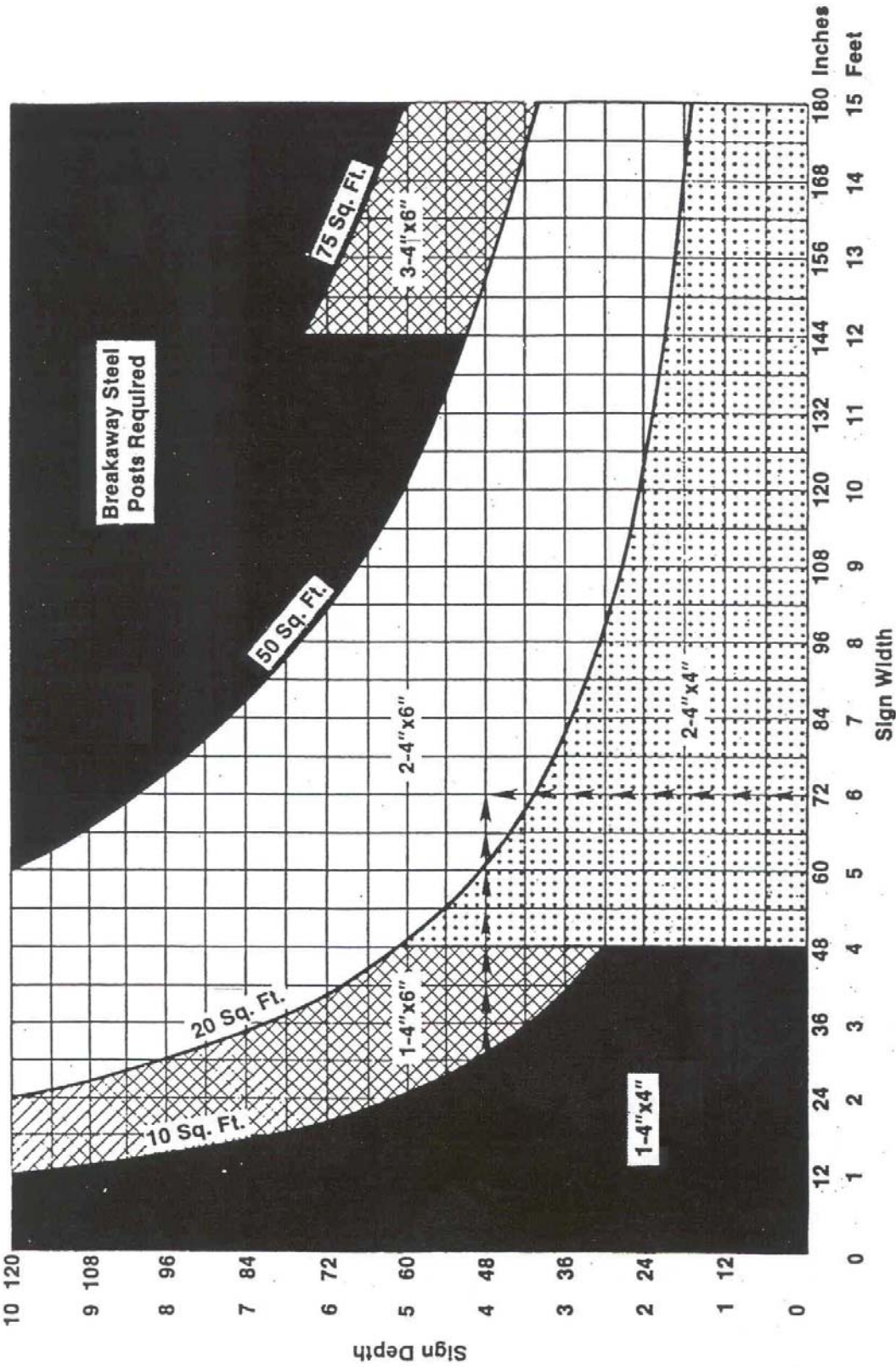

CHART FOR DETERMINATION OF SIGN POST SIZE AND NUMBER

Figure 1

Sign Area

Less Than 10 sq. ft.
10 - 20 sq. ft.
20 - 50 sq. ft.
50 -75 sq. ft.
More Than 75 sq. ft.

Post Size and Number

1 - 4"x 4" or 2 - 4"x 4"
1 - 4"x 6" or 2 - 4"x 4"
2 - 4"x 6"
3 - 4"x 6"
Steel Posts Required

For sign shapes other than rectangular, use the sign area to determine post requirements. For example, a 48" x 48" diamond shaped warning sign has 16 square feet of area and may be mounted on one 4" x 6" post.

In addition to the area requirements, two other restrictions have been established. They are (1) the maximum width of sign to be installed on a single post assembly is 4 feet for stability reasons and (2) the minimum width of sign to be installed on a 3 post assembly is 12 feet to avoid having more than 2 posts in an 8 foot path for safety reasons. The latter is illustrated and explained in more detail in the following paragraphs.

For 2 post assemblies, Figure 2 shows the horizontal spacing of posts to be used for proper support and appearance. The distance from the outside edge of the sign to the center of each post should be 20 % or 1/5 of the sign width. The distance between the posts should be 60 % or 3/5 of the sign width.

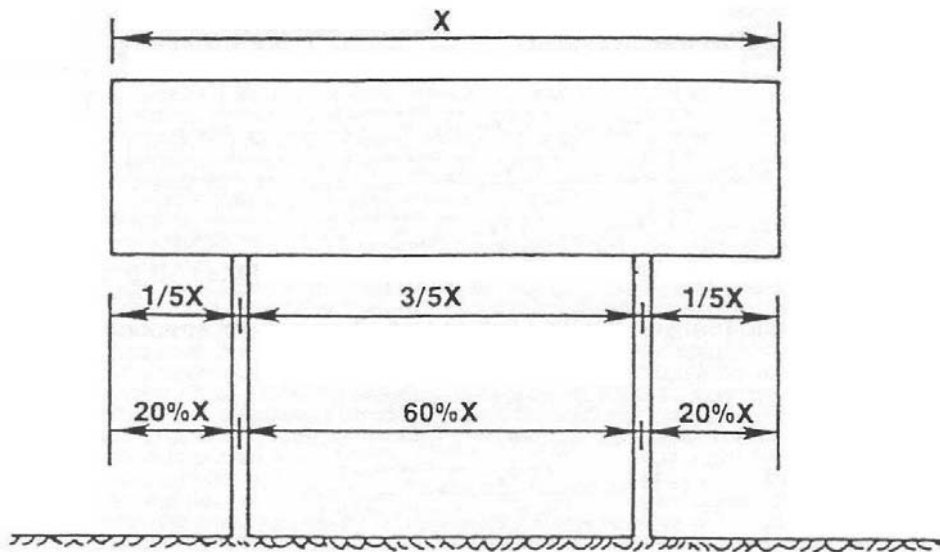

TYPICAL 2 POST ASSEMBLY

Figure 2

For 3 post assemblies, Figure 3 shows the horizontal spacing of posts to be used for proper support, appearance and safety. The distance from the outside edge of the sign to the center of each exterior post should be 16 2/3 % or 1/6 of the sign width. The distance between posts should be 33 1/3 % or 1/3 of the sign width. For safety reasons, the distance between the centers of the exterior posts on a 3-post assembly should not be less than 8 feet. In other words, there should not be more than 2 posts installed in an 8-foot path. This requirement limits the minimum width of sign for a 3-post assembly to 12 feet.

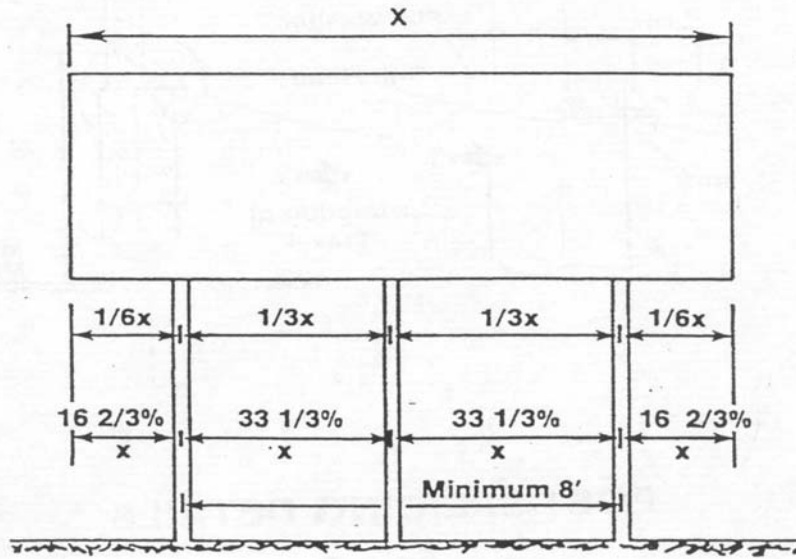

TYPICAL 3 POST ASSEMBLY

Figure 3.

Posts for smaller signs with less than 10 sq. ft. of area should be installed with approximately 4 feet below the ground surface. For larger signs and longer post lengths, the portion below the ground surface should be a minimum of 5 feet. Postholes should be backfilled with suitable soil tamped in place. In cases where the soil is unsuitable, crushed rock or crushed concrete should be used. Care should be taken in the process to see that the posts are plumb, insofar as possible, at all times. If properly placed, posts should remain firmly in position without needing further attention.

Figure 4 shows details for splicing signposts.

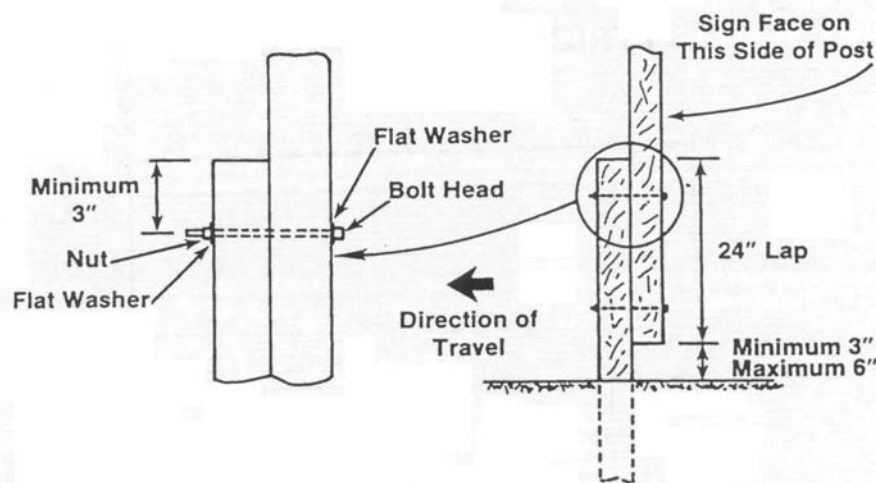

POST SPLICING DETAILS

Figure 4

Post splices should be made just above the ground surface to allow the breakaway features to function properly. No part of the splice is to be placed below the ground surface. The

splice is to be made in the direction of traffic with the upper post on the front and the lower post on the back. The distance from the bottom of the splice to the ground should be not less than 3” or more than 6”. The overlap should be 24” using at least two bolts to fasten the posts together. Flat washers are to be placed at both ends of the bolt.

Angle bracing on the backside of a sign may be used as an interim solution in unusual circumstances where wind load, soil condition and post length will not hold a normal installation in place. Post material no larger than 4” x 4” should be used for the brace. The supplemental post at the bottom of the brace should be placed 12-15 feet from the sign and should not project more than 12” above the ground surface. The top end of the brace should be fastened to the sign post at least 7 feet above the ground surface at the sign. Bracing should be used only where absolutely necessary. For large signs requiring braces for stability, a permanent more suitable solution such as steel breakaway sign supports installed by contract should be used. Interim bracing should be reviewed and approved by the state traffic engineer prior to use.

Breakaway Standards for 4 x 6 Wood Posts

Based on crash tests all new 4” x 6” wood posts shall be modified to meet breakaway standards by drilling two holes near the bottom portion of the post. This modification is not retroactive. See Figure 5, Typical Modification for Wood 4” x 6” Sign Posts, for details.

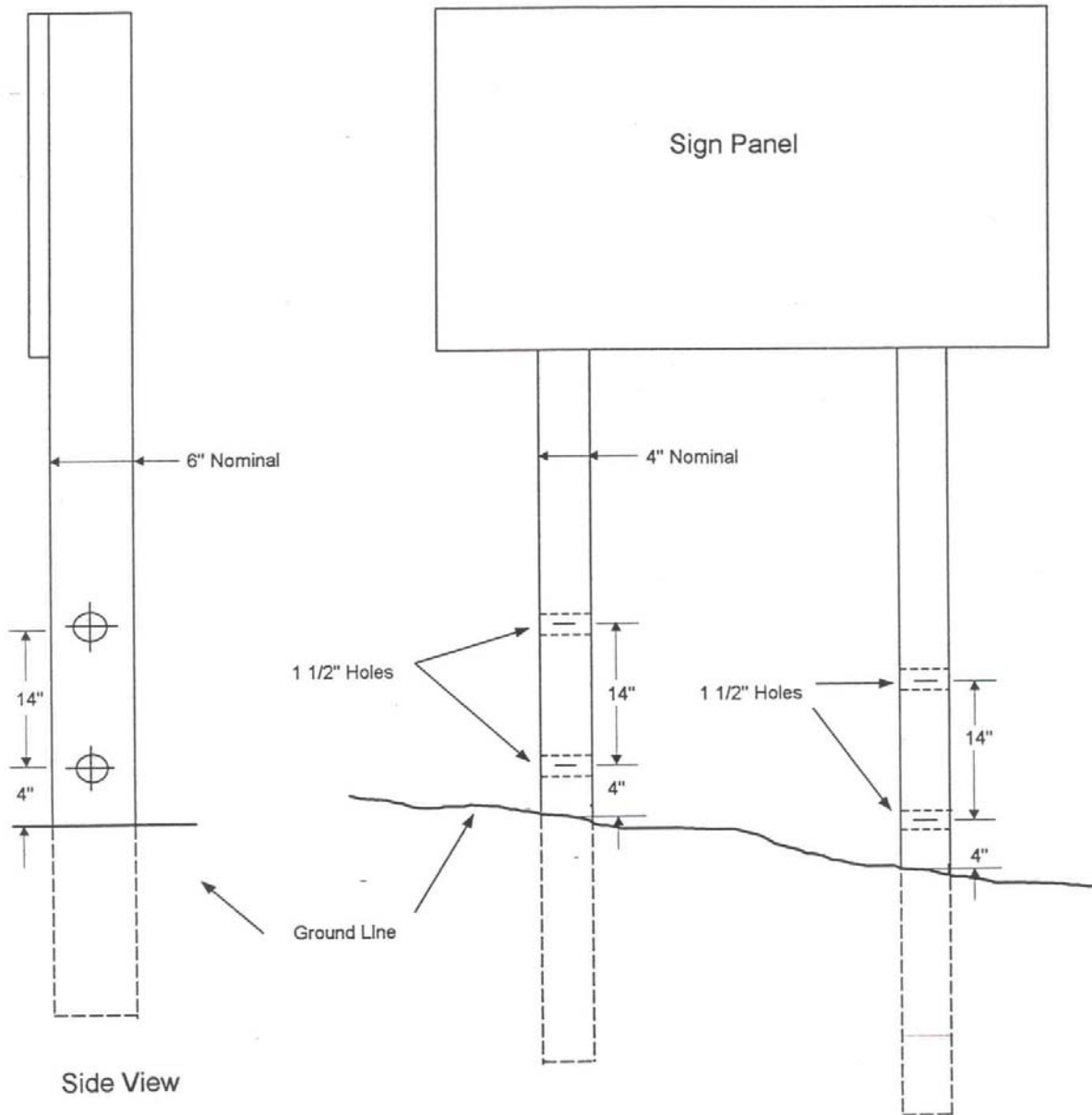

All 4"x6" wood posts shall be modified by having two 1-1/2" diameter holes drilled perpendicular to the roadway centerline.

Front View

Typical Modification for Wood 4"x6" Sign Posts

Figure 5

Multiple Posts

For those signs being supported by three or more posts, any two adjacent posts cannot be closer than 4 feet, center-to-center. If they are closer, the posts will not break as intended. These spacing requirements also apply to individual signs on separate posts mounted side by side such as multiple route shields.

Square Tubular Steel Posts

Square tube steel posts are available for use where the added original expense is justified. They shall be installed in compliance with current manufacturer's recommendations. An example of one of the manufacturer's post sizing charts is shown in Table 1. Additional charts are available from the manufacturer. Not all of the post sizes shown in Table 1 are available through the Department's warehouse. It may be necessary to purchase non-stocked sizes directly from the manufacturer. If any splices are to be used, they should be located at least 3 feet above the ground. Alternative methods may be used as approved by the Office of Traffic and Safety.

SINGLE POSTS WIND SPEED 80 MPH

12 GA. PERFORATED SQUARE POSTS
POSTS STRESSED UP TO 60,000 PSI (MIN. YIELD)

SIGN SIZE (INCHES)		HEIGHT TO BOTTOM OF SIGN (FEET)						
WIDTH	HEIGHT	5	6	7	8	9	10	
12	X 12	1 1/2	1 1/2	1 1/2	1 1/2	1 1/2	1 1/2	
12	X 18	1 1/2	1 1/2	1 1/2	1 1/2	1 1/2	1 1/2	
12	X 24	1 1/2	1 1/2	1 1/2	1 1/2	1 1/2	1 3/4	
12	X 30	1 1/2	1 1/2	1 1/2	1 1/2	1 3/4	1 3/4	
12	X 36	1 1/2	1 1/2	1 3/4	1 3/4	1 3/4	2	
12	X 48	1 3/4	1 3/4	1 3/4	2	2	2	
18	X 12	1 1/2	1 1/2	1 1/2	1 1/2	1 1/2	1 1/2	
18	X 18	1 1/2	1 1/2	1 1/2	1 1/2	1 1/2	1 3/4	
18	X 24	1 1/2	1 1/2	1 1/2	1 3/4	1 3/4	1 3/4	
18	X 30	1 1/2	1 1/2	1 3/4	1 3/4	2	2	
18	X 36	1 3/4	1 3/4	1 3/4	2	2	2	
18	X 48	1 3/4	2	2	2 1/4	2 1/4	2 1/4	
24	X 12	1 1/2	1 1/2	1 1/2	1 1/2	1 1/2	1 3/4	
24	X 18	1 1/2	1 1/2	1 1/2	1 3/4	1 3/4	1 3/4	
24	X 24	1 1/2	1 1/2	1 3/4	1 3/4	2	2	
24	X 30	1 3/4	1 3/4	1 3/4	2	2	2 1/4	
24	X 36	1 3/4	2	2	2	2 1/4	2 1/4	
24	X 48	2	2 1/4	2 1/4	2 1/2	2 1/2	2 1/2	
30	X 12	1 1/2	1 1/2	1 1/2	1 1/2	1 3/4	1 3/4	
30	X 18	1 1/2	1 1/2	1 3/4	1 3/4	1 3/4	2	
30	X 24	1 1/2	1 3/4	1 3/4	2	2	2	
30	X 30	1 3/4	1 3/4	2	2	2 1/4	2 1/4	
30	X 36	2	2	2 1/4	2 1/4	2 1/4	2 1/2	
30	X 48	2 1/4	2 1/4	2 1/2	2 1/2	A	A	
36	X 12	1 1/2	1 1/2	1 1/2	1 3/4	1 3/4	1 3/4	
36	X 18	1 1/2	1 3/4	1 3/4	1 3/4	2	2	
36	X 24	1 3/4	1 3/4	2	2	2 1/4	2 1/4	
36	X 30	1 3/4	2	2	2 1/4	2 1/4	2 1/2	
36	X 36	2	2 1/4	2 1/4	2 1/4	2 1/2	2 1/2	
36	X 48	2 1/4	2 1/2	2 1/2	A	B	C	
42	X 12	1 1/2	1 1/2	1 1/2	1 3/4	1 3/4	2	
42	X 18	1 3/4	1 3/4	1 3/4	2	2	2 1/4	
42	X 24	1 3/4	2	2	2 1/4	2 1/4	2 1/2	
42	X 30	2	2	2 1/4	2 1/4	2 1/2	2 1/2	
42	X 36	2 1/4	2 1/4	2 1/2	2 1/2	A	A	
42	X 48	2 1/2	2 1/2	A	B	C	C	
48	X 12	1 1/2	1 1/2	1 3/4	1 3/4	1 3/4	2	
48	X 18	1 3/4	1 3/4	2	2	2 1/4	2 1/4	
48	X 24	2	2	2 1/4	2 1/4	2 1/2	2 1/2	
48	X 30	2	2 1/4	2 1/4	2 1/2	2 1/2	A	
48	X 36	2 1/4	2 1/2	2 1/2	A	A	B	
48	X 48	2 1/2	A	B	C	C	C	

NOTE: ALL POSTS ARE 12 GA. EXCEPT AS NOTED BELOW
A - 2 1/2 SQ. TUBE 10 GA. PERFORATED
B - COMBINE 2 AND 2 1/4 TUBES 12 GA. WITH SLIP BASE
C - COMBINE 2 1/4 AND 2 1/2 TUBES 12 GA. WITH SLIP BASE
D - COMBINE 2 3/16 AND 2 1/2 TUBES 10 GA. WITH SLIP BASE
DESIGN CRITERIA: MAXIMUM STRESS = 60000 PSI

Use the standard size from the chart if it is stocked standard size. Otherwise use the next larger stocked standard size.

For other sizes and wind load ratings including double and triple post sizes, contact Tim Sothmann
Republic Companies at : 800-397-6204

Table 1: Square Tubular Steel Posts Sizing Chart

Document Revision History: 12-17-01
